

PENTAX[®]

**AUTO BELLOWS-A
SLIDE COPIER-A**

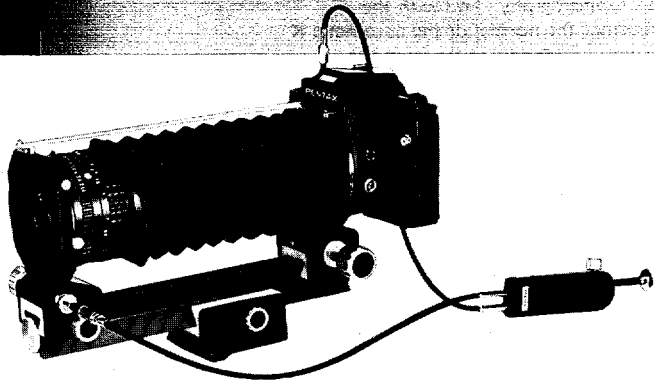

The Pentax Auto Bellows A used with a Pentax Bayonet Mount camera and any of the SMC Pentax lenses is all you need to be ready for a wide range of photography from close-up work to macrophotography. And with the addition of either the normal or the automatic K extension rings, a complete range from the closest of close-up work with all lenses right up to macrophotography is possible. The lenses can also be attached to the front plate in reverse, so there is no need for the reverse adaptor K-52mm or K-49mm. It is also equipped with diaphragm automation by the double cable release.

Moreover, together with the Slide Copier A, you can also reproduce slides and film strips.

Note: When you use a Pentax A lens, set the aperture ring at each f-number and do not set it at the "A" (Auto) position.

SPECIFICATIONS

| | |
|--|---|
| Suitable Cameras | Pentax 35mm bayonet-mount cameras |
| Suitable Lenses | SMC Pentax, SMC Pentax-M and SMC Pentax-A lenses. |
| Bellows Extension (Distance from the lens mount to the body mount) | NORMAL 38 ~ 170mm. (Lenses mounted in the normal way) REVERSE 56 ~ 174mm. (For 50mm f/1.7 lenses mounted in the reverse direction) |
| Automatic Diaphragm | Automatic diaphragm closed by double cable release. |
| Size | Width 97 x height 131 x length 207mm (Auto Bellows only) With 158 x height 135 x length 298mm (With Slide Copier) |
| Weight | 792g. (Auto Bellows only. Scales and double cable release included) 256g. (Slide Copier only) |
| Accessories | Double cable release, scale |

DESCRIPTION OF PARTS

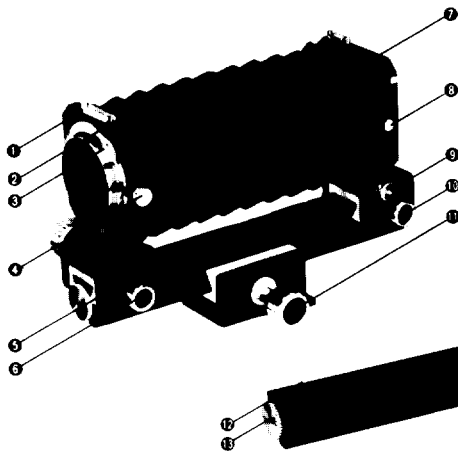

Auto Bellows A

- ① Rear Standard
- ② Bellows
- ③ Bellows-to-Camera Mounting Ring
- ④ Clamp Screw
- ⑤ Rack
- ⑥ Rear Standard Clamp Knob
- ⑦ Front Standard
- ⑧ Bellows Clamp Screw
- ⑨ Cable Release Socket
- ⑩ Front Standard Clamp Screw
- ⑪ Tripod Block Shift Knob
- ⑫ Red Dot
- ⑬ Stop Screw
- ⑭ Scale Mounts
- ⑮ Lens Lock Release Button
- ⑯ Bellows-to-Lens Mount
- ⑰ Front Standard Extension Knob
- ⑱ Rear Standard Extension Knob
- ⑲ Tripod Block Clamp Knob
- ⑳ Tripod Block

- ① Panel
- ② Slide Insertion Slot
- ③ Retainer Plate
- ④ Knob
- ⑤ Spring Clamp
- ⑥ Slide Holder
- ⑦ Multiplication Calibration
- ⑧ Slide Copier Rail
- ⑨ Strip Film Holder
- ⑩ Slide Copier Clamp Screw
- ⑪ Slide Copier Attachment Screw

SLide Copier A

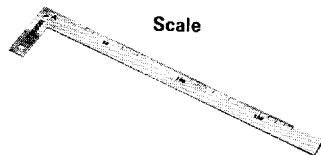
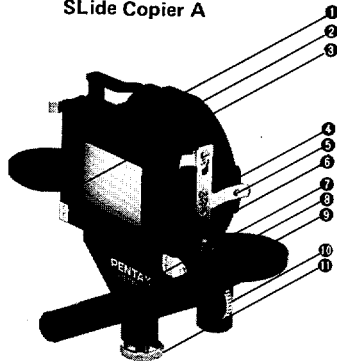

Double Cable Release A



HOW TO OPERATE THE AUTO BELLOWS A UNIT

With the Lens Normally Mounted

1. Loosen the clamp screw on the right side of the rear standard and remove the bellows-to-camera mounting ring.

2. Remove the lens from the Pentax camera and attach the bellows-to-camera mounting ring to the lens mount of the camera in place of the lens.

3. Now connect the camera to the bellows unit by attaching the bellows-to-camera mounting ring to the rear standard of the bellows. If the camera is to be used in the horizontal position, align the upper edge of the rear standard with the front edge of the pentaprism housing of the camera, and tighten the clamp screw.

1

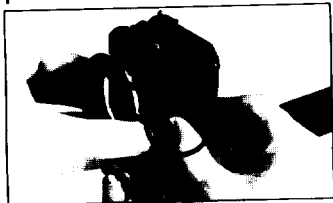

2



3

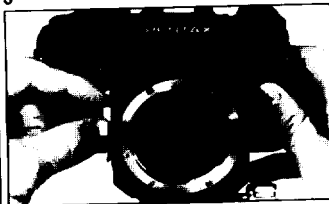

4. If the camera is to be used in the vertical position, rotate the camera so that the shutter release button is facing downward. Align the side edge of the camera with the upper edge of the rear standard and then tighten the clamp screw.

4

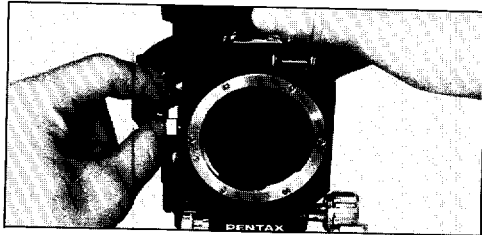

5. Attach the lens to the bellows-to-lens mounting ring located on the front standard. To remove the lens again, depress the lens lock button, and turn the lens 65° counterclockwise. Note that this lock button does not operate in the same way as the lens lock release lever on the camera.

5

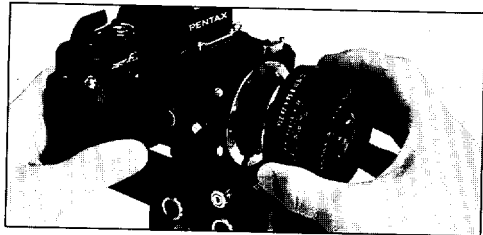

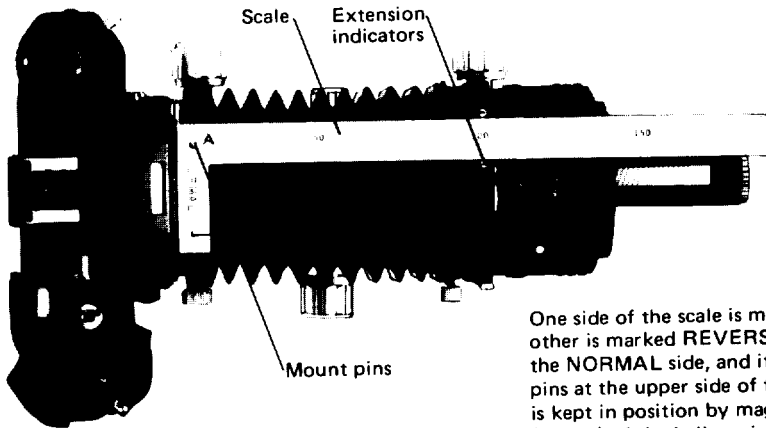

One side of the scale is marked **NORMAL**, while the other is marked **REVERSE**. The scale above shows the **NORMAL** side, and it is mounted on the two pins at the upper side of the rear standard. The scale is kept in position by magnets. The extension (length) of the bellows is indicated on the top of the front standard.

Loosen the front standard clamp screw and turn the front standard extension knob to adjust the extension of the bellows. After focusing, always remember to retighten the clamp screw.

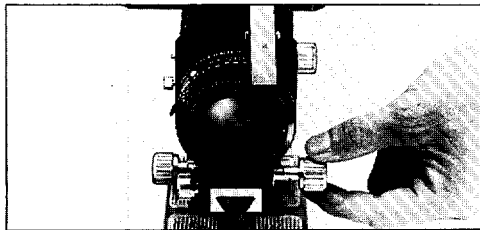

The bellows can also be adjusted by loosening the rear standard clamp screw and turning the rear standard extension knob. Be sure to retighten the clamp screw after focusing.

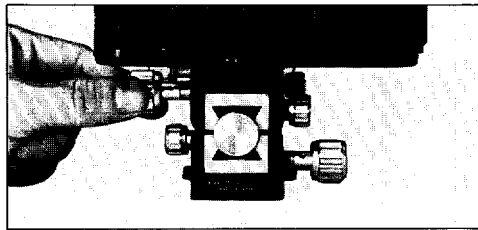

The tripod block can be freely moved back and forth the monorail by turning the tripod block shift knob after the tripod block clamp has been released, allowing free movement of the auto bellows assembly when mounted on a tripod. Be sure to retighten the clamp knob after adjustment.

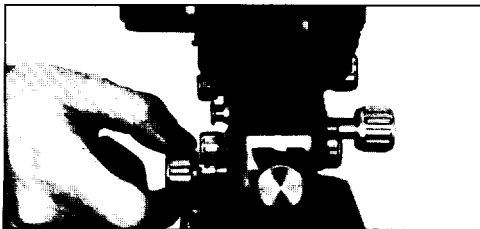

To attach the cable release, screw the unmarked end of the cable into the cable release socket on the camera and the end with the red ring into bellows cable release socket just below the front standard.



OPERATING THE BELLOWS UNIT

Cable Release Check

The double cable release is designed so that the lens stops down well before the shutter releases. With some cameras, however, adjustment may be required before the shutter will be released. Before you take pictures, check if the cable release adjustment is properly done. First, screw the cable with the red ringed tip into the cable release socket as described on page 10 and set the diaphragm of the lens to its smallest aperture. Check if the aperture diaphragm stops down to the smallest openings as you press the double cable release plunger. Secondly, screw the other cable into the camera shutter release button and press the plunger again to see if the lens aperture stops down fully before the shutter fires. If the shutter fires before the aperture stops down, adjust either the red ringed cable tip to extend

further or the shutter release cable tip to extend less.

In the case that the shutter does not fire, adjust cable tips reversely as described above.

It is advisable when you use the Super A, Super Program, Program A or Program Plus which has an electro-magnetic shutter release button, adjust the cable release tip to extend less.

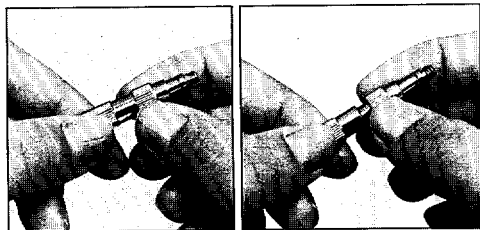

For T (time) exposures, set the shutter speed to B and depress the cable release plunger to open the shutter. To keep the shutter open for the duration of the exposure, tighten the lock screw at the side of the cable release. When the exposure time is up, close the shutter by loosening the lock screw.

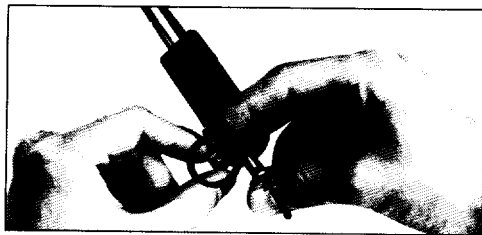

MOUNTING ON A TRIPOD

The auto bellows assembly should be mounted on a sturdy tripod at least 3.5kg. (7 lbs.) in weight and with very firm interlocking parts. The assembly should be positioned so that the majority of the weight leans slightly toward the lens side. While mounting the assembly at its center of gravity appears to be more stable, there is actually greater tendency toward camera "shake" with the assembly centered on the tripod. Best results are obtained if balance leans slightly on the lens side.

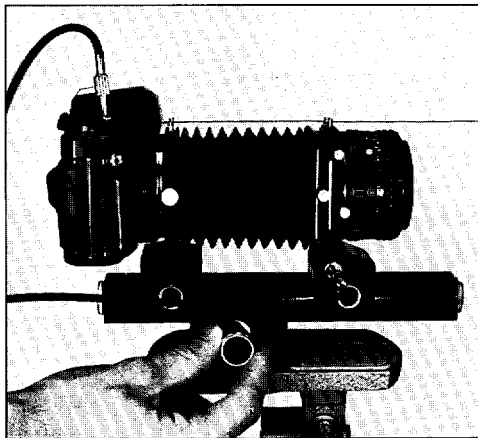

MOUNTING THE LENS IN REVERSE

Mount the lens in reverse only for magnifications greater than 1X.

1. Remove the stopper screw at the end of the monorail.
2. Loosen the bellows clamp screw and separate the bellows from the front standard.
3. Loosen the front standard clamp knob and remove the lens and front standard from the monorail.

1

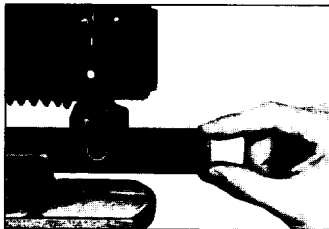

2



3



4. When using a 49mm filter size lens, reverse the front standard and then remove the adaptor by rotating it counterclockwise.
5. Screw the adaptor into the front frame of the lens.

6. Turn the lens and front frame in the reverse direction, and reinsert onto the monorail.

4

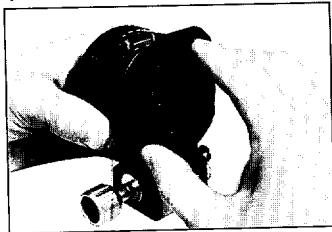

5

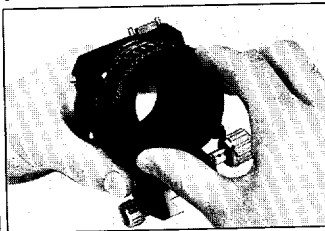

6



7. Attach the front of the bellows to the front frame of the lens, tighten the bellows clamp screw. 52mm threads are found inside the ring at the rear side of the front panel. This ring is used for attaching a 52 mm screw-in filter, 52mm lens hood, etc.

7

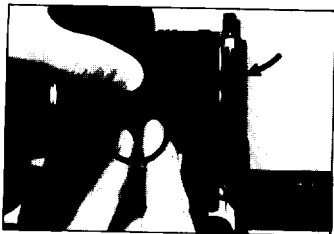

16

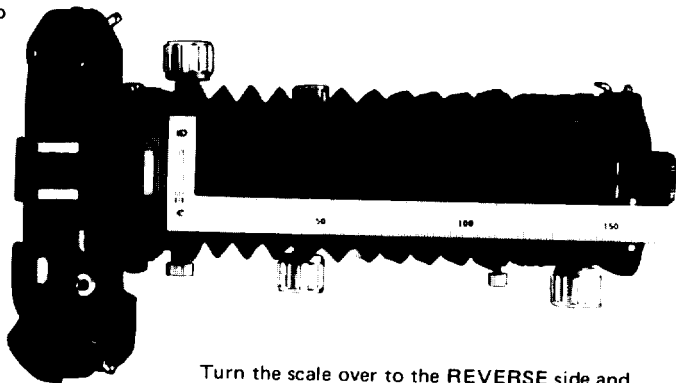

Turn the scale over to the **REVERSE** side and mount it over the rear and front standards as before.

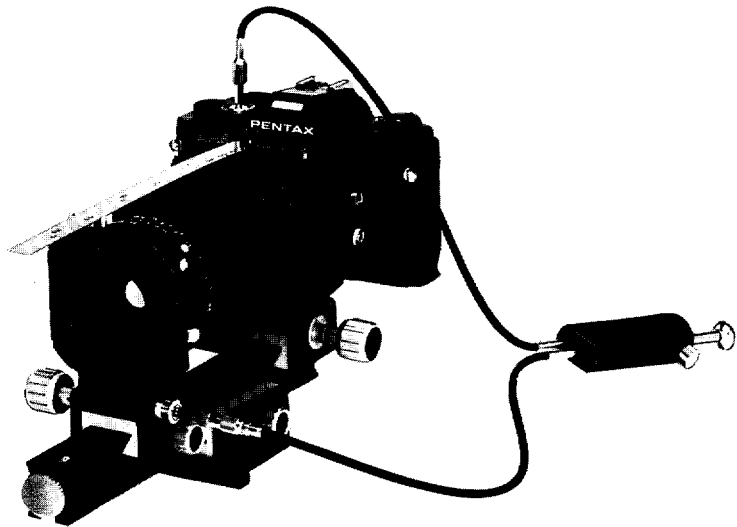



FOCUSING

The diaphragm remains open no matter what aperture is selected. So it is possible to focus in the same way as any ordinary Pentax camera. To focus the camera, move either the front standard or rear standard extension knobs or the shift knob, while looking through the viewfinder. What focusing method should be used depends on magnifications. The choice of the focusing methods depends on the photographing magnification. When the magnification is relatively low, adjust the front standard extension. As the magnification gets higher, it's best to use the rear standard and the tripod block shift movements.

If the image magnification is higher than you desired, shorten the bellows extension and if the magnification is lower than you expected, extend the bellows.

At higher magnifications, the cross microprism and split image become dark, making focusing difficult. In this case, use the surrounding matte for focusing.

Note: When photographing with bellows unit, keep the lens focusing ring at the infinity position. The



focusing ring does not work effectively in high magnification photography. Also, the depth-of-field scale on the lens barrel cannot be used for reference in the close-up and macro-photography. Check the depth-of-field directly through the finder stopping down the lens aperture.

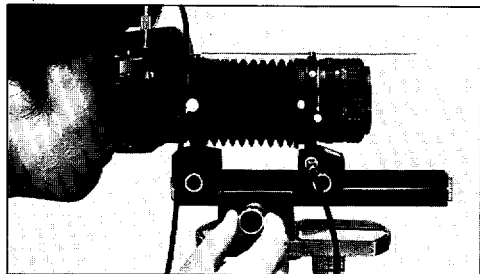

Depth-of-Field

The closer the lens is to the subject, the shallower the depth-of-field becomes. Even for minimum apertures of $f/22$ for standard lenses and $f/32$ for SMC Pentax Macro 50 and 100mm lenses, you may still not be able to get the desired depth-of-field. Therefore, be very careful in your focusing. For close-ups, the focus plane lies right in the center of the depth-of-field. So the best focusing of the area between the closest and farthest limits of the depth-of-field is achieved by focusing for a position exactly mid-way between the two planes.

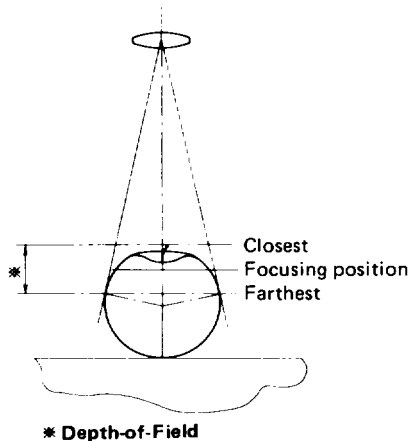

EXPOSURE

Exposure

The automatic diaphragm of the lens is operated by the double cable release when the auto bellows is used. Although it is convenient to leave the diaphragm opened for focusing, exposure reading must be made with the diaphragm stopped down to shooting aperture. Exposures can still be made on automatic with cameras featuring automatic exposure, but the diaphragm must be stopped down for exposure readings. To close the diaphragm, first set the desired aperture on the lens, then push in either of the knurled rings shown in the illustration and rotate clockwise. After setting the camera for the proper exposure, make the exposure by pressing the plunger of the double cable release. To reopen the diaphragm, turn the knurled ring counterclockwise. **CAUTION:** When making

exposures with cameras other than the Pentax LX, cover the viewfinder eyepiece to prevent stray light from adversely affecting the exposure.

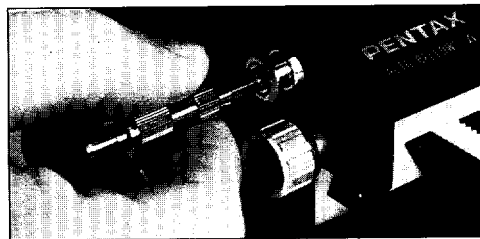

Outside the Exposure Meter Range

When the subject is too dark and the exposure lies outside the metering range at the particular aperture you wish to use, first open the diaphragm until a reading can be made. For example, if you want to use $f/11$, but the best possible reading is $f/4$ at $1/2$ sec., change the shutter speed by the same number of stops as the diaphragm is closed down to the desired aperture. That is, $f/4$ to $f/11$ is 3 stops, so change the speed by 3 stops also — from $1/2$ sec. to 4 sec.

| | | | | | | | | | | |
|---------------------|------|-----|-----|-----|-----|---|----|----|----|----|
| F | 1.4 | 2 | 2.8 | 4 | 5.6 | 8 | 11 | 16 | 22 | 32 |
| Exposure Time (sec) | 1/15 | 1/8 | 1/4 | 1/2 | 1 | 2 | 4 | 8 | 16 | 32 |

Reciprocity Failure of Color Films

For long exposures of over 1 sec. and especially over 10 sec. with a color film, reciprocity failure will cause an under exposure. Therefore, the exposure time must be compensated. Also, with most color reversal films, the same phenomenon causes a color shift in color reproduction if the exposure time exceeds $1/10$ sec.

Such a color shift can be compensated by using CC filters (Color Compensation filters). Refer to the Kodak Color Data Guide or instruction of each film.

Larger Than Life Size

When the lens-to-film distance of any lens is twice the focal length of the lens, as shown in Fig. 2 on the next page, the photographic magnification will be 1X (life size). The bellows of the Auto Bellows A unit can be extended from 38mm to 170mm (the distance from the bellows-to-lens mount to the plane where the bellows-to-camera mounting ring meets the lens mount of the camera). So any lens of focal length under 150mm can be used to photograph larger than life.

Figs. 1 to 3 refer to the Macro 50mm lens. The lens has been designed for focusing with "a" larger than "b" which is the case for ordinary photography as in Fig. 1. So it is only natural that optimum sharpness when photographing larger than life size, as in Fig. 3, is achieved with the lens reversed. The close-up tables between pages 33 and 51 have been

roughly divided into those for up to life size (pp. 33 ~ 41) and those for larger than life (pp. 43 ~ 51).

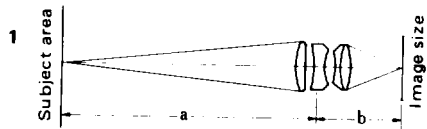

Apertures Are Not Visible in the Viewfinder
Even though your camera may feature viewfinder aperture readout, apertures are not displayed when the auto bellows unit is used as the lens is separated from the camera.

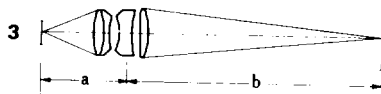
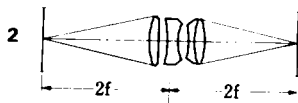

Using the Screw-Mount Takumar Lenses

Takumar screw-mount lenses can be attached to the Auto Bellows A unit with the aid of the mount adaptor K.

First screw the mount adaptor into the rear of the Takumar screw-mount lens. Line up the red dot on the adaptor with the red dot on the bellows-to-lens mount. Insert the lens and rotate it clockwise 65° to lock it into position.

The lens and mount adaptor are removed from the bellows unit in the same way as with the Pentax Bayonet Mount cameras.

Focusing and exposure measurements are also the same as for ordinary cameras.

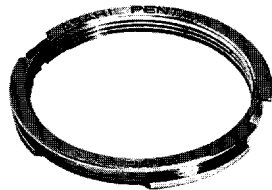

HOW TO USE THE CLOSE-UP TABLES

1. Area to be photographed
2. Lens
3. Picture area of film

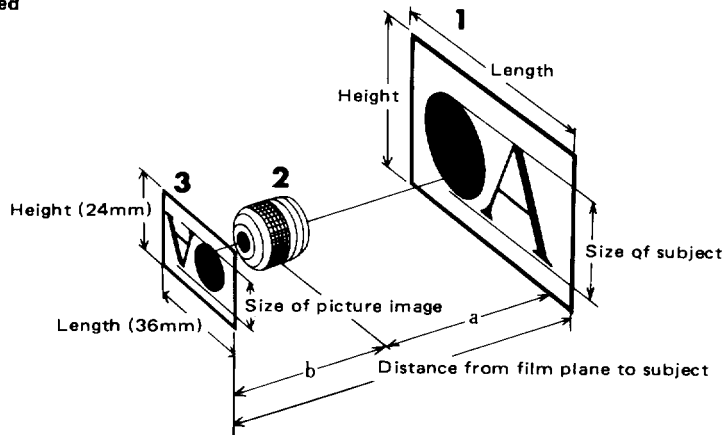

Magnification

$$\text{Magnification} = \frac{\text{Size of image}}{\text{Size of subject}} \text{ or}$$

$$\frac{\text{Height/length of picture area}}{\text{Height/length of subject}}$$

The size of the picture area for Pentax Bayonet Mount cameras is 24mm x 36mm. Therefore, magnification can be expressed as

$$\frac{24\text{mm}}{\text{Height of area to be photographed}} \text{ or}$$

$$\frac{36\text{mm}}{\text{Length of area to be photographed}}$$

Area to be Photographed

Is the subject area (measured as height x length) which completely fills the picture area on the film.

Exposure Factors

The Pentax Bayonet Mount cameras have a built-in through-the-lens exposure meter which measures the amount of light actually passing through the lens. Therefore, these exposure factors will not be required. But bear in mind that close-up work requires longer exposure times than when photographing subjects of the same brightness at normal distances.

How to Read the Close-Up Tables

These tables may be used in three different ways, depending on whether you start with the magnification, picture area, or the film-to-subject distance.

When Starting with Magnification

When you want to photograph a subject of a certain size so that the image will be a particular size on the film, start by determining the magnification.

For example, if you want to take a photograph of a subject 40mm in size so that its size on the film will be 32mm, when using a 50mm f/1.7 lens, the magnification will be $32/40 = 0.8$. Table 1 shows that the bellows in this case should be extended to somewhere in between 40 and 50mm. To find the exact extension, use the simple mathematical formula given here. On page 26 for example, "a" is the distance between the subject and the first nodal point in the lens (the point where light enters the lens and crosses the principal axis), "b" is the distance from the second nodal point (the point at which light crossing the axis leaves the lens) to the film plane, "f" is the

actual focal length of the lens.

To determine "a", the formula is

m (magnification) = $\frac{f}{a - b}$ and to determine

"b" the formula is $b = ma$. Then, $b - f$ (found in mf) is the exact distance of the lens extension. Measure this distance with the scales (shown on page 8 and on page 16) when adjusting the position of the front standard. Focus by turning the tripod positions shift knob as shown on page 19. Be careful not to touch the rear standard extension knob, since this may alter the bellows extension and the magnification. Depending on the lens, the real focal length "f" may differ slightly from the nominal focal length. See your local Pentax dealer or Service Center for further details.

When Starting With Picture Area

When you want to photograph a particular subject area, first measure the size of the area. For example, if you want a subject measuring 30 x 45mm to completely fill the picture area of the film when using a 50mm f/1.7 lens, Table 1 shows that the bellows extension will have to be about 40 to 50mm. Again, use the scales to adjust the bellows extension, and the tripod block shift knob for the focusing. If small changes in the size of the area to be photographed are permissible, focusing may also be achieved by shifting the camera and tripod back and forth a little, or the subject itself may be moved. Even adjustments to the rear standard (by turning the rear standard extension knob) are possible.

Remember that ordinary focusing (with the Focusing Ring of the lens) is rarely adopted when using bellows units.

Film-to-Subject Distance

The Pentax Bayonet Mount cameras have no markings to show the exact position of the film plane, but the rear edge of the pentaprism housing indicated below is almost in the same plane as the film. The desired distance is first determined from the close-up tables, and then the scales are used to measure the distance between the subject and the rear edge of the pentaprism more precisely.

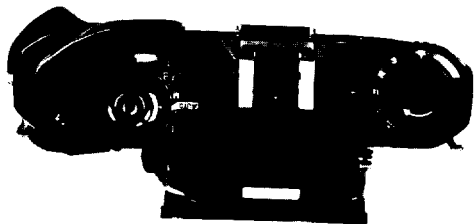

30

Image Quality and Aperture

As the image magnification approaches to the life size, generally optical aberrations tend to increase to deteriorate the picture quality. This tendency becomes more significant when you use shorter focal length lenses or telephoto lenses in short lens barrels for close-up photography at around 1X magnification.

If you reverse the lens for more than the life size imaging, the similar tendency occurs around 1X magnification and it is less in greater magnification. Also, fast lenses are not suitable for close-up photography by the same reason as mentioned above.

Lenses not included in the tables have been omitted because they are not suitable for close-up works with the Auto Bellows A unit. The 50mm f/1.2 and 50mm f/1.4 lenses are most suitable for photographing three dimensional subjects where

sharp images in all four corners are not necessary. Although it is said that the image quality isn't so good when you stop down a lens more than $f/11$ due to the diffraction phenomenon which is inherent to the optical imaging, it is rather recommended to stop down the lens to $f/11$ or further in the close-up photography around life size magnification. Because, the increases optical aberrations in close-up shootings, at around 1X magnification regardless of the lens in normal or reverse position, exceed the effect of the optical diffraction mentioned above. You'd better to use small apertures when you apply a fast lens such as 50mm $f/1.4$ or the 50mm $f/1.2$.

The close-up tables 1, 2, 7, 8, 16, 17 and 18 (for standard lenses) list the apertures recommended to reproduce sharp images of the flat subject plane over the entire picture format.

Lenses Best for Close-Ups

The SMC Pentax Macro 50mm and 100mm lenses are designed for maximum performance at magnifications of $1/5 \sim 1/10X$. Hence they are particularly suitable for close-up work requiring critical focusing. Distortion (a kind of aberration where straight lines do not come out as straight lines in the photograph) has been reduced to a minimum. So the macro lenses are very good for close-up work requiring highly accurate dimensions.

CLOSE-UP TABLES (use of Lenses in Normal Position)

SPECIAL NOTES

1. The wide-angle lenses up to 35mm and the 40mm f/2.8 lens are excluded from the close-up tables. For such wide-angle lenses with short focal lengths and high-speed lenses are not suited for close-up work of high magnification, unless they are used in reverse.

The extension of the Auto Bellows A is 38mm or more. Therefore, if a wide-angle lens, 35mm or less, is used with the bellows, the magnification exceeds 1X. The lens should be reversed at such a time.

The 40mm f/2.8 lens, which provides a magnification of about 1X, should be used with the Auto Extension Tube K for close-up work.

2. Also excluded from the close-up tables are fast lenses such as the 50mm f/1.2 and 50mm f/1.4, which provide a magnification of about 1X and have unsatisfactory sharpness for flat subjects.

3. Magnification for the normal position has only been listed up to a little over 1X. For greater magnification, use the lens in reverse.

4. The SMC Pentax Macro 50mm lens can attain magnification of 1X by employing the Auto Extension Tube K No. 3, while the Macro 100mm attains magnification of over 1X with the Auto Extension Tube K50. Diaphragm automation and full-aperture metering are also retained. The use of the extension tubes is highly recommended.

Table 1: M-50mm f/1.7 and A-50mm f/1.7 (Normal)(Distance scale set to ∞)

| Magnification | Bellows Extension | Working Distance | Photographing Area | Film-to-Object Distance | Exposure Factor |
|----------------------|--------------------------|-------------------------|---------------------------|--------------------------------|------------------------|
| 0.8 | 42 | 93 | 45 x 30 | 207 | 3.0 |
| 0.9 | 47 | 86 | 40 x 27 | 205 | 3.3 |
| 1.0 | 52 | 80 | 36 x 24 | 204 | 3.7 |

Table 2: M-50mm f/2 (Normal)(Distance scale set to ∞)

| Magnification | Bellows Extension | Working Distance | Photographing Area | Film-to-Object Distance | Exposure Factor |
|----------------------|--------------------------|-------------------------|---------------------------|--------------------------------|------------------------|
| 0.8 | 42 | 98 | 45 x 30 | 207 | 3.2 |
| 0.9 | 47 | 90 | 40 x 27 | 205 | 3.6 |
| 1.0 | 52 | 85 | 36 x 24 | 204 | 3.9 |

Table 3: A-Macro 50mm f/2.8 (Normal)(Distance scale set to ∞)

| Magnification | Bellows Extension | Working Distance | Photographing Area | Film-to-Object Distance | Exposure Factor |
|----------------------|--------------------------|-------------------------|---------------------------|--------------------------------|------------------------|
| 0.8 | 42 | 98 | 45 x 30 | 210 | 2.9 |
| 0.9 | 47 | 91 | 40 x 27 | 208 | 3.2 |
| 1.0 | 52 | 85 | 36 x 24 | 208 | 3.5 |

Table 4: M-Macro 50mm f/4 (Normal)(Distance scale set to ∞)

| Magnification | Bellows Extension | Working Distance | Photographing Area | Film-to-Object Distance | Exposure Factor |
|----------------------|--------------------------|-------------------------|---------------------------|--------------------------------|------------------------|
| 0.8 | 41 | 109 | 45 x 30 | 210 | 3.5 |
| 0.9 | 46 | 102 | 40 x 27 | 208 | 3.9 |
| 1.0 | 52 | 96 | 36 x 24 | 208 | 4.3 |

Table 5: M-Macro 100mm f/4 (Normal)(Distance scale set to ∞)

| Magnification | Bellows Extension | Working Distance | Photographic Area | Film-to-Object Distance | Exposure Factor |
|----------------------|--------------------------|-------------------------|--------------------------|--------------------------------|------------------------|
| 0.4 | 40 | 340 | 90 x 60 | 491 | 2.1 |
| 0.5 | 50 | 290 | 72 x 48 | 451 | 2.5 |
| 0.6 | 60 | 256 | 60 x 40 | 428 | 2.8 |
| 0.7 | 70 | 233 | 51 x 34 | 414 | 3.2 |
| 0.8 | 80 | 215 | 45 x 30 | 406 | 3.6 |
| 0.9 | 90 | 201 | 40 x 27 | 402 | 4.1 |
| 1.0 | 100 | 190 | 36 x 24 | 401 | 4.6 |

Table 6: Bellows 100mm f/4 (Normal)(Distance scale set to ∞)

| Magnification | Bellows Extension | Working Distance | Photographing Area | Film-to-Object Distance | Exposure Factor |
|----------------------|--------------------------|-------------------------|---------------------------|--------------------------------|------------------------|
| 0.1 | 48 | 1088 | 360 x 240 | 1210 | 1.2 |
| 0.2 | 58 | 589 | 180 x 120 | 720 | 1.5 |
| 0.3 | 68 | 423 | 120 x 80 | 564 | 1.8 |
| 0.4 | 78 | 340 | 90 x 60 | 491 | 2.1 |
| 0.5 | 88 | 290 | 72 x 48 | 451 | 2.5 |
| 0.6 | 98 | 256 | 60 x 40 | 428 | 2.8 |
| 0.7 | 108 | 233 | 51 x 34 | 414 | 3.2 |
| 0.8 | 118 | 215 | 45 x 30 | 406 | 3.6 |
| 0.9 | 128 | 201 | 40 x 27 | 402 | 4.1 |
| 1.0 | 138 | 190 | 36 x 24 | 401 | 4.6 |



USE OF LENSES IN REVERSE POSITION

1. For producing high magnification images more than life size as described on page 23, the lens must be mounted in reverse position with Auto Bellows A. This type of close-up work is most effective with retrofocus wide-angle lenses. When reversed, automatic diaphragm action is retained and the highest magnifications range from 6.2X ~ 6.6X with 28mm lenses, 6.1X with the 30mm lens and 5X ~ 5.2X with the 35mm lenses. Fast f/2 wide-angle lenses are not suited for bellows photography with the lens reversed.
2. Telephoto lenses are also not suited for reversed lens photography.
3. It is pointless to reverse the Macro 100mm lens and other lenses with a longer focal length as magnification will not exceed 1X, even with the maximum bellows extension.
4. In macrophotography with the lens reversed, exposure factor increases exceedingly, causing the exposure times to be extremely long. Therefore, you have to keep in mind that the exposure must be compensated for the reciprocity failure of color films as described on page 22.
5. When shooting highly magnified subjects on a level surface, greater framing precision will be obtained if the Macrophoto Stand is used.
6. At high magnifications, the effective f-number also becomes very large; consequently, sharpness of image drops off in proportion to the degree that the lens is stopped down.

Table 7: M-50mm f/1.7 and A-50mm f/1.7 (Lens Reversed)(Distance scale set to ∞)

| Magnification | Bellows Extension | Working Distance | Photographing Area | Film-to-Object Distance | Exposure Factor |
|----------------------|--------------------------|-------------------------|---------------------------|--------------------------------|------------------------|
| 1.0 | 61 | 90 | 24 x 36 | 204 | 3.7 |
| 1.2 | 72 | 82 | 20 x 30 | 206 | 4.5 |
| 1.4 | 82 | 76 | 17 x 26 | 210 | 5.4 |
| 1.6 | 92 | 71 | 15 x 23 | 216 | 6.3 |
| 1.8 | 103 | 67 | 13 x 20 | 223 | 7.4 |
| 2.0 | 113 | 64 | 12 x 18 | 230 | 8.5 |
| 2.2 | 124 | 62 | 11 x 16 | 238 | 9.7 |
| 2.4 | 134 | 60 | 10 x 15 | 247 | 11.0 |
| 2.6 | 144 | 58 | 9 x 14 | 255 | 12.4 |
| 2.8 | 155 | 57 | 9 x 13 | 264 | 13.8 |
| 3.0 | 165 | 56 | 8 x 12 | 274 | 15.4 |

Table 8: M-50mm f/2 (Lens Reversed)(Distance scale set to ∞)

| Magnification | Bellows Extension | Working Distance | Photographing Area | Film-to-Object Distance | Exposure Factor |
|----------------------|--------------------------|-------------------------|---------------------------|--------------------------------|------------------------|
| 1.0 | 61 | 91 | 24 x 36 | 204 | 3.9 |
| 1.2 | 72 | 83 | 20 x 30 | 206 | 4.8 |
| 1.4 | 82 | 76 | 17 x 26 | 210 | 5.7 |
| 1.6 | 93 | 72 | 15 x 23 | 216 | 6.7 |
| 1.8 | 103 | 68 | 13 x 20 | 223 | 7.8 |
| 2.0 | 113 | 65 | 12 x 18 | 230 | 8.9 |
| 2.2 | 124 | 63 | 11 x 16 | 238 | 10.2 |
| 2.4 | 134 | 61 | 10 x 15 | 247 | 11.5 |
| 2.6 | 145 | 59 | 9 x 14 | 256 | 12.9 |
| 2.8 | 155 | 58 | 9 x 13 | 265 | 14.3 |
| 3.0 | 165 | 57 | 8 x 12 | 274 | 15.9 |

Table 9: A-Macro 50mm f/2.8 (Lens Reversed)(Distance scale set to ∞)

| Magnification | Bellows Extension | Working Distance | Photographing Area | Film-to-Object Distance | Exposure Factor |
|----------------------|--------------------------|-------------------------|---------------------------|--------------------------------|------------------------|
| 1.2 | 75 | 82 | 20 x 30 | 209 | 4.3 |
| 1.4 | 86 | 75 | 17 x 26 | 214 | 5.2 |
| 1.6 | 96 | 71 | 15 x 23 | 219 | 6.2 |
| 1.8 | 106 | 67 | 13 x 20 | 226 | 7.2 |
| 2.0 | 117 | 64 | 12 x 18 | 234 | 8.3 |
| 2.2 | 127 | 62 | 11 x 16 | 242 | 9.5 |
| 2.4 | 138 | 60 | 10 x 15 | 250 | 10.8 |
| 2.6 | 148 | 58 | 9 x 14 | 259 | 12.1 |
| 2.8 | 158 | 57 | 9 x 13 | 268 | 13.6 |
| 3.0 | 169 | 56 | 8 x 12 | 277 | 15.1 |

Table 10: M-Macro 50mm f/4 (Lens Reversed)(Distance scale set to ∞)

| Magnification | Bellows Extension | Working Distance | Photographing Area | Film-to-Object Distance | Exposure Factor |
|----------------------|--------------------------|-------------------------|---------------------------|--------------------------------|------------------------|
| 1.2 | 75 | 86 | 20 x 30 | 209 | 5.2 |
| 1.4 | 86 | 80 | 17 x 26 | 213 | 6.1 |
| 1.6 | 96 | 75 | 15 x 23 | 219 | 7.1 |
| 1.8 | 106 | 72 | 13 x 20 | 226 | 8.3 |
| 2.0 | 117 | 69 | 12 x 18 | 233 | 9.4 |
| 2.2 | 127 | 67 | 11 x 16 | 241 | 10.7 |
| 2.4 | 137 | 65 | 10 x 15 | 250 | 12.1 |
| 2.6 | 148 | 63 | 9 x 14 | 258 | 13.5 |
| 2.8 | 158 | 62 | 9 x 13 | 267 | 15.0 |
| 3.0 | 168 | 60 | 8 x 12 | 276 | 16.6 |

Table 11: A-28mm f/2.8 (Lens Reversed)(Distance scale set to ∞)

| Magnification | Bellows Extension | Working Distance | Photographing Area | Film-to-Object Distance | Exposure Factor |
|---------------|-------------------|------------------|--------------------|-------------------------|-----------------|
| 2.6 | 63 | 48 | 9.2 x 13.8 | 165 | 9.6 |
| 3.0 | 74 | 46 | 8.0 x 12.0 | 175 | 12.2 |
| 3.3 | 83 | 46 | 7.3 x 10.9 | 183 | 14.4 |
| 3.6 | 92 | 45 | 6.7 x 10.0 | 191 | 16.8 |
| 4.0 | 103 | 44 | 6.0 x 9.0 | 201 | 20.2 |
| 4.3 | 112 | 44 | 5.6 x 8.4 | 210 | 23.0 |
| 4.6 | 121 | 43 | 5.2 x 7.8 | 218 | 26.0 |
| 5.0 | 132 | 43 | 4.8 x 7.2 | 229 | 30.2 |
| 5.3 | 141 | 42 | 4.5 x 6.8 | 237 | 33.6 |
| 5.6 | 149 | 42 | 4.3 x 6.4 | 245 | 37.2 |
| 6.0 | 161 | 42 | 4.0 x 6.0 | 257 | 42.2 |
| 6.3 | 169 | 41 | 3.8 x 5.7 | 265 | 46.2 |
| 6.6 | 178 | 41 | 3.6 x 5.5 | 273 | 50.4 |

Table 12: M-28mm f/2.8 (Lens Reversed)(Distance scale set to ∞)

| Magnification | Bellows Extension | Working Distance | Photographing Area | Film-to-Object Distance | Exposure Factor |
|----------------------|--------------------------|-------------------------|---------------------------|--------------------------------|------------------------|
| 2.6 | 56 | 48 | 9.2 x 13.8 | 158 | 10.1 |
| 3.0 | 67 | 46 | 8.0 x 12.0 | 167 | 12.8 |
| 3.3 | 75 | 45 | 7.3 x 10.9 | 175 | 15.1 |
| 3.6 | 84 | 45 | 6.7 x 10.0 | 183 | 17.5 |
| 4.0 | 95 | 44 | 6.0 x 9.0 | 193 | 21.0 |
| 4.3 | 104 | 43 | 5.6 x 8.4 | 202 | 23.8 |
| 4.6 | 112 | 43 | 5.2 x 7.8 | 210 | 26.9 |
| 5.0 | 124 | 42 | 4.8 x 7.2 | 220 | 31.2 |
| 5.3 | 132 | 42 | 4.5 x 6.8 | 229 | 34.6 |
| 5.6 | 141 | 42 | 4.3 x 6.4 | 237 | 38.2 |
| 6.0 | 152 | 41 | 4.0 x 6.0 | 248 | 43.3 |
| 6.3 | 161 | 41 | 3.8 x 5.7 | 256 | 47.4 |
| 6.6 | 169 | 41 | 3.6 x 5.5 | 265 | 51.6 |

Table 13: M-30mm f/2.8 (Lens Reversed)

| Magnification | Bellows Extension | Working Distance | Photographing Area | Film-to-Object Distance | Exposure Factor |
|---------------|-------------------|------------------|--------------------|-------------------------|-----------------|
| 2.6 | 64 | 49 | 9.2 x 13.8 | 166 | 10.0 |
| 3.0 | 76 | 48 | 8.0 x 12.0 | 177 | 12.7 |
| 3.3 | 85 | 47 | 7.3 x 10.9 | 185 | 14.9 |
| 3.6 | 94 | 46 | 6.7 x 10.0 | 193 | 17.4 |
| 4.0 | 106 | 45 | 6.0 x 9.0 | 205 | 20.9 |
| 4.3 | 115 | 45 | 5.6 x 8.4 | 213 | 23.7 |
| 4.6 | 124 | 44 | 5.2 x 7.8 | 222 | 26.7 |
| 5.0 | 136 | 44 | 4.8 x 7.2 | 233 | 31.0 |
| 5.3 | 145 | 43 | 4.5 x 6.8 | 242 | 34.4 |
| 5.6 | 155 | 43 | 4.3 x 6.4 | 251 | 38.0 |
| 6.0 | 167 | 43 | 4.0 x 6.0 | 263 | 43.1 |

(Distance scale set to ∞)

Table 14: A-35mm f/2.8 (Lens Reversed)(Distance scale set to ∞)

| Magnification | Bellows Extension | Working Distance | Photographing Area | Film-to-Object Distance | Exposure Factor |
|----------------------|--------------------------|-------------------------|---------------------------|--------------------------------|------------------------|
| 1.8 | 59 | 57 | 13.3 x 20.0 | 170 | 6.2 |
| 2.0 | 66 | 55 | 12.0 x 18.0 | 175 | 7.2 |
| 2.3 | 77 | 53 | 10.4 x 15.7 | 183 | 8.9 |
| 2.6 | 87 | 51 | 9.2 x 13.8 | 192 | 10.8 |
| 3.0 | 101 | 49 | 8.0 x 12.0 | 204 | 13.6 |
| 3.3 | 112 | 48 | 7.3 x 10.9 | 213 | 15.9 |
| 3.6 | 122 | 47 | 6.7 x 10.0 | 223 | 18.4 |
| 4.0 | 136 | 46 | 6.0 x 9.0 | 236 | 21.9 |
| 4.3 | 147 | 46 | 5.6 x 8.4 | 246 | 24.8 |
| 4.6 | 157 | 45 | 5.2 x 7.8 | 256 | 27.9 |
| 5.0 | 172 | 44 | 4.8 x 7.2 | 270 | 32.3 |

Table 15: M-35mm f/2.8 (Lens Reversed)(Distance scale set to ∞)

| Magnification | Bellows Extension | Working Distance | Photographing Area | Film-to-Object Distance | Exposure Factor |
|----------------------|--------------------------|-------------------------|---------------------------|--------------------------------|------------------------|
| 1.8 | 59 | 57 | 13.3 x 20.0 | 170 | 6.2 |
| 2.0 | 66 | 55 | 12.0 x 18.0 | 175 | 7.2 |
| 2.3 | 77 | 53 | 10.4 x 15.7 | 183 | 8.9 |
| 2.6 | 87 | 51 | 9.2 x 13.8 | 192 | 10.8 |
| 3.0 | 101 | 49 | 8.0 x 12.0 | 204 | 13.6 |
| 3.3 | 112 | 48 | 7.3 x 10.9 | 213 | 15.9 |
| 3.6 | 122 | 47 | 6.7 x 10.0 | 223 | 18.4 |
| 4.0 | 136 | 46 | 6.0 x 9.0 | 236 | 21.9 |
| 4.3 | 147 | 46 | 5.6 x 8.4 | 246 | 24.8 |
| 4.6 | 157 | 45 | 5.2 x 7.8 | 256 | 27.9 |
| 5.0 | 172 | 44 | 4.8 x 7.2 | 270 | 32.3 |

Table 16: M-40mm f/2.8 (Lens Reversed)(Distance scale set to ∞)

| Magnification | Bellows Extension | Working Distance | Photographing Area | Film-to-Object Distance | Exposure Factor |
|----------------------|--------------------------|-------------------------|---------------------------|--------------------------------|------------------------|
| 1.3 | 48 | 70 | 18.5 x 27.7 | 171 | 4.5 |
| 1.6 | 61 | 64 | 15.0 x 22.5 | 178 | 5.8 |
| 2.0 | 77 | 59 | 12.0 x 18.0 | 189 | 7.9 |
| 2.3 | 90 | 56 | 10.4 x 15.7 | 199 | 9.7 |
| 2.6 | 102 | 54 | 9.2 x 13.8 | 209 | 11.7 |
| 3.0 | 119 | 52 | 8.0 x 12.0 | 224 | 14.6 |
| 3.3 | 131 | 51 | 7.3 x 10.9 | 235 | 16.9 |
| 3.6 | 144 | 50 | 6.7 x 10.0 | 246 | 19.5 |
| 4.0 | 160 | 49 | 6.0 x 9.0 | 262 | 23.2 |
| 4.3 | 173 | 48 | 5.6 x 8.4 | 274 | 26.2 |

Table 17: A-50mm f/1.4 (Lens Reversed)(Distance scale set to ∞)

| Magnification | Bellows Extension | Working Distance | Photographing Area | Film-to-Object Distance | Exposure Factor |
|----------------------|--------------------------|-------------------------|---------------------------|--------------------------------|------------------------|
| 1.0 | 57 | 90 | 24 x 36 | 200 | 3.2 |
| 1.2 | 68 | 82 | 20 x 30 | 202 | 3.9 |
| 1.4 | 78 | 75 | 17 x 26 | 206 | 4.7 |
| 1.6 | 88 | 71 | 15 x 23 | 212 | 5.6 |
| 1.8 | 99 | 67 | 13 x 20 | 219 | 6.6 |
| 2.0 | 109 | 64 | 12 x 18 | 226 | 7.7 |
| 2.2 | 120 | 62 | 11 x 16 | 234 | 8.9 |
| 2.4 | 130 | 60 | 10 x 15 | 243 | 10.1 |
| 2.6 | 141 | 58 | 9 x 14 | 252 | 11.4 |
| 2.8 | 151 | 57 | 9 x 13 | 261 | 12.8 |
| 3.0 | 161 | 56 | 8 x 12 | 270 | 14.3 |
| 3.2 | 172 | 54 | 8 x 11 | 279 | 15.8 |

Table 18: M-50mm f/1.4 (Lens Reversed)(Distance scale set to ∞)

| Magnification | Bellows Extension | Working Distance | Photographing Area | Film-to-Object Distance | Exposure Factor |
|----------------------|--------------------------|-------------------------|---------------------------|--------------------------------|------------------------|
| 1.0 | 55 | 89 | 24 x 36 | 197 | 3.0 |
| 1.2 | 65 | 80 | 20 x 30 | 198 | 3.7 |
| 1.4 | 75 | 74 | 17 x 26 | 202 | 4.6 |
| 1.6 | 85 | 69 | 15 x 23 | 208 | 5.4 |
| 1.8 | 95 | 66 | 13 x 20 | 215 | 6.4 |
| 2.0 | 106 | 63 | 12 x 18 | 222 | 7.5 |
| 2.2 | 116 | 61 | 11 x 16 | 230 | 8.6 |
| 2.4 | 126 | 59 | 10 x 15 | 238 | 9.8 |
| 2.6 | 136 | 57 | 9 x 14 | 247 | 11.1 |
| 2.8 | 146 | 56 | 9 x 13 | 256 | 12.5 |
| 3.0 | 157 | 55 | 8 x 12 | 265 | 13.9 |
| 3.2 | 167 | 54 | 8 x 11 | 274 | 15.5 |

CLOSE-UP TABLE FOR SLIDE COPER A

When you make duplications with the Slide Copier A, refer to the close-up table below.

Adjust the Slide Copier A runner to the Slide Copier scale according to the lens you use.

| Lens | Slide | Strip Film | Magnification |
|--------------------------------|--------------|-------------------|----------------------|
| SMC Pentax-M 50mm f/1.4 | -5 scale | -6 scale | 1.0 |
| SMC Pentax-A 50mm f/1.4 | -4 | -5 | 1.0 |
| SMC Pentax-M and -A 50mm f/1.7 | -2 | -3 | 1.0 |
| SMC Pentax-M 50mm f/2 | -2 | -3 | 1.0 |
| SMC Pentax-A Macro 50mm f/2.8 | 0 (X1) | -1 | 1.0 |
| SMC Pentax-M Macro 50mm f/4 | 0 (X1) | -1 | 1.0 |

HOW TO ASSEMBLE SLIDE COPIER A

1. Remove the stopper screw from the end of the monorail and attach the slide copier to the rail by lining up both rails and tightening the screw.

2. When using a 49mm filter size lens, remove the ring adaptor **A** from inside the slide copier standard by pressing the two knobs **B** on the sides of the standard and attach the adaptor to the

front of the lens (NOTE: The adaptor is not needed with 52mm filter size lenses; in this case put it away for safe keeping).

3. Extend the front standard of the bellows until its base hits the rail of the slide copier **A**. Tighten the front standard clamp knob. Set the distance scale of the lens at infinity.

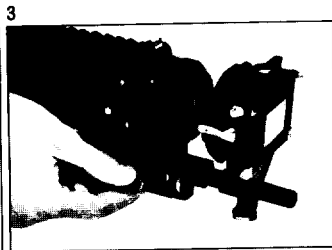
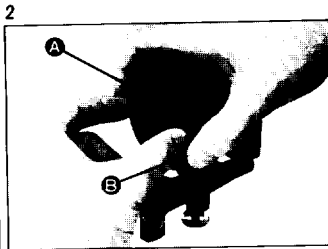
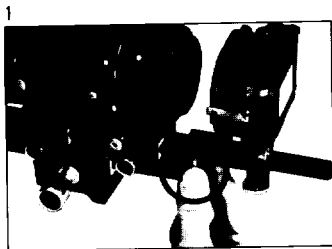

4. To fit the Slide Copier panel to the lens, first release the panel from the spring clamp. Then, press the knurled protrusions **B** on both sides of the panel, slide the panel over the front end of the lens and release the panel protrusions.

4

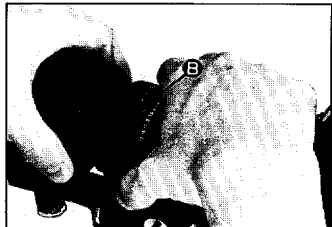

5. Insert the slide to be duplicated into the slide slot **C** of the slide holder. The slide holder can be moved several millimeters vertically to facilitate cropping when you make duplicates at more than 1X magnification. Position the slide holder at the central click-stop for regular 1X duplicate making.

5

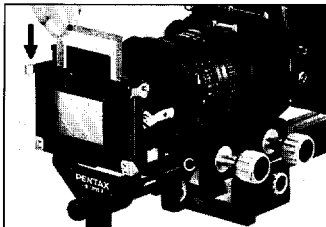

6. When using the 50mm Macro lens, align the front end of the Slide Copier A runner (marked with a red dot) with the line marked "MACRO LENS X1" on the Slide Copier scale. For other lenses, look up the alignment table on page 51.

6

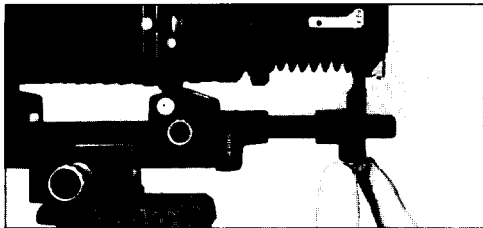

54

7. For regular duplicate making, mount the lens (50mm Macro lenses are recommended) on the bellows normally and use the NORMAL scale. Refer to the close-up tables to find the amount of bellows extension for the particular lens you use.

7

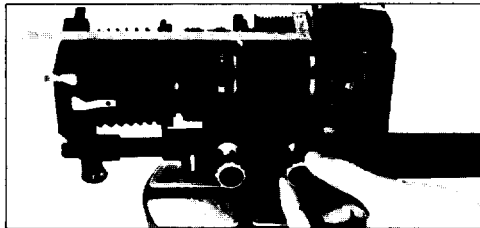

Reverse

When you want to crop the original slides while making the copies, increase the magnification. For instance, if you magnify the image to 1.5X, you can crop the original by 1/3 both vertically and horizontally. When you will magnify the image more than 1.2X, you have to mount the lens on the bellows in reverse direction. To reverse the lens direction, follow the instruction on pages 14 to 17 and fix the set-up as shown in the photograph at right. When attaching the slide copier to the lens reversed, remove the lens mounting ring of the slide copier and screw it in the rear end of the bellows' front standard. Then attach the slide copier panel over it. Do not forget to flip the scale over to REVERSE. Extend the bellows to the front edge of the monorail. Then, turn the focusing ring of the lens to infinity. Now you are all set.

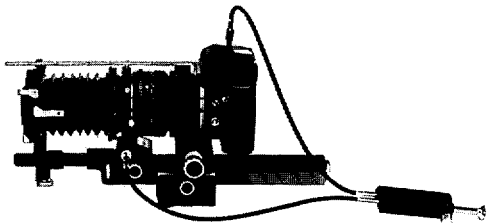

Focusing

Adjust the focus by rotating the rear standard extension knob while looking through the viewfinder. The lens position must remain fixed, so the front standard extension knob should not be adjusted at this stage.

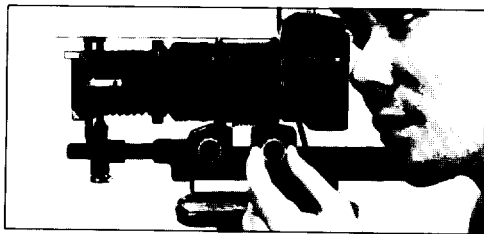

56

Copying Film Strips

1. When you copy a strip film, align the two openings in the strip film holder arm with the pins found on the slide holder, and push the holder down to fix. Fix the proper one on each side of the slide holder. To remove the strip film holders, push them upward.



2. Open the retainer plate (which includes the ground glass window) attached to the slide holder, and carefully insert the strip film. Close the retainer plate again.

3. Wind both ends of the strip film around the strip film holders to prevent any damage to the

2



film surface. The strip film is unloaded by opening up the retainer plate. Focusing is adjusted as before, by turning the rear plate extension knob. The strip film however, lies in a plane about 3mm further away than ordinary slides. Therefore, move the slide copier runner by 3mm or 1-1/2 notches on the slide copier scale toward the lens.

3

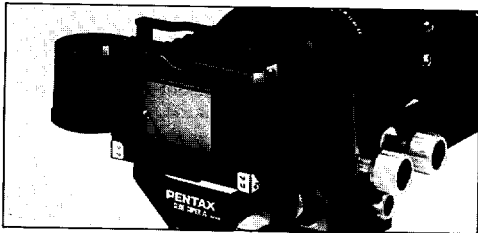

HOW TO USE SLIDE COPIER A

Illumination

1. During the day, the simplest method is to face the equipment toward the sky. But on very fine days, the blue sky will tend to tint the copies a shade of blue. For reversal color films, the shutter speed should be faster than 1/10 sec. due to the reciprocity failure described on page 22. This should be relatively simple if you direct the slide copier toward the sun. However, note that color slides tend to "curl" if exposed to the sun too long. Another point to remember is that the sun striking the ground glass window at an angle exceeding 45 degrees may cause shadows of the slide holder retaining plate to cast on the slide.

2. At night, use a 500W color photographic floodlight (reflector lamp). The brightness varies greatly with distance. Adjust the distance of the lamp so that you can get a faster than 1/10 sec. shutter speed.

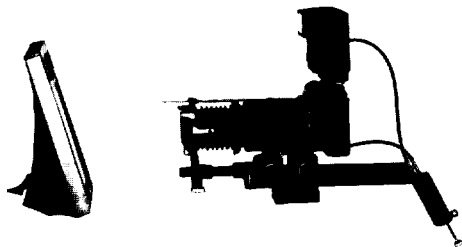

3. The most convenient and easiest method is to use a Pentax TTL Auto Flash in combination with the Super A, Super Program or LX. You can either mount the TTL Auto Flash on the hotshoe of the camera or set it behind the slide copier and connect it to the camera with 4P Synchro Cord B 5 m and Hotshoe Grip. Either way, the TTL Auto Flash is controlled by the camera's Off-Film-Reflection metering system and you can obtain correct exposure always. When the TTL Auto Flash is placed directly behind the slide copier, it is recommended to use a small lens opening or some translucent diffuser to reduce the light emission of the flash. When you mount the flash on the hotshoe of the camera, place a white reflector behind the slide copier.

The Macro lens is most suited for the slide copying. Although it is better to use small apertures, provided that the original slide is flat enough, you can even wide open aperture for duplicating work. In the case of other lenses, small lens opening are recommended to avoid image deterioration at corners.

Osaka, Tokyo 100-91, JAPAN
Avenue 3-5, 1930 Zaventem Zuid-7, BELGIUM
Postfach 54 0169, 2000 Hamburg 54, WEST GERMANY
100, South Hill Avenue, South Harrow, Middlesex HA2 0LT, U.K.
12, Rue Ambroise-Croizat, 95100 Argenteuil, FRANCE
Case 2, 8305 Dietlikon ZH, SWITZERLAND
S-127 Uppsala, SWEDEN
3815 HR Breda, THE NETHERLANDS
Drive East, Englewood, Colorado 80112, U.S.A.
Avenue, Vancouver, B.C. V6J 1K5, CANADA
Ltda. Rua Capitão Antonio Rosa 376, Sala 121 Ed. PBK, São Paulo, BRASIL

06966 ENG

Specifications are subject to change without notice.

7/84 Printed in Japan