

# PENTAX

VHS VIDEO CAMERA/RECORDER

## MODEL PV-C67A

### INSTRUCTION MANUAL

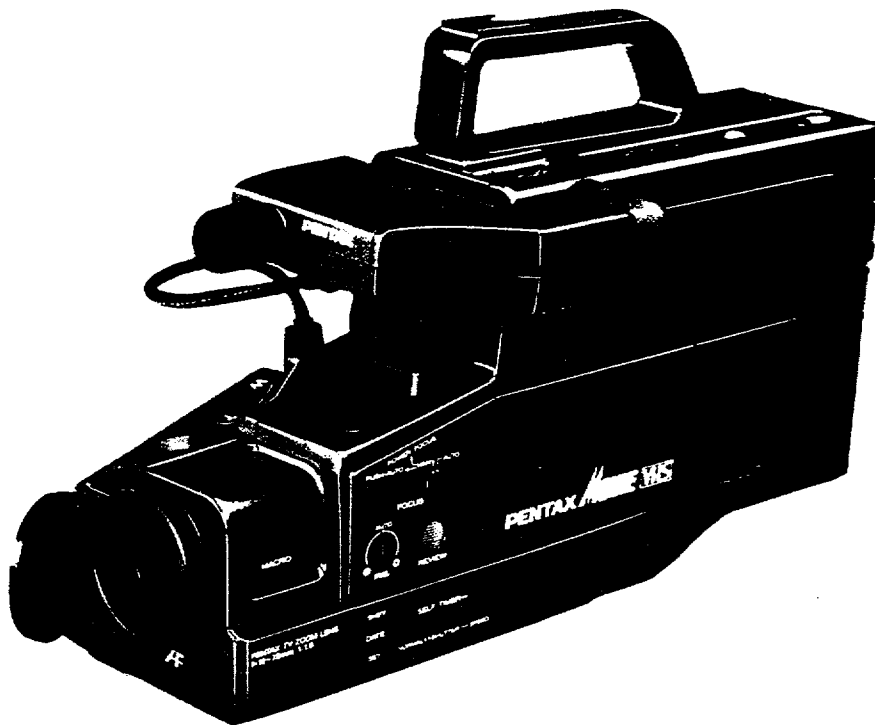

PENTAX **MOVIE**

**WARNING: TO PREVENT FIRE OR SHOCK HAZARD, DO NOT EXPOSE THIS UNIT TO RAIN OR MOISTURE.**

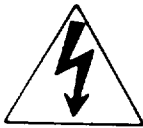

**CAUTION**

**RISK OF ELECTRIC SHOCK  
DO NOT OPEN**



**CAUTION:** TO REDUCE THE RISK OF ELECTRIC SHOCK, DO NOT REMOVE COVER (OR BACK). NO USER — SERVICEABLE PARTS INSIDE. REFER SERVICING TO QUALIFIED SERVICE PERSONNEL.

This symbol warns the user that uninsulated voltage within the unit may have sufficient magnitude to cause electric shock. Therefore, it is dangerous to make any kind of contact with any inside part of this unit.

This symbol alerts the user that important literature concerning the operation and maintenance of this unit has been included. Therefore, it should be read carefully in order to avoid any problems.

## DEW (MOISTURE CONDENSATION)

Moisture condensation may occur if the video camera/recorder is moved from a cold area to a warm humid area. A flashing "POWER" light indicates that moisture is on the recorder mechanism, which could result in damage to the tape. When the "POWER" light is flashing the unit will not operate. In this condition, press the "EJECT" button, remove the tape, and wait for the moisture to dry (until the "POWER" indicator stops flashing).

"DEW" ("POWER") Light

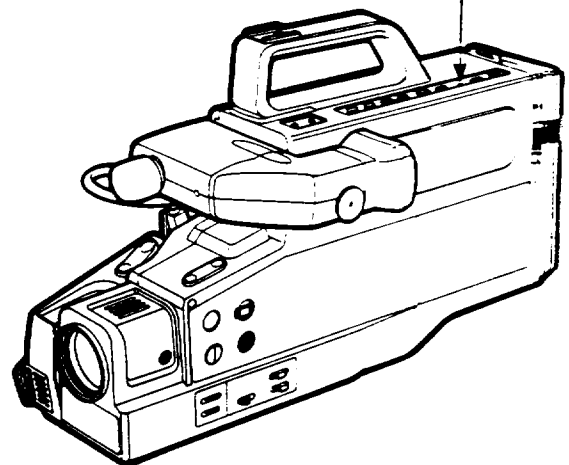

Read the Important Safety Instructions for AC Adaptor/Charger before use.

## PRECAUTIONS

■ **No water, dust or sand**

Be careful that no water, dust or sand enters the Camera/Recorder because it may cause damage.

- The solid-state image sensor is basically immune to direct sunlight or excessively bright objects, however, avoid prolonged exposure to these adverse objects since unnecessary heat may develop.
- When you are not using the Camera/Recorder, switch off the power and attach the lens cap.

- Be sure not to leave it in a place where the temperature exceeds 120°F, or the pickup device may be damaged. Be careful not to leave the unit in the following places:

- Inside a car with the windows closed and in direct sunshine.
- Near heating appliances.
- In direct sunshine in summer.



- Do not leave the viewfinder lens facing sunlight for a prolonged period, or the phosphorescent surface of the cathode ray tube may be damaged.

Congratulations on buying the **VHS** Video Camera/Recorder. For maximum pleasure and convenience please read these simple instructions before operating your Camera/Recorder.

**WARNING:** Many television programs are copyrighted. One court has held that private, non-commercial, in-home video taping of copyrighted televised programs constitutes copyright infringement. Purchasers are advised not to copy such programs.

\* **HQ** This Video Camera/Recorder with this marking incorporates **VHS** high-quality picture technology and is compatible with any Video Cassette Recorder bearing the **VHS** mark.

## FEATURES

- Solid-state camera pickup
- **HQ** High Quality picture technology
- Auto Focus Power Zoom Lens with macro feature
- Electronic Viewfinder
- Full record and playback capability with standard **VHS** cassette

## ACCESSORIES

Check to make sure you have the following components and accessories (besides the Camera/Recorder Unit itself) before disposing of the packing material.

1. Earphone
2. Ni-cd rechargeable Battery Pack (1-hour type)
3. AC Adaptor/Charger
4. RF Converter Unit (with Cable, 1.5 m)
5. 75-ohm Coaxial Cable with Antenna Adaptor (75/300-ohm), 1.5 m
6. Antenna Adaptor (300-ohm to 75-ohm)
7. Audio/Video Output Cable
8. Shoulder Strap
9. Audio/Video Input Cable
10. Audio/Video Input Adaptor

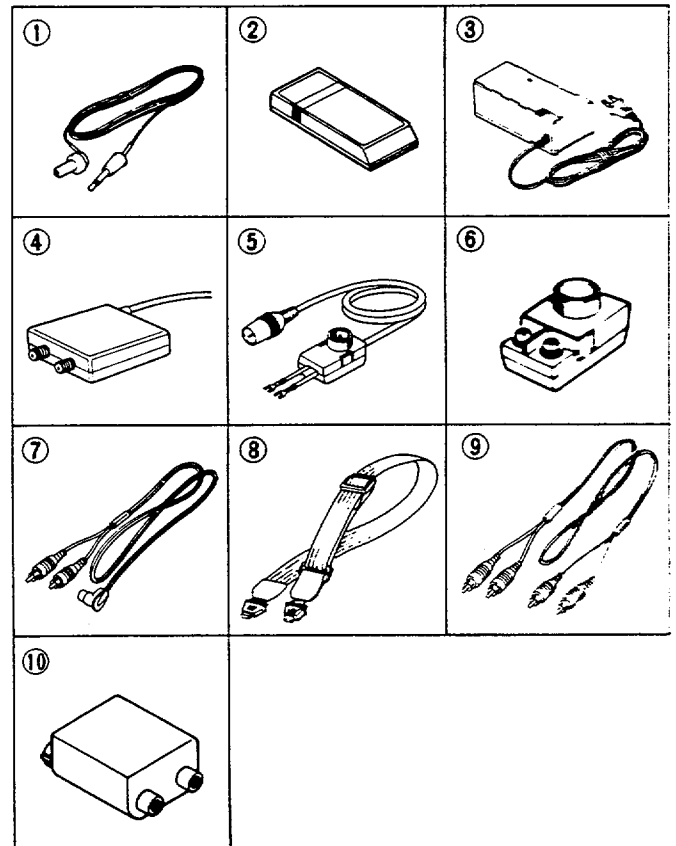

# TABLE OF CONTENTS

Features.....	2	Setting the date.....	21
Accessories.....	2	Eyepiece adjustment.....	22
Electronic viewfinder position adjustment .....	3	Producing best color program .....	22
How to install the shoulder strap.....	4	Connections and operations for viewing the picture played back on your TV .....	23
Power sources.....	4	Connections and operations for recording TV program .....	25
Checking the battery pack .....	6	Using the F-search and R-search features .....	26
Charging the battery pack .....	6	Using the still feature .....	27
Making a sample camera recording .....	7	Using the memory feature .....	27
Identification and operation of controls .....	9	Operating hints .....	27
Using the auto focus feature .....	15	Camera/Recorder to VTR dubbing.....	28
Using the shutter speed control feature.....	17	Tape counter digit/minute chart (approx. figures).....	28
Using the self timer feature.....	18	Troubleshooting.....	29
Using the power zoom feature .....	19	Head cleaning .....	31
Using the macro feature .....	19	Periodic maintenance .....	31
Using the instant review feature .....	20	Specifications .....	31
Using the auto iris feature.....	20	Optional accessories.....	32
Using the fade-in/fade-out feature.....	20		

## ELECTRONIC VIEWFINDER POSITION ADJUSTMENT

The position of the Electronic Viewfinder can be adjusted so it can be viewed with the left eye as well as the right eye.

- When viewing with right eye

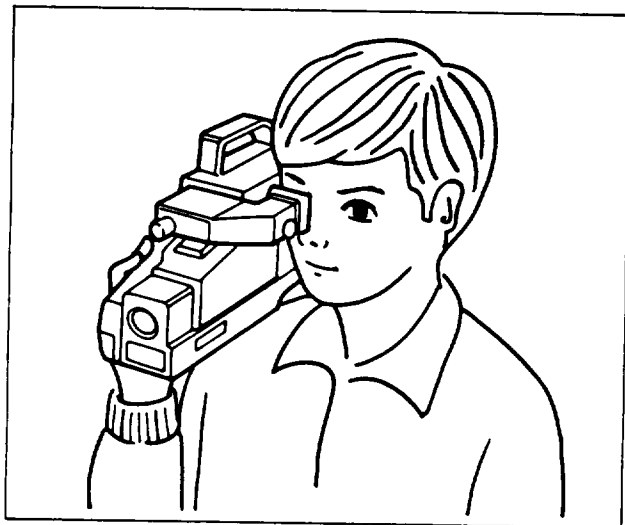

- When viewing with left eye

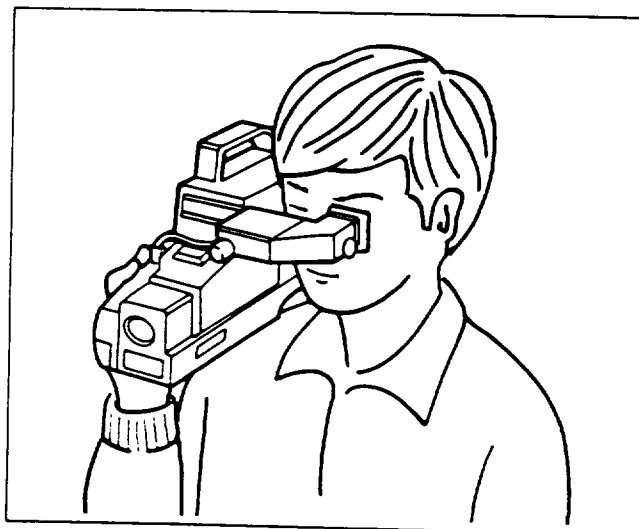

# HOW TO INSTALL THE SHOULDER STRAP

Attach the Shoulder Strap (Accessory No. 8), as illustrated.

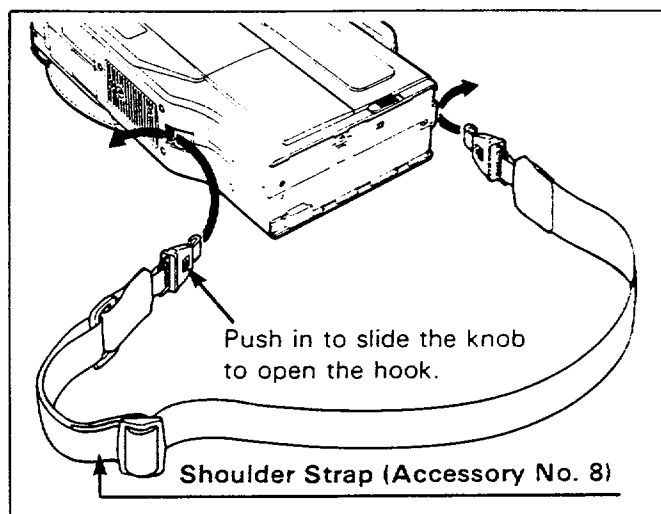

## POWER SOURCES

### ■ WHEN USING WITH THE BATTERY PACK (Accessory No. 2)

1. Be sure that the Power Terminal Protection Cover is in the uppermost position and it is covering the Terminal.
3. To remove slide the Battery Pack upward while holding the "BAT" Eject Lever downward.

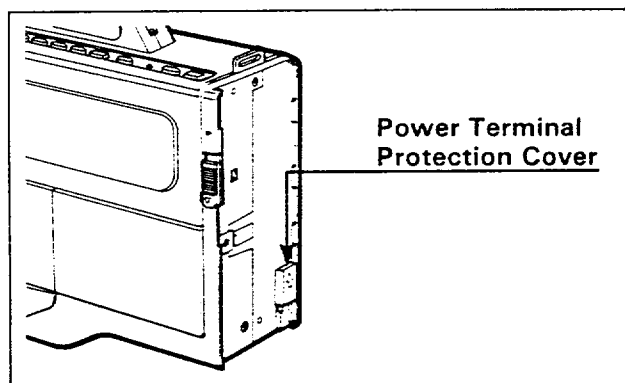

2. To attach align the notch on the side of the Battery Pack (Accessory No. 2) with mark "▶" on the rear left side of the Video Camera/Recorder so that the Battery fits in the grooves (flat against the rear of the Camera/Recorder), and slide the Battery Pack downward, as illustrated.

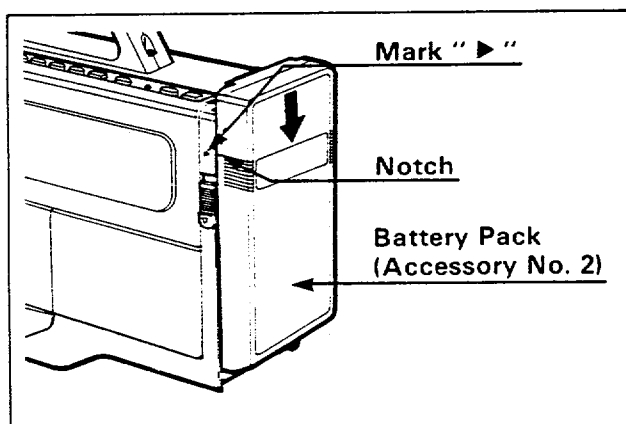
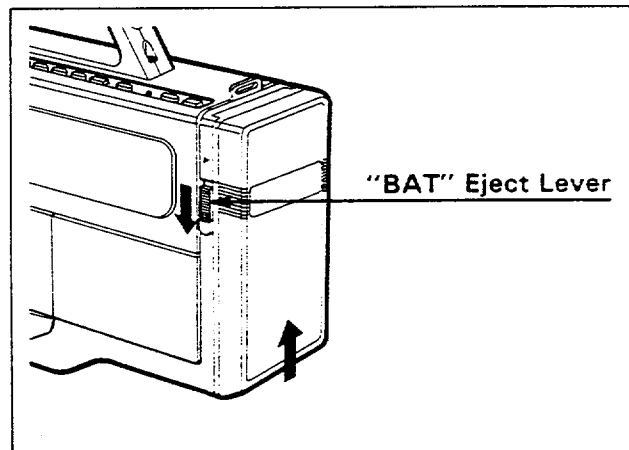

■ **WHEN USING WITH THE AC ADAPTOR/CHARGER (Accessory No. 3)**

1. Be sure that the Power Terminal Protection Cover is in the uppermost position and it is covering the Terminal.

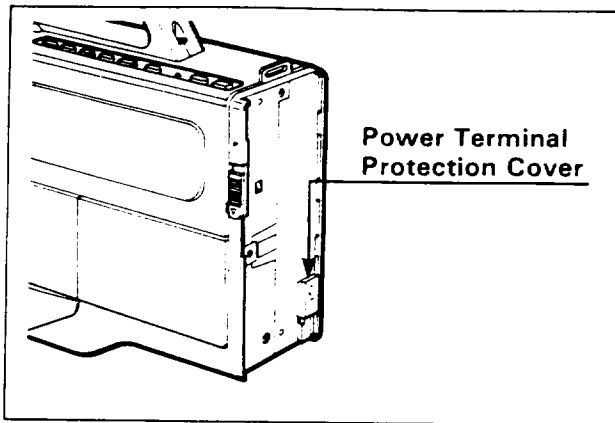

3. Plug the AC Adaptor Charger power cord into AC electrical outlet.

**NOTE:** Do not press "CHARGE" Button on the AC Adaptor/Charger. If you press the Button, the power of the Video Camera Recorder will shut off.

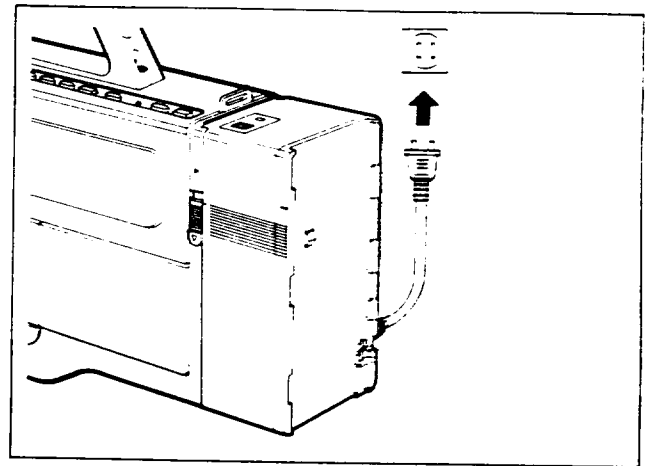

2. To attach align the notch on the side of the AC Adaptor/Charger (camera side) (Accessory No. 3) with mark "▶" on the rear left side of the Video Camera/Recorder so that it fits into the grooves and is flat against the rear of the Camera/Recorder, and slide the AC Adaptor/Charger downward as illustrated.

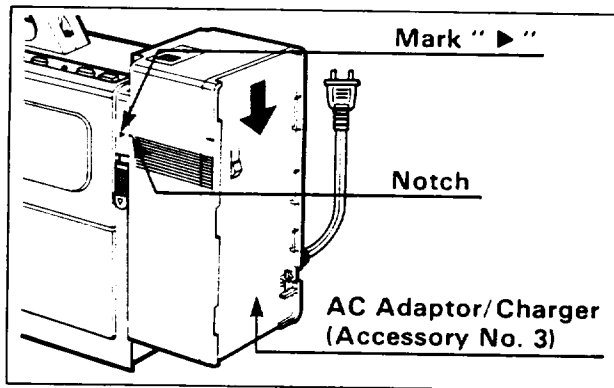

4. To remove slide the AC Adaptor/Charger upward while holding the "BAT" Eject Lever downward.

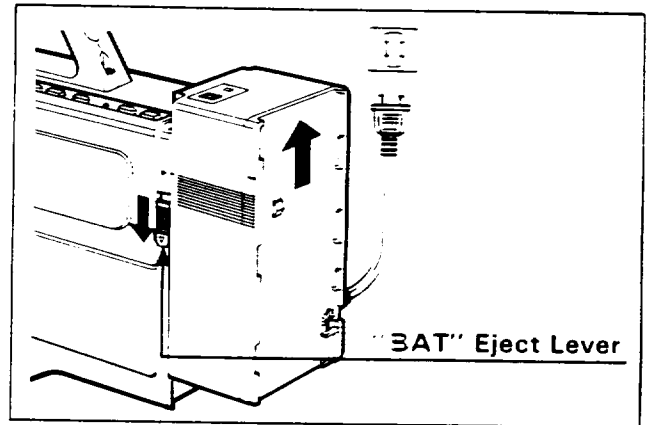

■ **WHEN USING WITH THE CAR BATTERY (By using optional car battery cord PC-YC12)**

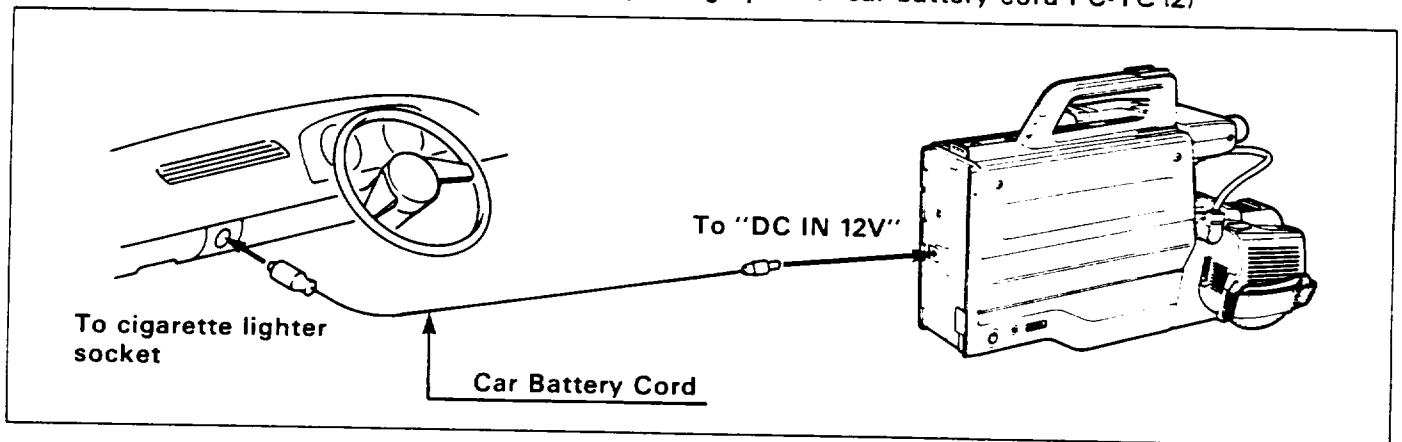

1. Connect car battery cord to the "DC IN 12V" jack of the Video Camera Recorder and the car's cigarette lighter socket.

**NOTE:** The Car Battery Cord is designed to be used only with automobiles having a 12-volt negative ground system.

## CHECKING THE BATTERY PACK

When the "E" indication in the Electronic Viewfinder appears and flashes while the Video Camera/Recorder is operated with a Battery pack (Accessory No. 2) during recording, it indicates that the battery charge is insufficient. Then, charge it or replace it with a charged battery pack.

**NOTE:** Whenever the tape counter display is present in the viewfinder, it appears with a 3-dash read-out indicating the condition of Camera/Recorder battery power. When the battery is fully charged, the display reads "E---F".

When the battery is very near empty, only one dash remains. When the last dash starts blinking, you should find an alternative power source or recharge the battery before continuing to use your Camera/Recorder.

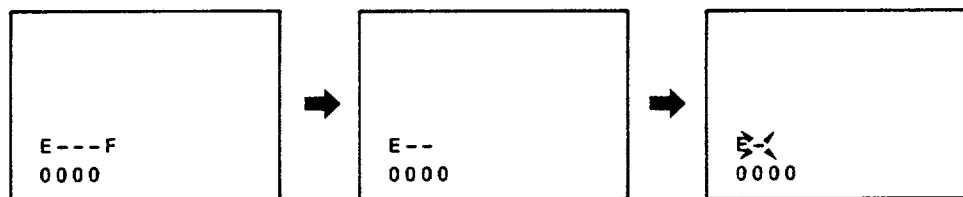
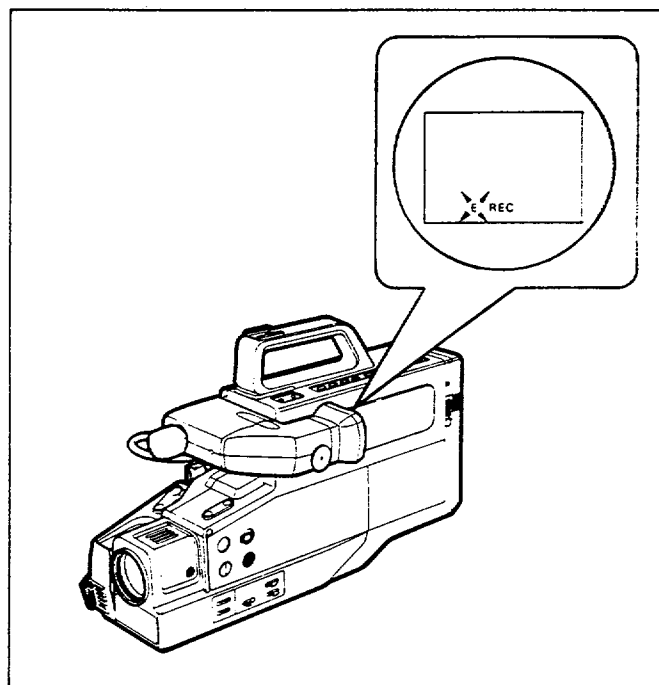

## CHARGING THE BATTERY PACK

1. Attach the Battery Pack to the AC Adaptor/Charger (battery side) (Accessory No. 3).
2. Plug the AC Adaptor/Charger power cord into AC outlet.
3. Press "CHARGE" Switch. The Charge Indicator Light will be lighted while the Battery is accepting a charge, and will go out when the Battery is fully charged.

### NOTES:

1. The AC Adaptor/Charger may be left attached to the Video Camera/Recorder during the Battery charging operation, but it cannot be used to power the Video Camera/Recorder while charging the Battery Pack.
2. The time for Battery charging is approx. one hour for 1-hour type Battery pack (Accessory No. 2).
3. An optional long play Battery may also be charged by this AC Adaptor/Charger. This Battery will operate the Camera/Recorder for about 2 hours.

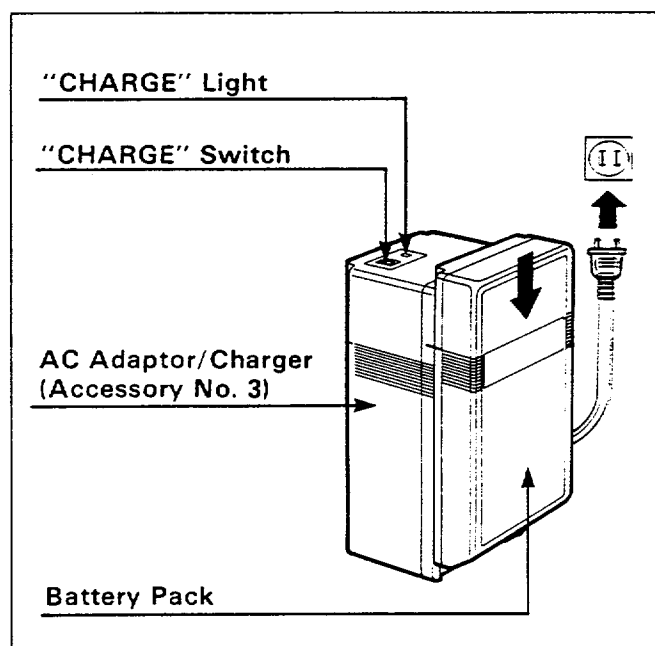

# MAKING A SAMPLE CAMERA RECORDING

1. Connect the POWER SOURCE. (See pages 4 and 5.)
2. Press "EJECT" Button and insert the cassette so the transparent window is toward you and the arrow toward the Cassette Holder. Slide the Cassette into Cassette Holder as far as it will go.

**NOTE:** If the power source is not connected to Camera/Recorder, the Cassette Holder will not open.

3. Press the Cassette Holder. The Holder will latch in the operating position.

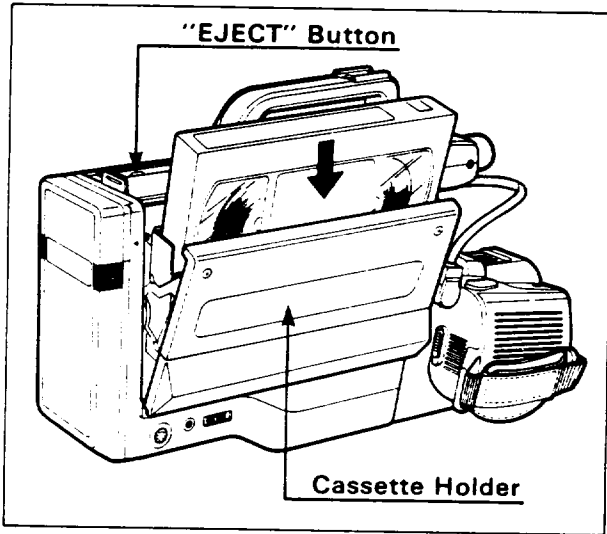

4. Set "VIDEO/CAM" Select Switch to "CAM" position.
5. Press "POWER" ON/OFF Button on. The Video Camera/Recorder will enter record/pause mode automatically.

**NOTE:** If the erase prevention tab on the cassette is removed, the Camera/Recorder will not enter record/pause mode and recording is not possible.

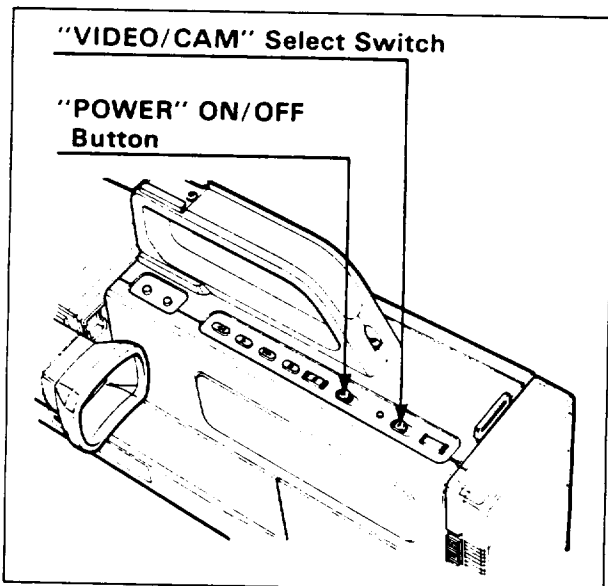

6. Set "IRIS" Control to "AUTO".
  7. Set "FOCUS AUTO MAN" Switch to "AUTO".
- NOTE:** See page 22 for "EYEPIECE ADJUSTMENT".

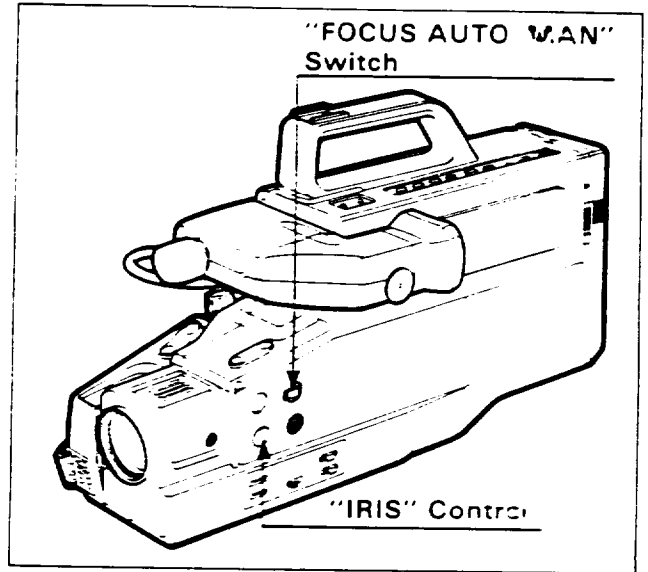

8. Now, press Record Start Stop Button to start shooting the picture. "REC" indication appears in the viewfinder and you are now recording the picture you see through the Electronic Viewfinder.
9. Press Record Start Stop Button to stop recording. Press the Button again to resume recording. The "REC" indication in the Electronic Viewfinder goes off in the record/pause (stand-by) mode.

**NOTE:** Do not leave the Camera/Recorder in this mode for a prolonged period of time, or the video heads may be damaged.

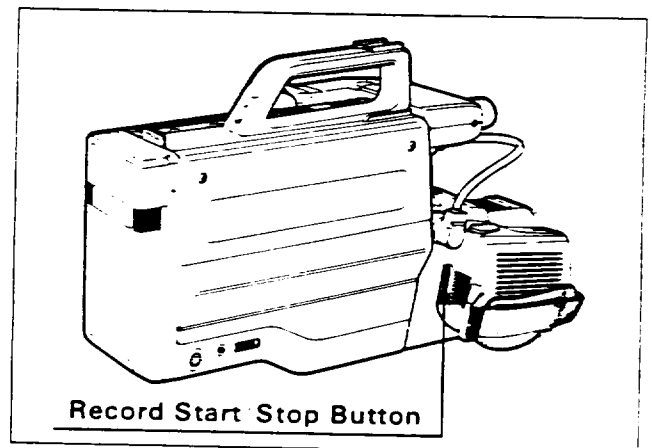



10. After recording, set "VIDEO/CAM" Select Switch to "VIDEO", and the Camera/Recorder will be now in the stop mode.

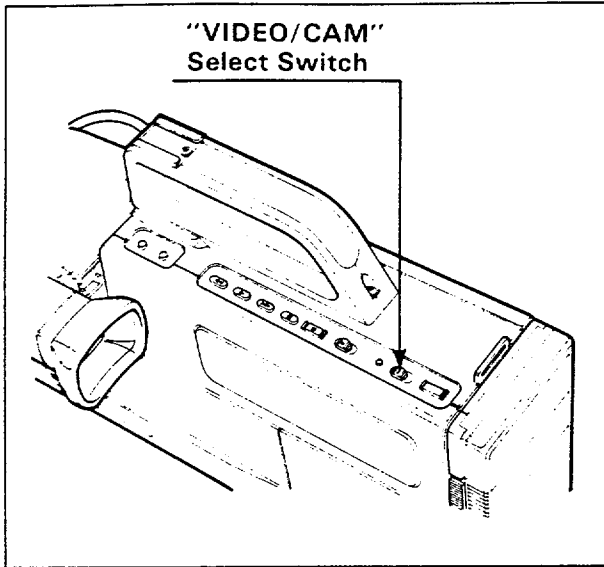

11. Press "REW" Button. The tape will be rewound to the beginning.
12. Press "PLAY" Button. The picture you just recorded will be seen through the Viewfinder and sound can be heard by earphone.

**NOTE:** If you connect the Video Camera/Recorder to your TV, you can see the picture played back on your TV. Refer to "CONNECTIONS AND OPERATIONS FOR VIEWING THE PICTURE PLAYED BACK ON YOUR TV" on pages 23 and 24.

13. After playing, press "STOP" Button.

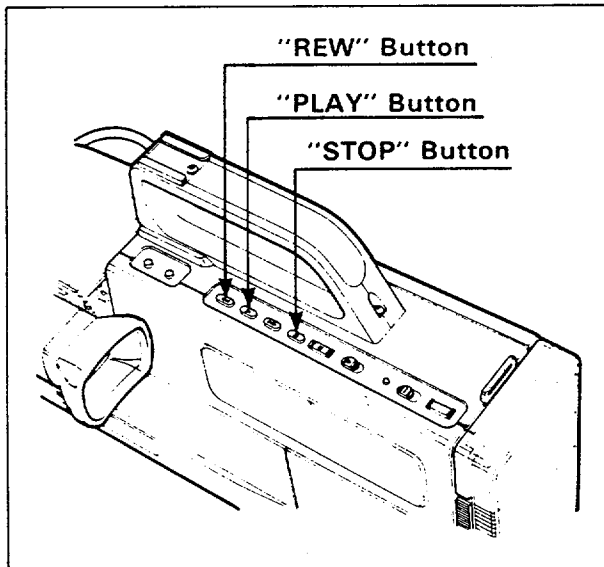

14. Press "POWER" ON/OFF Button off and then "EJECT" Button to remove cassette.

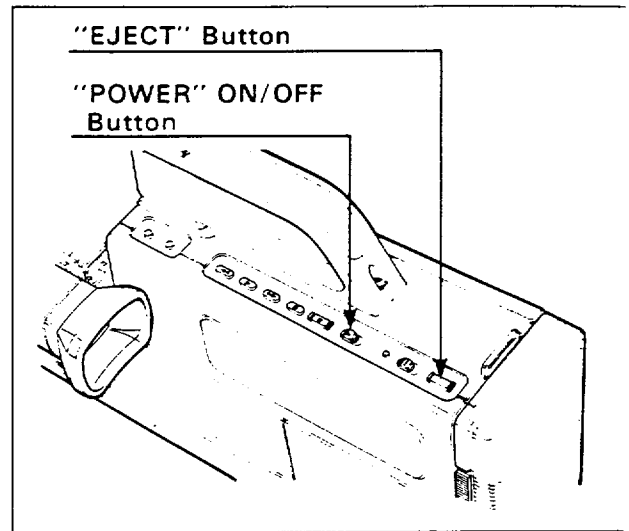

15. Always remove the power source from the Video Camera/Recorder after use.

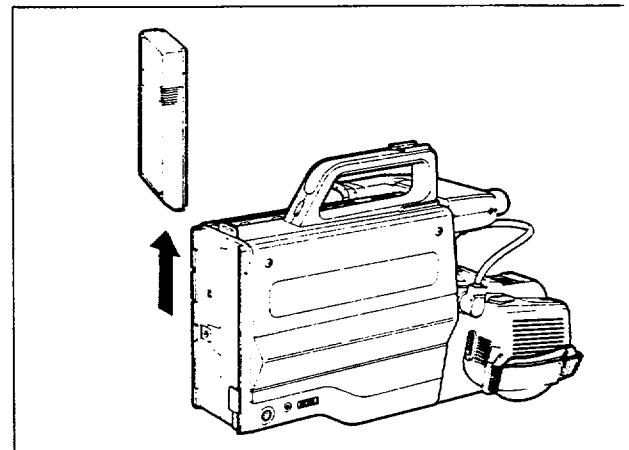

**NOTE:** If you have a cassette tape that has already been partially recorded on and you want to record the remaining blank section, follow the procedure below.

1. Play back the tape and press "STILL/REC/PAUSE" Button at the end of the previously recorded section.
2. Set "VIDEO/CAM" Select Switch to "CAM". The Camera/Recorder enters the record pause (stand-by) mode.
3. Press Record Start/Stop Button.

# IDENTIFICATION AND OPERATION OF CONTROLS

## Microphone

Sensitive to sounds coming from the direction in which the camera is pointed.

## Record Indicator

Flashes for about 10 seconds when the "SELF TIMER" Switch is pressed during record pause (stand-by) mode and stays on to indicate recording starts.

## Power Zoom Switch

This switch performs zooming electrically.

"W": Picture becomes wider gradually.

"T": Picture becomes telescopic gradually.

## "POWER FOCUS" Buttons

Set "FOCUS AUTO/MAN" Switch to "MAN" position and then focus on the object by pressing these Buttons for manual focusing.

## "PUSH AUTO" Focus Button

Auto focusing can be also performed during manual focus mode by pushing this Button.

## Lens (with Lens Cap)

F1.6 (12-72 mm) 6:1 power zoom lens features auto focus and auto iris functions.

## "MACRO" Button

Used to shoot objects as close as 1 cm from the lens tip.

(See "USING THE MACRO FEATURE" on page 19.)

## Auto Focus Window

To automatically focus the camera lens, this window transmits and receives infrared light which is reflected off the object. Make sure you don't obstruct this window when recording.

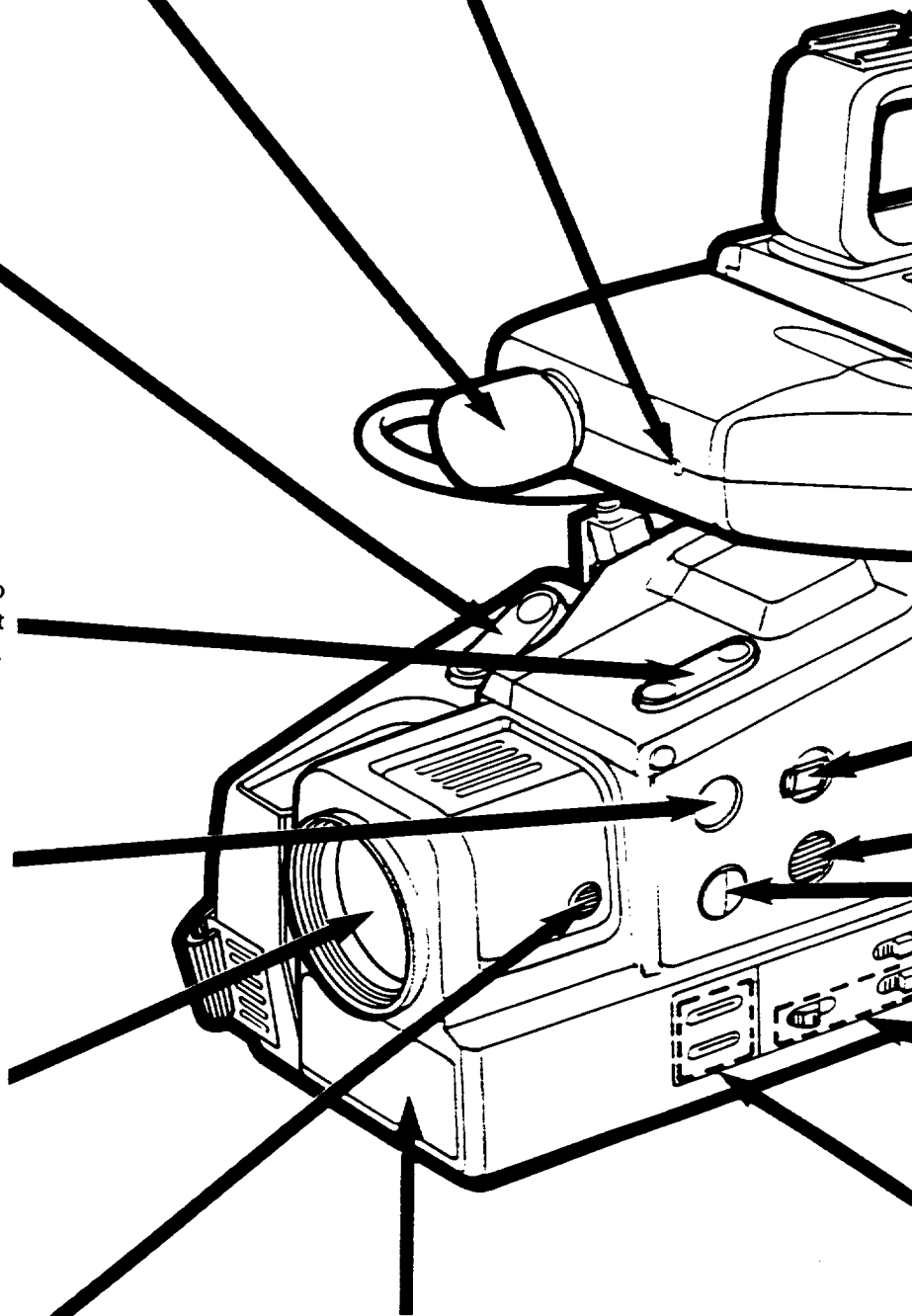



### Accessory Shoe

Used to attach a Camera Light (Not supplied).

### Electronic Viewfinder (EVF)

Displays what the Camera/Recorder lens sees. The electronic viewfinder also functions as a convenient black-and-white monitor during playback of recorded material.

### "BAT"tery Eject Lever

Releases the Battery or the AC Adaptor/Charger attached to the Video Camera/Recorder.

### Diopter Control

To use the electronic viewfinder without eye-glasses on, turn this control knob for your optimum focus adjustment.

### "FOCUS AUTO/MAN" Switch

Set this Switch to the "AUTO" position for automatic focusing, and to the "MAN" position for focusing with the Power Focus Buttons.

### "REVIEW" Button

Used to review the last few seconds of the recorded segment in the record/pause mode.

### "IRIS" Control

When this Control is in the "AUTO" position, the iris is controlled automatically. Turn this Control to the right or left for manual iris control.

### "SELF TIMER" Switch

This Switch allows you to start recording after about 10 seconds when the Switch is pressed. (See "USING THE SELF TIMER FEATURE" on page 18.)

### "DATE" Set Buttons

Used to set the date during pause (stand-by) mode. (See "SETTING THE DATE" on page 21.)

### "SHUTTER SPEED" Control Switches

Used to control the shutter speed during recording and/or record/pause (stand-by) mode. (See "USING THE SHUTTER SPEED CONTROL FEATURE" on page 17.)

### "REW" Button

Press this Button during Stop or Fast forward mode, and fast-rewinding starts. "REW" indication appears in the viewfinder whenever the tape counter is present. Press the Button during playback of tape, and the tape is played back in the rewind direction approximately 3 times faster than the normal speed to confirm the recorded contents.

Press "PLAY" Button to return to normal playback mode or press "STOP" Button to stop tape movement.

### "PLAY" Button

Used for playback of tape recorded in the SP mode.

### "DISPLAY" Button

When "VIDEO/CAM" Select Switch is set to "VIDEO" position, pressing this Button causes battery indicator and 4-digit tape counter to appear in the Camera/Recorder's electronic viewfinder. Press the Button again to delete all displays.

When "VIDEO/CAM" Select Switch is set to "CAM" position, pressing this button causes the 6-digit date display to appear in the viewfinder. Pressing the Button again will cause battery indicator and 4-digit tape counter to appear in the viewfinder.

Pressing the "DISPLAY" Button once more clears all graphics from the viewfinder.

### "COUNTER RESET" Button

Press to reset the Tape Counter to "0000".

#### NOTE:

- Tape Counter and Date displays are stored for about four hours even if power is turned off.

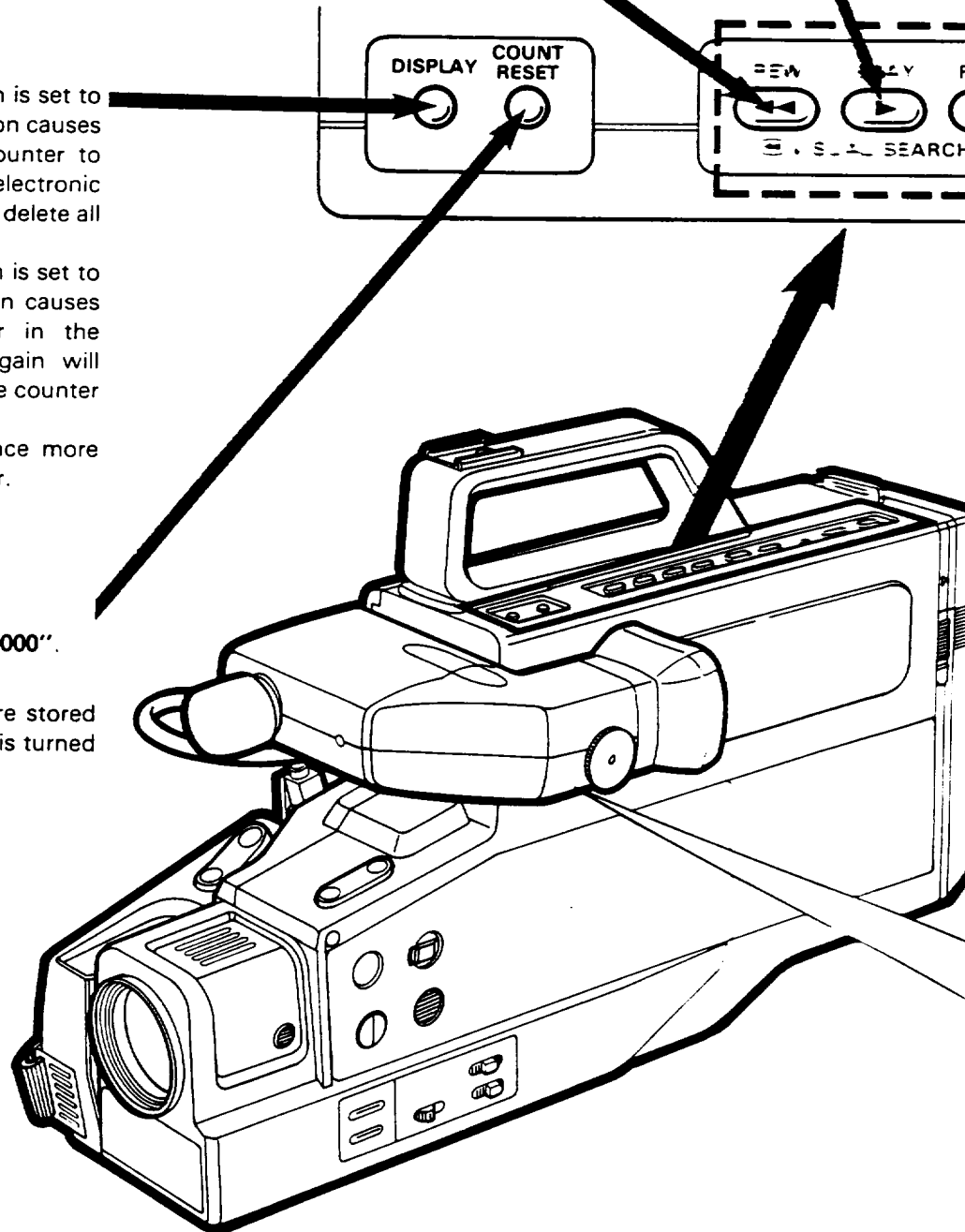

### "F.FWD" Button

Press this Button during Stop or Rewind mode, and fast-forwarding starts. "FF" indication appears in the viewfinder whenever the tape counter display is present.

Press the Button during playback of tape, and the tape is played back in the forward direction approximately 3 times faster than the normal speed to confirm the recorded content.

Press "PLAY" Button to return to normal playback mode or press "STOP" Button to stop tape movement.

### "STILL/REC/PAUSE" Button

When this button is pressed during recording, the tape stops and the Camera/Recorder enters the record pause (stand-by) mode. When this button is pressed again, the tape runs to resume recording. This button may be also used to display a still picture during playback mode.

### "EJECT" Button

Operates with "POWER" either on or off, if a power source is connected to the Camera/Recorder.

### "VIDEO/CAM"era Select Switch

This Switch changes the Camera/Recorder to the record mode or to the playback mode. The Switch must be in "CAM"era position for recording.

### "POWER"/Dew Indicator Light

Flashing of the Light indicates dew condensation on Camera/Recorder mechanism. While this Light is flashing, the unit will not operate. If this occurs, eject the tape and leave the power on. When the Light stops flashing, the unit can be operated.

### "POWER" ON/OFF Button

Press "POWER" ON/OFF Button to turn Camera/Recorder on. Press again to turn Camera/Recorder off.

"POWER" Light illuminates when "POWER" ON/OFF Button is pressed and Camera/Recorder is on.

### "STOP" Button

The "STOP" Button is used to stop playback, rewind, and fast forward operations. The "STOP" Button has no effect during record operation.

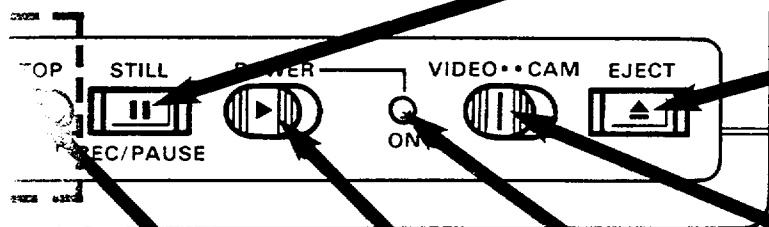

These Buttons are related to playback function and will not operate unless the "VIDEO/CAM" Select Switch is in the "VIDEO" position.

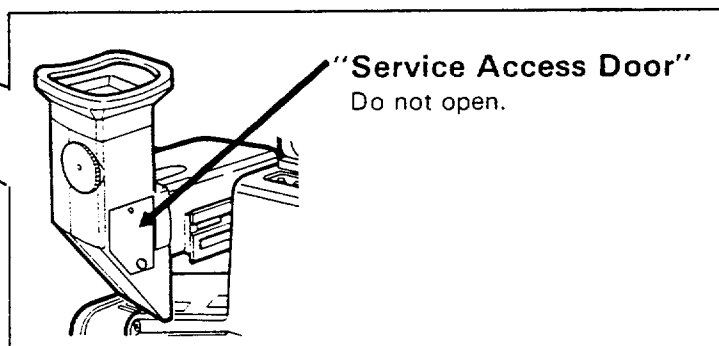

### Cassette Holder

Press "EJECT" Button to open the Cassette Holder. Be aware of the Cassette direction when inserting.

**NOTE:** Power source must be connected to open the Cassette Holder.

### "TRACKING" Control

Used when playing a tape recorded on another VCR. Adjust for best picture. At all other times leave it in the center position, which can be found as a small detent in the movement of the knob.

### "EAR"phone Jack

Sound being recorded by the microphone or played back may be monitored by attaching earphone to this jack.

### "DC IN 12V" Jack

Used for the optional Car Battery Cord which connects to the cigarette lighter socket in your car.

### Power Terminal Protection Cover

This Cover should be in the uppermost position covering the terminal at all times.

### "A/V OUT" Jack

Connect the Audio/Video Output Cable (Accessory No. 7) to this jack and to the audio and video inputs of your TV/monitor receiver. You may also connect the RF Converter Unit (Accessory No. 4) to this jack and your TV receiver.

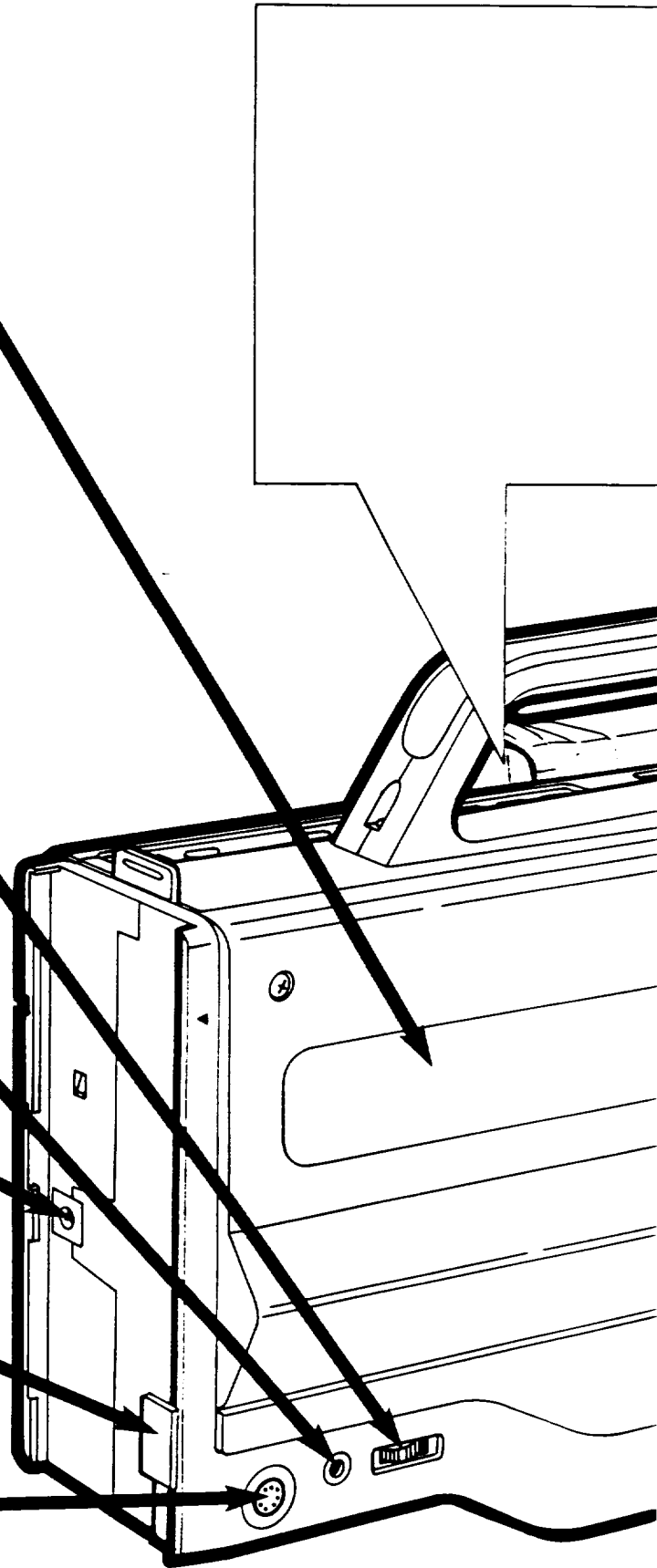

## Graphics in the Electronic Viewfinder

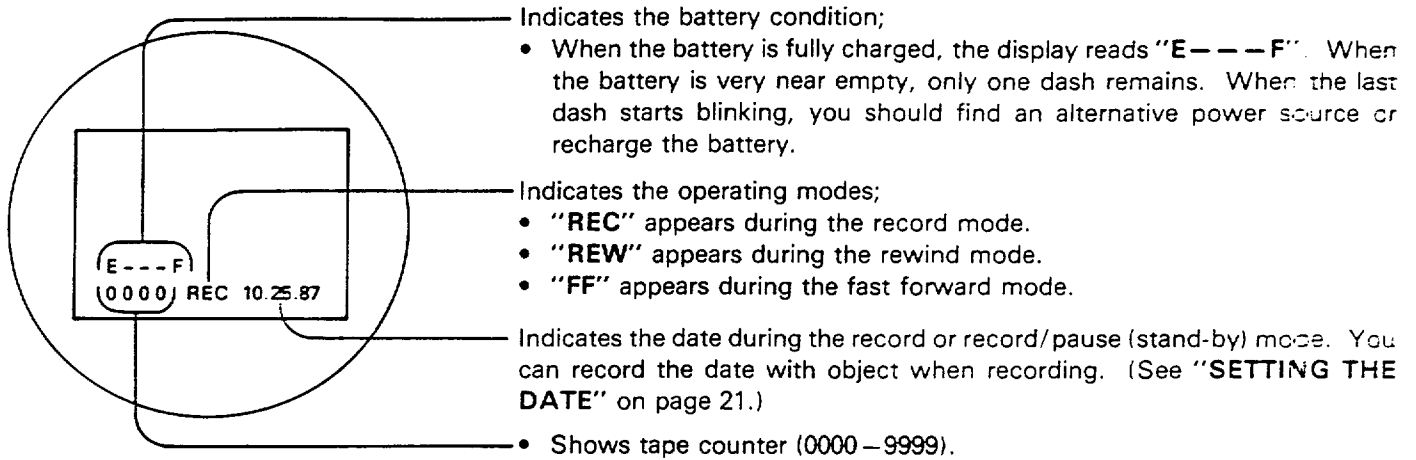

Indicates the battery condition;

- When the battery is fully charged, the display reads "E---F". When the battery is very near empty, only one dash remains. When the last dash starts blinking, you should find an alternative power source or recharge the battery.

Indicates the operating modes;

- "REC" appears during the record mode.
- "REW" appears during the rewind mode.
- "FF" appears during the fast forward mode.

Indicates the date during the record or record/pause (stand-by) mode. You can record the date with object when recording. (See "SETTING THE DATE" on page 21.)

- Shows tape counter (0000–9999).

### "MIC" Jack

Connect an external microphone (Not supplied here to record sound from the external microphone.

**NOTE:** Connecting an external microphone automatically switches off the built-in microphone.

### "MIC WIND/NORMAL" Switch

This switch is used to reduce noise that occurs due to wind. Place the Switch in the NORMAL position for normal use.

### Record Start/Stop Button

This Button is used to control the Camera/Recorder. When this Button is pressed with the Camera/Recorder set to the recording mode, the tape runs to start recording. "REC" indication appears in the viewfinder.

When this Button is pressed again, "REC" indication goes off and the tape stops and the Camera/Recorder enters the record/pause (stand-by) mode.

### Lens Cap Tab

Place the Lens Cap on this tab when you are ready to record a scene. The tab also prevents the Lens Cap from swinging around on its cord.

### Hand Strap

Adjust to best fit to your hand.

# USING THE AUTO FOCUS FEATURE

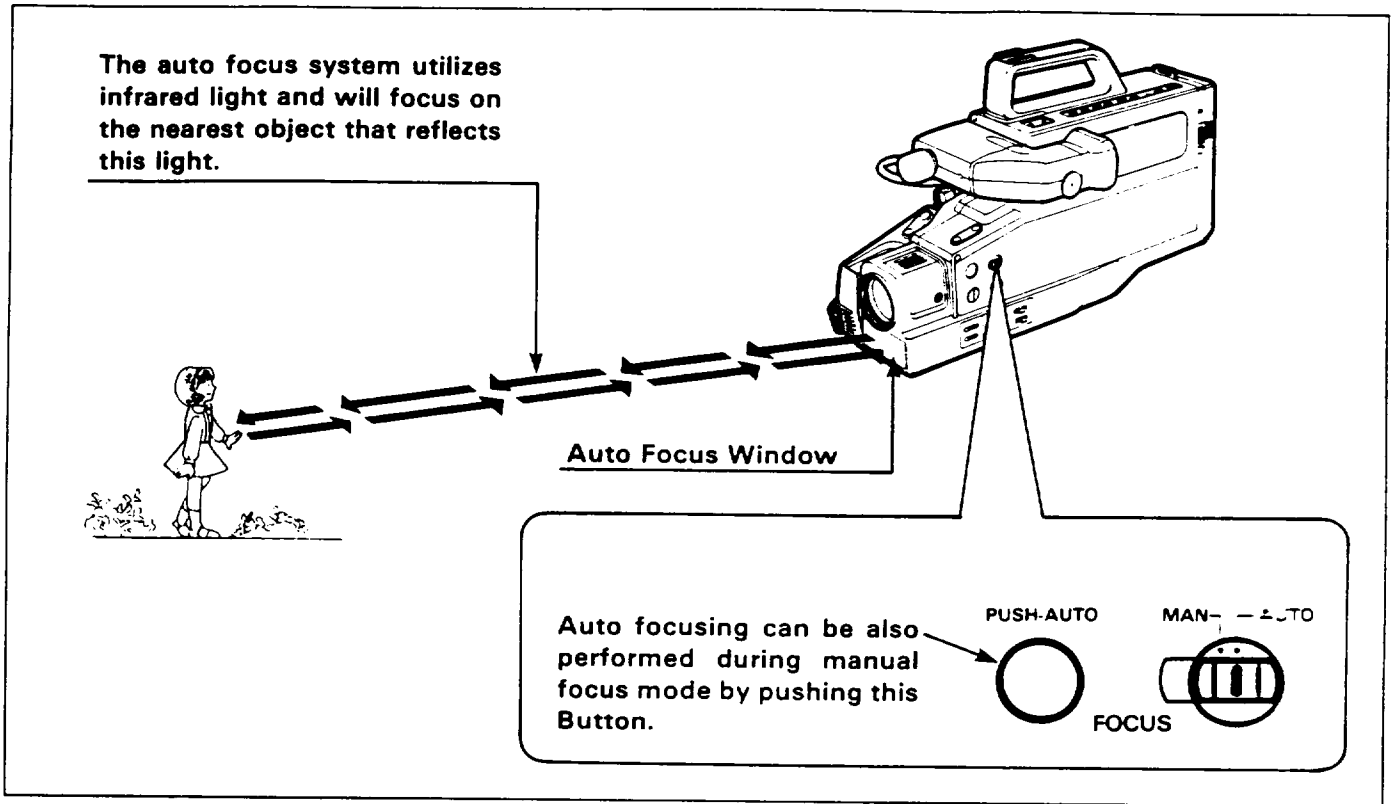

With the "FOCUS AUTO/MAN" Switch set to "AUTO" position, ordinary objects are automatically in optimum focus.

## ■ OBJECTS HARD TO AUTO FOCUS

The distance between the Auto Focus Window and the object is measured, and the Focus Ring is automatically turned for focusing. However, with the scenes such as shown below, the auto focusing may not operate properly, and manual focus must be performed. See next page.

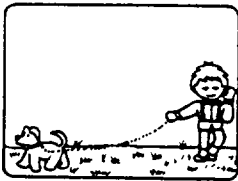

1. Object is not in the center.



2. Object in far and near positions at the same time.

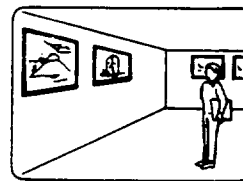

3. Object with continuous variation from far to near positions.

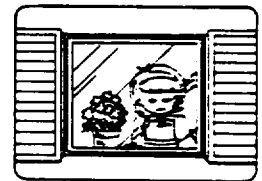

4. Object behind glass.

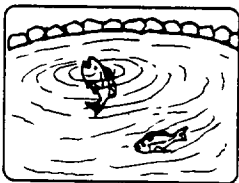

5. Black object or water which does not reflect infrared light.



6. Object always moving such as a crowd.



7. Object in the snow or fog.

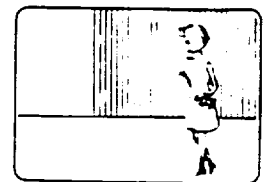

8. Objects with equal pitches.



## ■ MANUAL FOCUSING

1. Set "FOCUS AUTO/MAN" Switch to "MAN" position.
2. Zoom in on the object by pressing the Power Zoom Switch on the "T" side.

**NOTE:** See page 19 for "USING THE POWER ZOOM FEATURE".

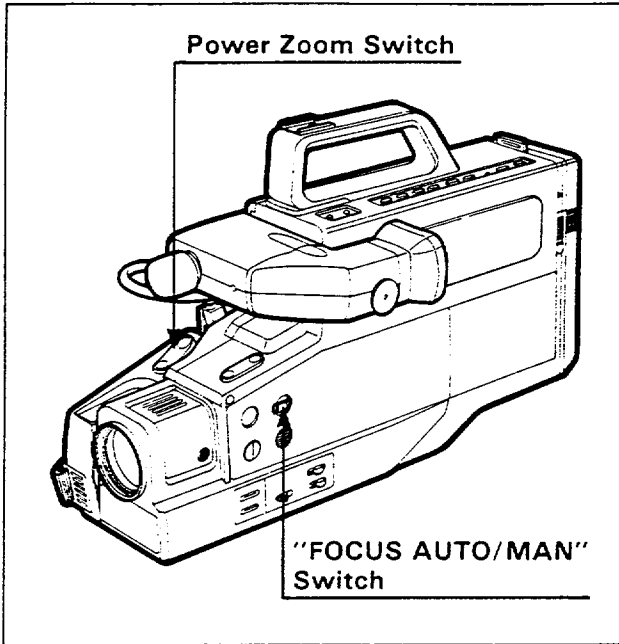

3. Focus on the object by pressing the Power Focus Switch.

**NOTE:** If focusing is performed without zooming up first, the picture may become out of focus when the zoom-in is done during actual picture taking.

4. Then, zoom out from the object as desired.

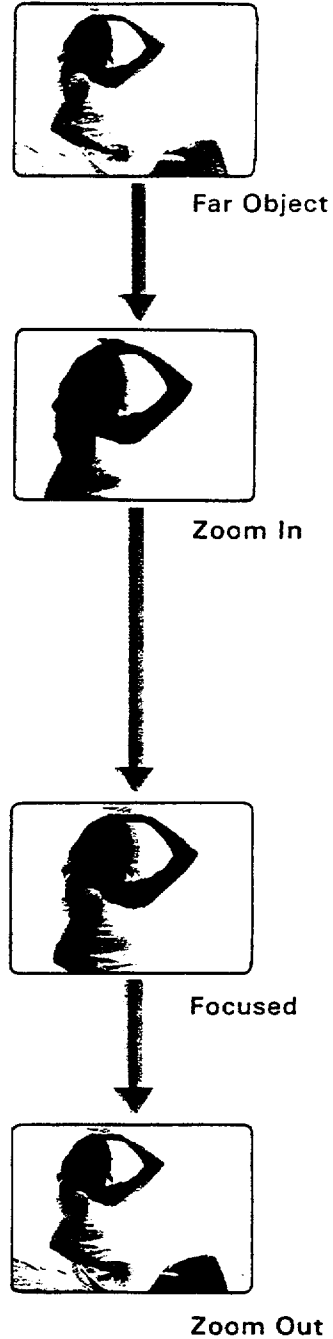
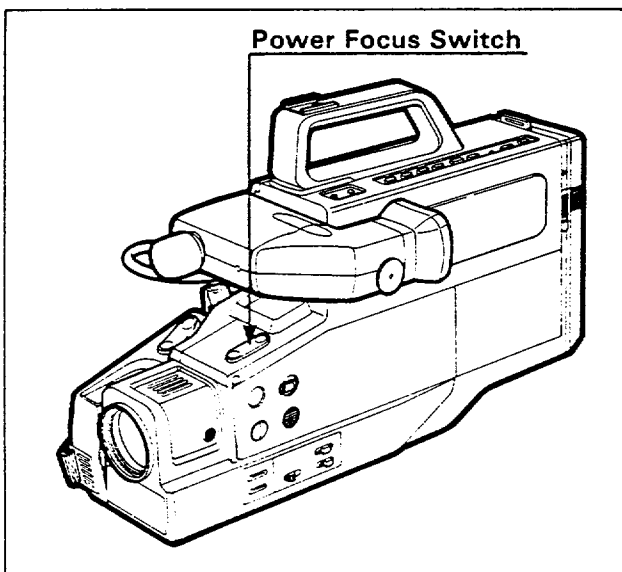

**NOTE:** The Auto focusing will not function if the lens is left in macro mode. To release it refer to Step 4 of "USING THE MACRO FEATURE" on page 19.

# USING THE SHUTTER SPEED CONTROL FEATURE

Use this feature to shoot tennis and golf shots that contain rapid movement. You can replay the still pictures at the crucial moments without any fluctuations.

When the "SHUTTER" Switch is set to "NORMAL", the shutter speed is 1/60 seconds. The speed can be changed up to 1/2000 seconds when the Switch is set to "SHUTTER".

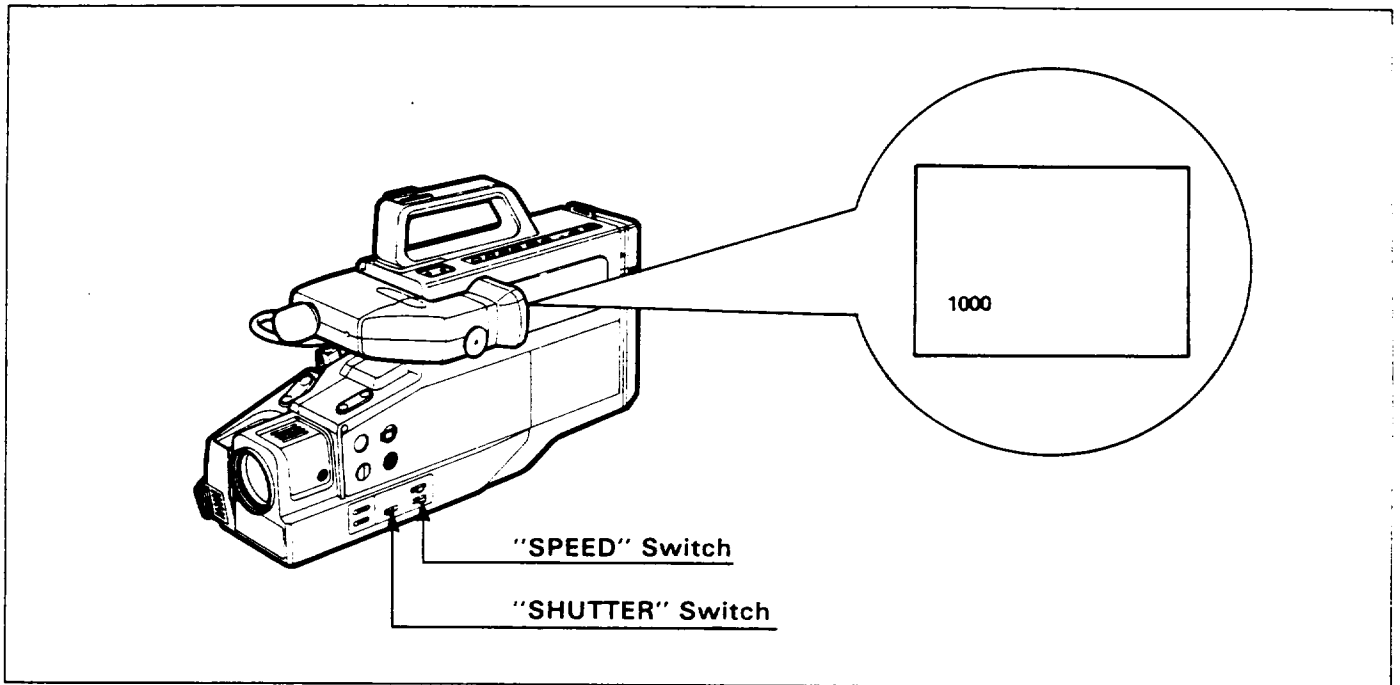

1. In record/pause (stand-by) or record mode, set "SHUTTER" Switch to "SHUTTER" and then press "SPEED" Switch as many times as may be required. The shutter speed will change 1/120 → 1/250 → 1/1000 to 1/2000 and then back to 1/120 seconds. The shutter speed is displayed in the Viewfinder.

For example, the speed is 1/1000 seconds, "1000" will be displayed.

#### NOTES:

- When "SHUTTER" Switch is set to "NORMAL", shutter speed is 1/60 seconds and "60" will not be displayed in the Viewfinder.
- When the 6-digit date display is displayed, the position in which the speed indication appears will be changed as shown in the figure.

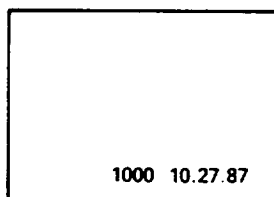

#### NOTES:

- Return "SHUTTER" Switch to "NORMAL" after recording is completed.
- When shooting at the 1/1000 or 1/2000 speed, more light is required because the pictures become darker than the normal shooting at 1/60 speed. When there is insufficient light, the speed indication flashes to warn you.
- When a tape that was recorded using the high speed shutter feature is played back, scenes changes will not be seen as a smooth motion.
- When the camera is pointed at an object that is moving rapidly, it may not be focused in the auto focus mode. In this case, focus manually.
- When recording with the illumination such as a fluorescent lamp, a mercury vapor lamp or a sodium lamp, the picture may become bright or dark (flickering).

2. Press Record Start/Stop or "STILL/REC/PAUSE" Button to start recording.

# USING THE SELF TIMER FEATURE

The Self Timer allows you to automatically start recording after about ten seconds.

Press **"SELF TIMER"** Switch **once** while in the record/pause mode.

The Camera/Recorder will automatically start recording after ten seconds when the Switch is pressed and will continue to record for approx. 30 seconds.

If you press the **"SELF TIMER"** Switch **twice**, the Camera/Recorder will automatically start recording after ten seconds when the Switch is pressed and then recording will continue until the Record Start/Stop Button or **"STILL/REC/PAUSE"** Button is pressed.

## NOTES:

- Record Indicator flashes for about 10 seconds to indicate self timer mode when you press **"SELF TIMER"** Switch and stays on during recording.
- Pressing **"SELF TIMER"** Switch a third time before recording starts releases the Self Timer mode.
- To stop the Camera/Recorder during Self Timer Recording, press Record Start/Stop Button or **"STILL/REC/PAUSE"** Button and the Camera/Recorder will enter the record/pause (stand-by) mode.
- The **"SELF TIMER"** Switch has no effect during normal recording.

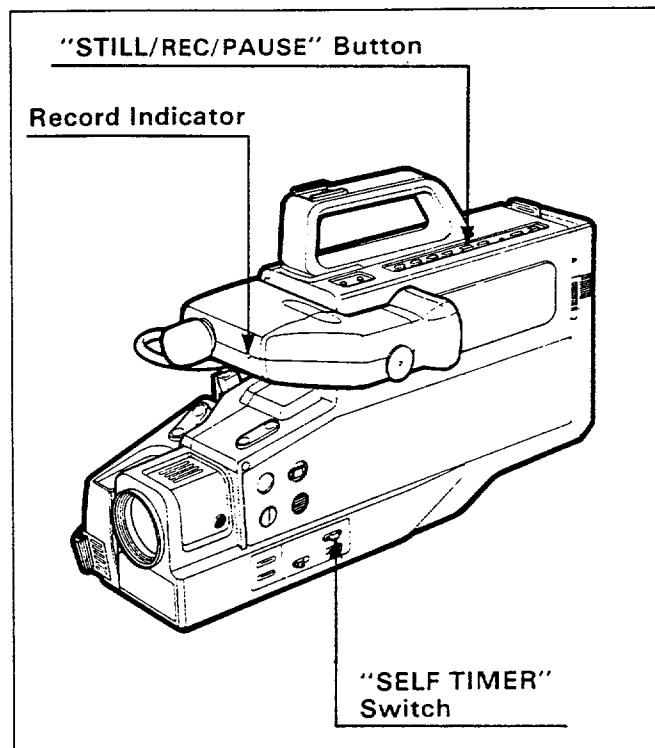

## USING THE POWER ZOOM FEATURE

- Press Power Zoom Switch on the "W" side, and the picture gradually widens.



- Press Power Zoom Switch on the "T" side, and the picture gradually becomes telescopic.

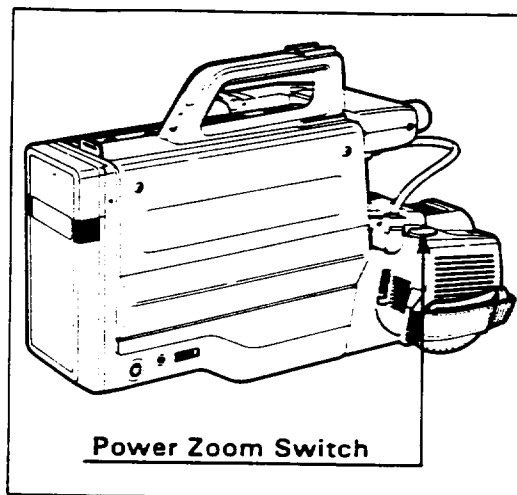

## USING THE MACRO FEATURE

Allows you to shoot objects as close as 1 cm from the lens tip.

1. Press and hold down Power Zoom Switch on the "W" side until it reaches the end, while viewing in the viewfinder.
2. Press "MACRO" Button and while holding it down, press Power Zoom Switch on the "W" side again to enter the MACRO mode.
3. Press Power Zoom Switch on "W" and "T" sides alternately for focusing.
4. To release the MACRO mode press and hold down Power Zoom Switch on the "T" side.

**NOTE:** Be sure to release the macro mode after using. If you fail to release the macro mode before returning to normal shooting, the pictures will be out of focus and Auto-Focus will not operate.

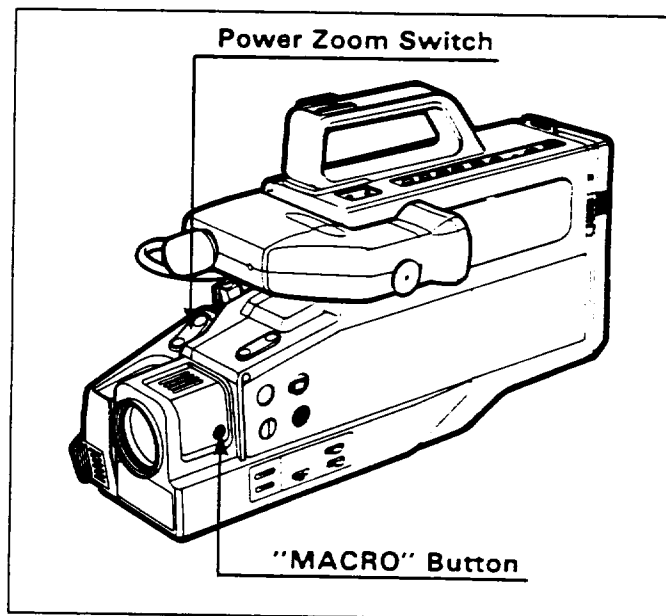

## USING THE INSTANT REVIEW FEATURE

1. In record/pause (stand-by) mode, press "REVIEW" Button, and the recorded scene of the last few seconds is played back in the reverse direction and then played back in the forward direction.
2. When the tape reaches the end of the scene you have just recorded, the Video Camera Recorder returns to the record/pause (stand-by) mode. Recording starts again when the Record Start/Stop Button is pressed again.

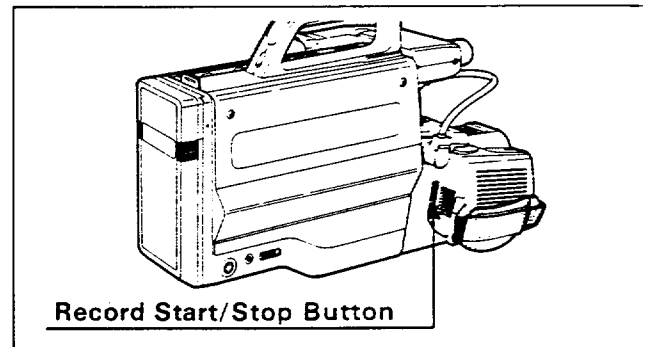
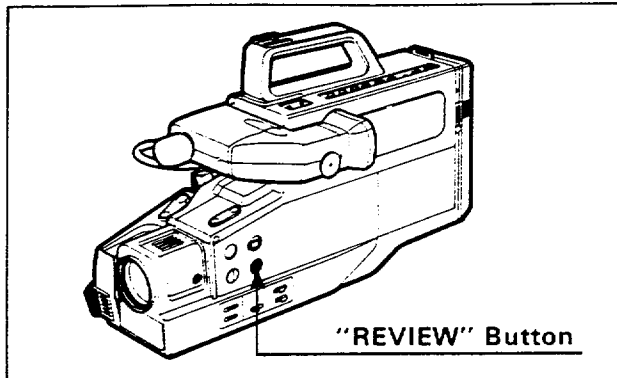

## USING THE AUTO IRIS FEATURE

This Camera/Recorder is provided with an auto iris mechanism which automatically adjusts the lens aperture in accordance with the incident light when the "IRIS" Control is placed in "AUTO" position. When the object is dark, the iris opens automatically, and it closes when the object is bright. When the power is switched off, the iris is automatically set to the fully closed position.

### ■ To manually adjust the iris

You can also adjust the iris manually.

- When the object is in bright light and the background is dark, adjust the "IRIS" Control counterclockwise to narrow the iris opening.
- When the background is in bright light and the object appears to be too dark, adjust "IRIS" Control clockwise to widen the iris opening.

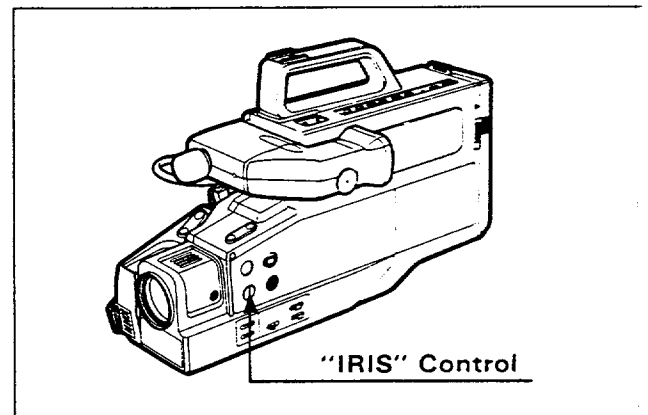

## USING THE FADE-IN/FADE-OUT FEATURE

Fade-in and fade-out are shooting techniques to soften the transition of the scenes from one to another. The fade-in causes the picture to start dark, gradually increasing in brightness. In the fade-out, the opposite takes place; a bright picture gradually darkens until it disappears completely.

### ■ FADE-IN

1. Turn "IRIS" Control fully counterclockwise before starting recording. The picture in the Electronic Viewfinder disappears.
2. Gradually turn "IRIS" Control to "AUTO" position after starting recording.

### ■ FADE-OUT

1. Set "IRIS" Control to "AUTO" position before starting recording.
2. Gradually turn "IRIS" Control fully counterclockwise after starting recording. The picture fades out.

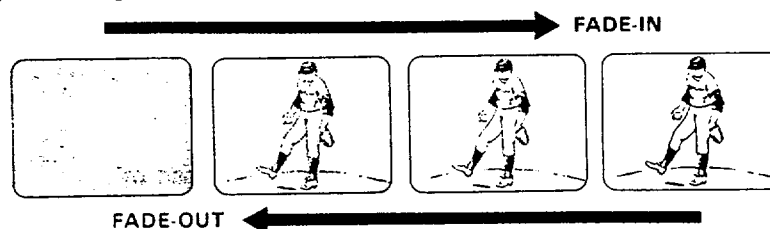

# SETTING THE DATE

This Video Camera/Recorder is capable of superimposing the calendar on the picture.

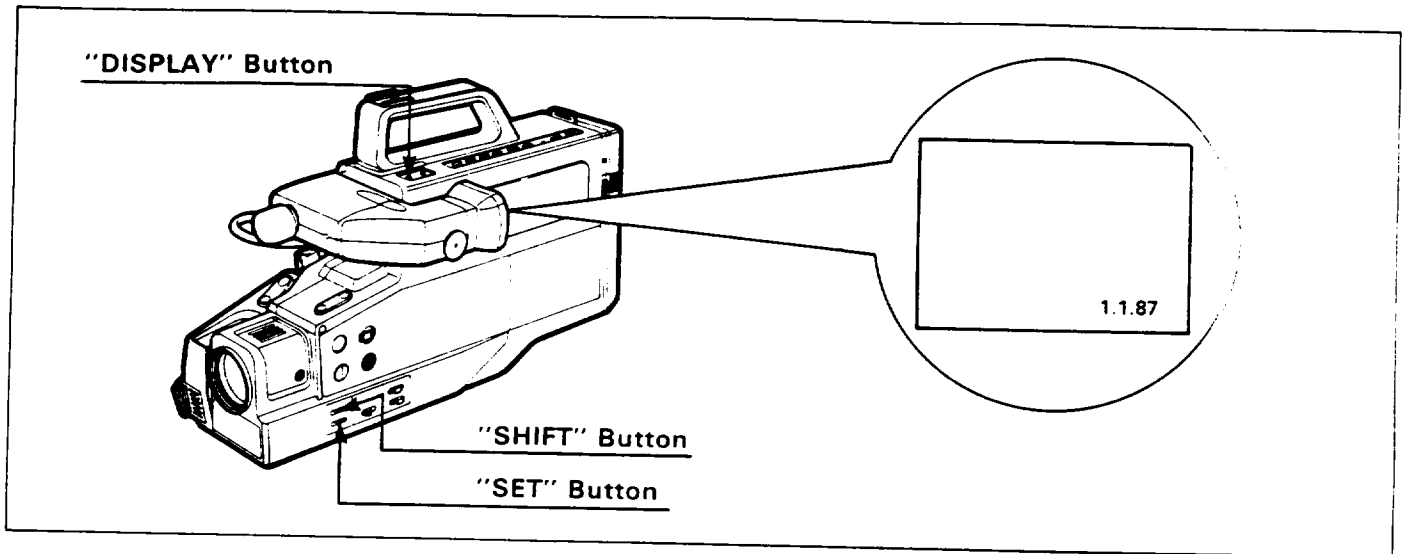

1. In record/pause (stand-by) mode, press **"DISPLAY"** Button once. The 6-digit date graphics appears in the Viewfinder.

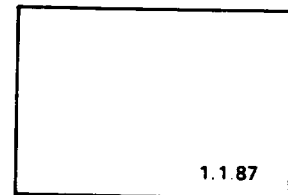

Set the date by pressing **"SHIFT"** and **"SET"** Buttons in order of month, day and year (for example 10.27.87 for October 27, 1987) as described below. The calendar is initialized on 1.1.87.

2. Press **"SHIFT"** Button once and the **"month"** flashes. Press **"SET"** Button to select correct month. Hold Button down to advance rapidly. When the correct month appears, press **"SHIFT"** Button.

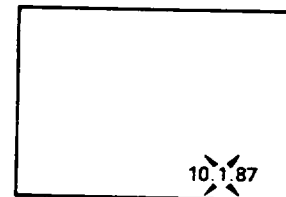

3. Press **"SET"** Button to select correct day. Hold Button down to advance rapidly. When the correct day appears, press **"SHIFT"** Button.

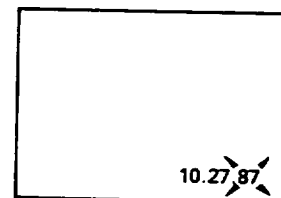

4. Press **"SET"** Button to select correct year. Hold Button down to advance rapidly. When the correct year appears, press **"SHIFT"** Button. Now the date has been set.

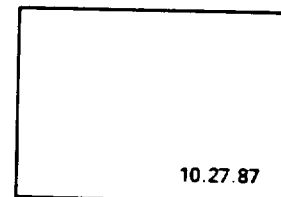

5. Press Record Start/Stop Button or **"STILL/REC/PAUSE"** Button to start recording. The date can be superimposed.

## NOTES:

- Set the date each time shooting takes place.
- The date will stay in the memory for about four hours after power is turned off.

# EYEPIECE ADJUSTMENT

To use the electronic viewfinder without eyeglasses on, adjust the Diopter Control for optimum focus adjustment.

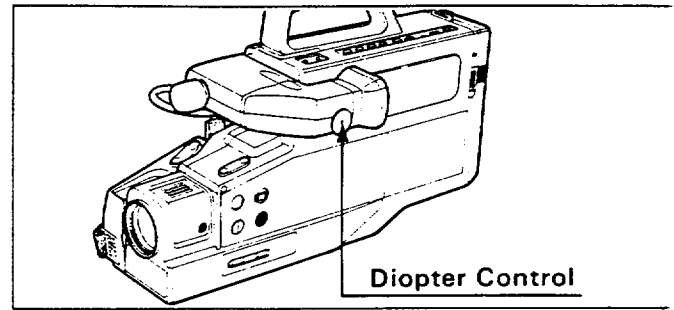

# PRODUCING BEST COLOR PROGRAM

**LIGHTING** — Lighting should be uniform from the top —

### Essential points on lighting people

1. A key light should be provided at the upper left in front of the person.
2. A weaker base light (spot) should be provided at the upper right and balanced with the key light. (Adjusting so that the left:right ratio is 2 : 1.5 by moving the lights backwards and forwards.)
3. Use one more light behind the subject. This emphasizes the person's head and shoulders and prevents the subject from being lost in the background.

**Caution:** Do not place lighting equipment near the Video Camera/Recorder as heat from the lighting equipment can cause the Video Camera/Recorder to malfunction.

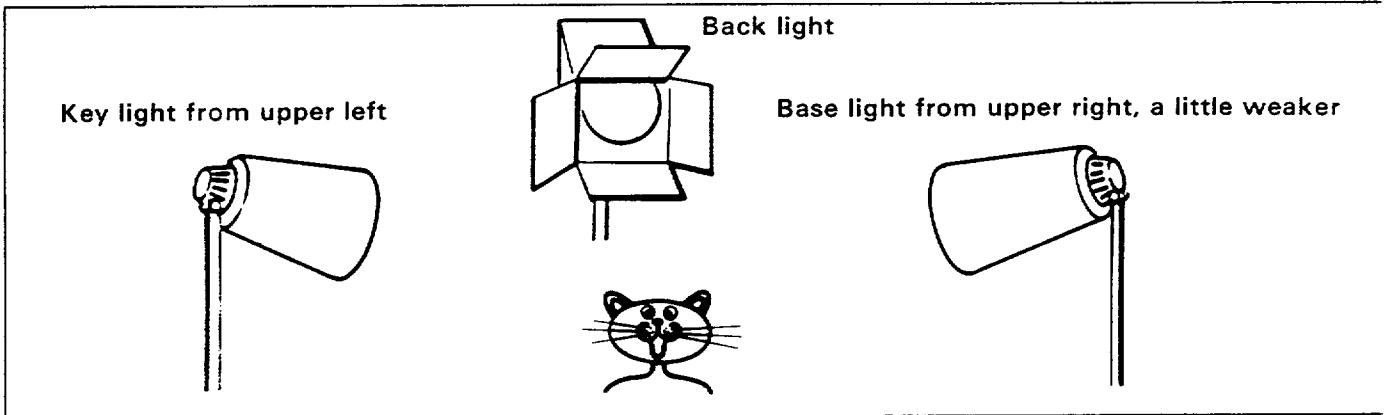

### Approximate brightness value (for reference only)

Unit: lux

Illumination of 500 to 100,000 lux is required for clearest pictures, though the camera can shoot an object in illumination of 7 to 100,000 lux. Increase illumination when object illumination is less than 500 lux. Install an ND (Neutral Density) filter (46 mm dia. and 0.75 mm pitch) on the lens if an object's illumination exceeds 100,000 lux.

10	<ul style="list-style-type: none"> <li>• Candle at 20 cm (10—15)</li> <li>• Cigarette lighter at 30 cm (15)</li> <li>• During intermission at a movie theater (15—35)</li> </ul>
100	<ul style="list-style-type: none"> <li>• Workshop in a machinery factory (150—200)</li> <li>• Arcade at night (150—200)</li> <li>• Flashlight at 1 meter (250)</li> <li>• Study desk with fluorescent lighting (400)</li> <li>• Office with fluorescent lighting (400—500)</li> <li>• Library reading room (400—500)</li> <li>• Bowling alley (500)</li> <li>• Sales floor of a department store (500—700)</li> </ul>
1,000	<ul style="list-style-type: none"> <li>• Clear day one hour before sunset (1,000)</li> <li>• Cloudy day one hour after sunrise (2,000)</li> </ul>
10,000	<ul style="list-style-type: none"> <li>• Cloudy day at 10 AM (25,000)</li> <li>• Cloudy day at noon (32,000)</li> <li>• Clear day at 3 PM (35,000)</li> <li>• Clear day at 10 AM (65,000)</li> </ul>
100,000	<ul style="list-style-type: none"> <li>• Clear day at noon (100,000)</li> </ul>

# CONNECTIONS AND OPERATIONS FOR VIEWING THE PICTURE PLAYED BACK ON YOUR TV

To play back a tape recorded on your Video Camera/Recorder and view it on your TV receiver, you must connect the Video Camera/Recorder to the TV receiver using either Audio/Video Output Cable (Accessory No. 7) or RF Converter Unit (Accessory No. 4).

You also may play back the tape recorded by your Video Camera/Recorder on any other VHS video cassette recorder. The Video Camera/Recorder records and plays back in VHS standard speed (SP). A tape recorded in long play (LP) or extra long play (EP) cannot be played back on this Video Camera/Recorder.

**Example 1: If your TV is a regular TV,**

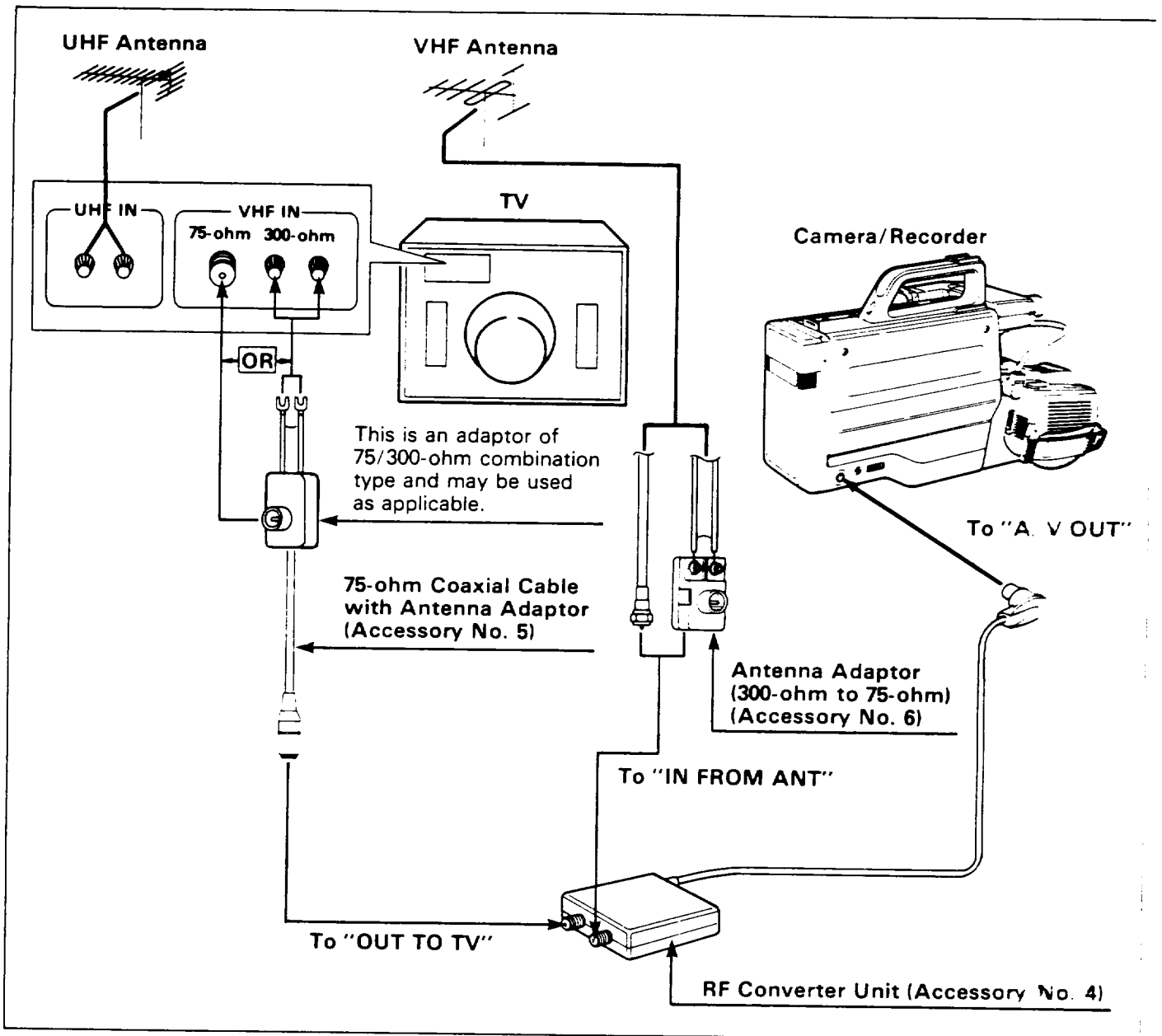

1. Disconnect the VHF antenna leads from the rear of the TV receiver.

**NOTE:** Leave the UHF antenna leads connected to the TV.

2. Connect the VHF antenna lead to "IN FROM ANT" on the RF Converter Unit (Accessory No. 4). If the cable is round (75-ohm), it will connect directly to the "IN FROM ANT". If it is the flat type (300-ohm), connect it to the Antenna Adaptor (300-ohm to 75-ohm) (Accessory No. 6) and slip the Adaptor on to the "IN FROM ANT" terminal.



3. Connect the 75-ohm Coaxial Cable with Antenna Adaptor (Accessory No. 5) to "OUT TO TV" on the RF Converter Unit.
4. Connect the other end to the VHF antenna terminal on the TV, as illustrated.
5. Connect the Connector Cable from RF Converter Unit to "A/V OUT" jack on the Video Camera/Recorder.
6. Turn on the TV and set to Channel 3 unless Channel 3 is one of the TV stations in your area. If Channel 3 is used in your area, set your TV to Channel 4.
7. Set the RF Channel Selector on the RF Converter Unit to "CH3" or "CH4" to match the channel selector on your TV. This is the Video Camera/Recorder channel on your TV set. Your TV receiver must be tuned to this channel any time a video cassette is played back on the Video Camera/Recorder.

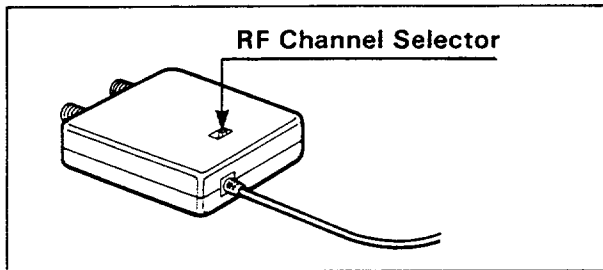

8. Press "EJECT" Button on the Video Camera/Recorder and then insert the cassette.

9. Set "VIDEO/CAM" Select Switch to "VIDEO" position.
10. Press "POWER" ON/OFF Button on.
11. Press "PLAY" Button.
12. After playing press "STOP" Button.

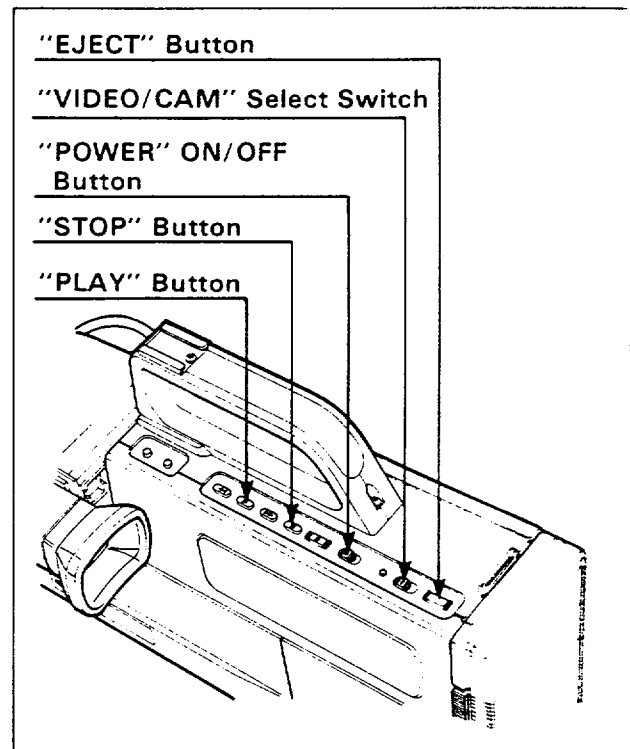

**NOTE:** If you want to watch a TV program with Video Camera/Recorder connected as illustrated, press "POWER" ON/OFF Button of the Video Camera/Recorder off, or disconnect the connector cable of RF Converter Unit from "A/V OUT" jack on the Video Camera/Recorder.

**Example 2:** If your TV has "VIDEO IN" and "AUDIO IN" jacks,

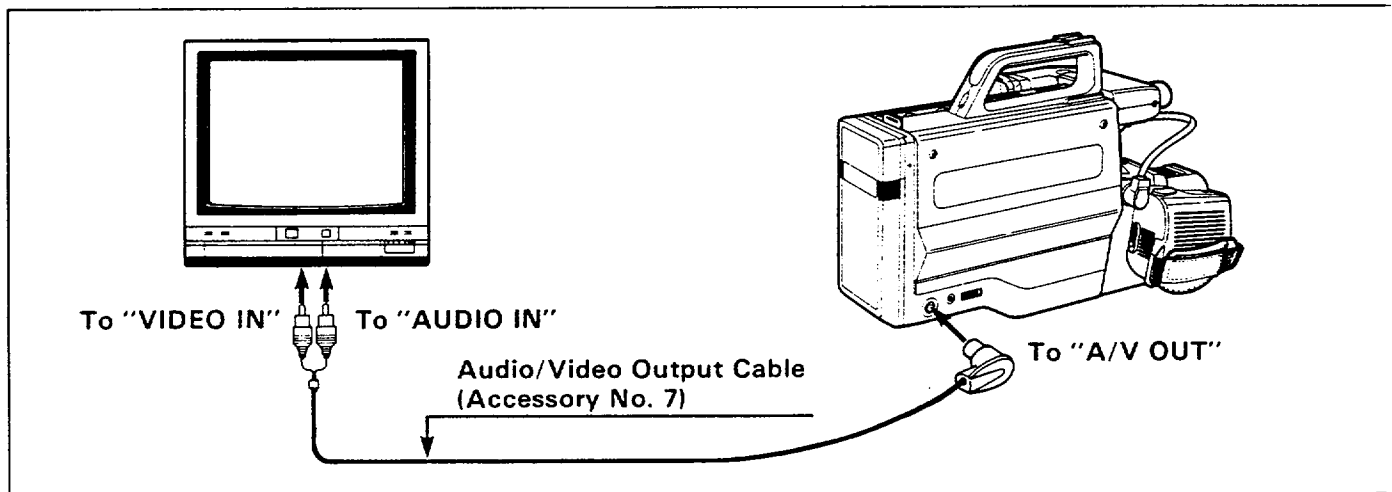

1. Connect the Audio/Video Output Cable (Accessory No. 7) to "AUDIO IN" and "VIDEO IN" of your TV.
2. Connect the other end of the Audio/Video Output Cable to "A/V OUT" of your Video Camera/Recorder.
3. Turn on TV.
4. Perform same procedures in Steps 8 through 12 of "Example 1" above.

# CONNECTIONS AND OPERATIONS FOR RECORDING TV PROGRAM

If your TV has audio/video out jacks, you can record the TV program with Camera/Recorder.

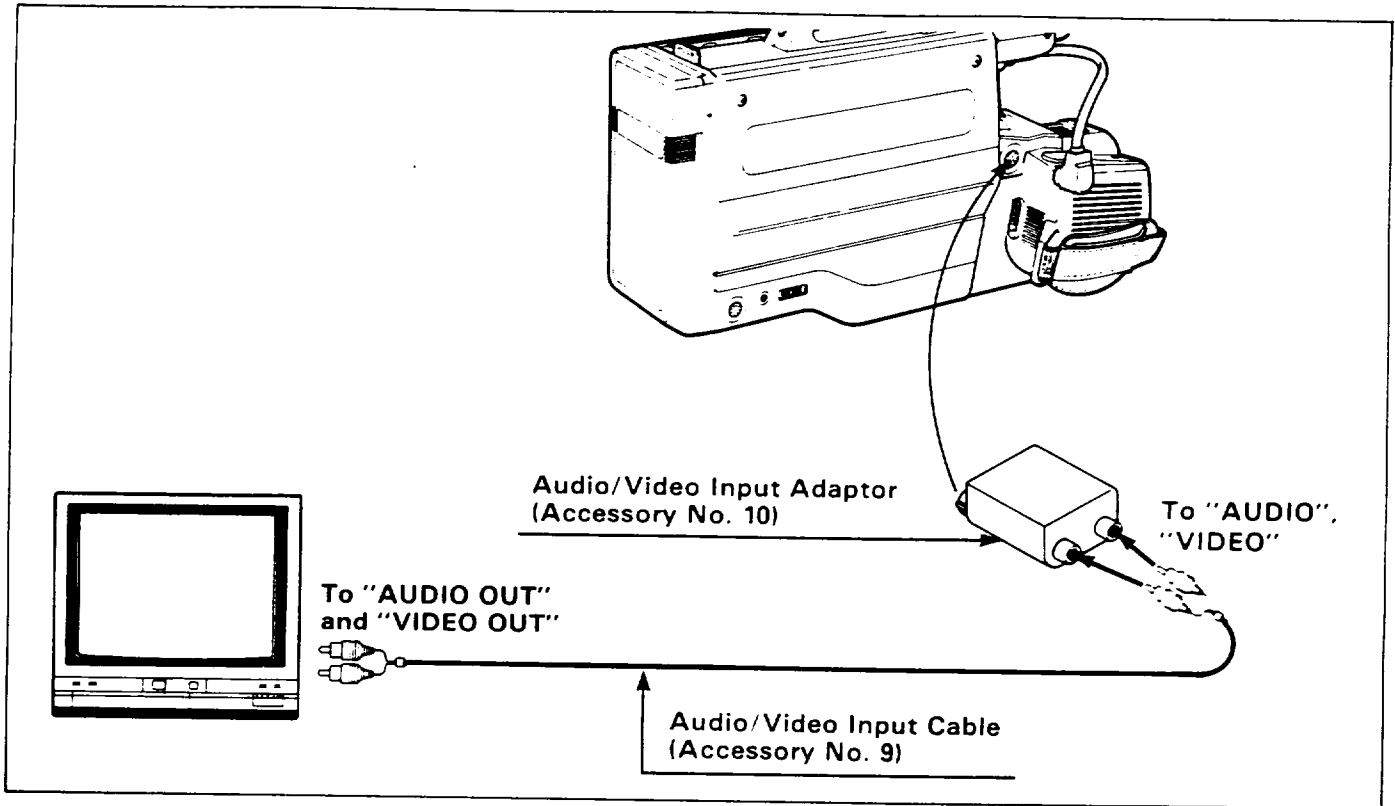

1. Remove the cable of the Electronic Viewfinder from the Video Camera/Recorder.
  2. Plug Audio/Video Input Adaptor to Video Camera/Recorder.
  3. Connect Audio/Video Input Cable (Accessory No. 9) to "AUDIO" and "VIDEO" of the Audio/Video Input Adaptor (Accessory No. 10). Connect the other ends to "AUDIO OUT" and "VIDEO OUT" of your TV respectively.
  4. Press "EJECT" Button and insert the cassette.
- NOTE:** Power source must be connected to the Video Camera/Recorder.
5. Set "VIDEO/CAM" Select Switch to "CAM".
  6. Press "POWER" ON/OFF Button on.
  7. Press Record Start/Stop Button to start recording. You are now recording the program you see on your TV screen.

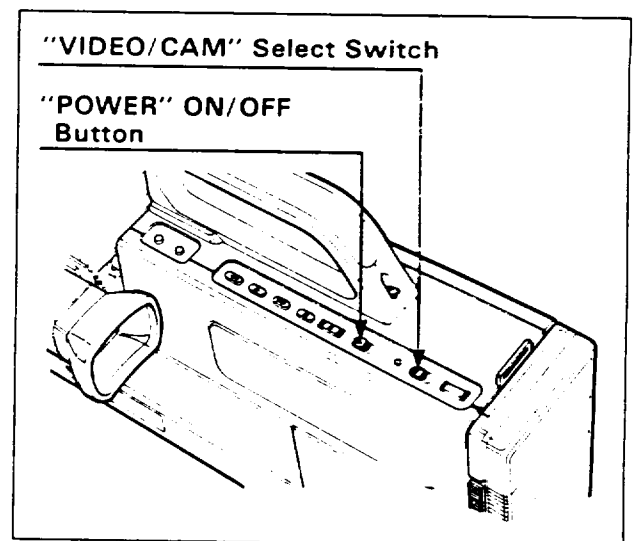
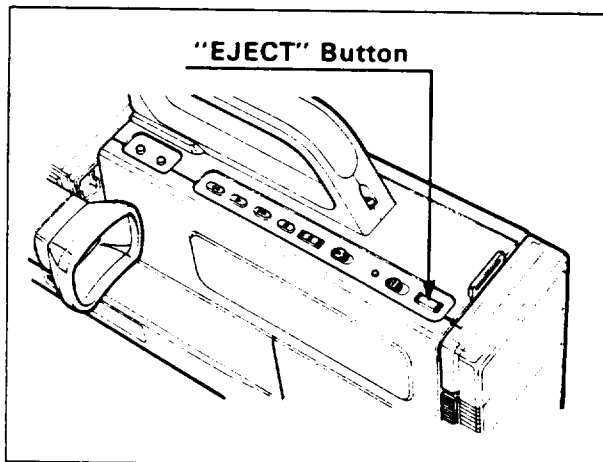

8. Press Record Start/Stop Button once again to stop recording.

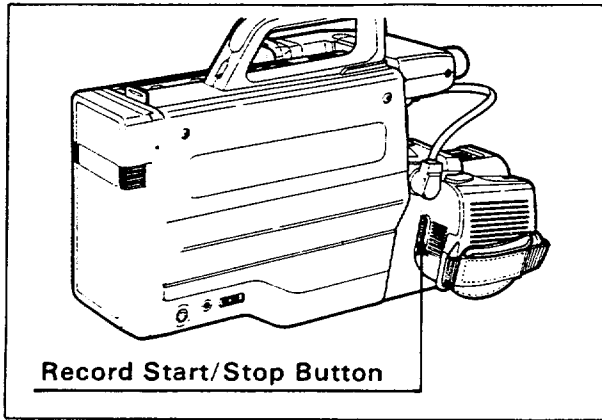

9. After recording, set "VIDEO/CAM" Select Switch to "VIDEO", and the Video Camera/Recorder will be now in the stop mode.
10. Press "POWER" ON/OFF Button off and then "EJECT" Button to remove the cassette.

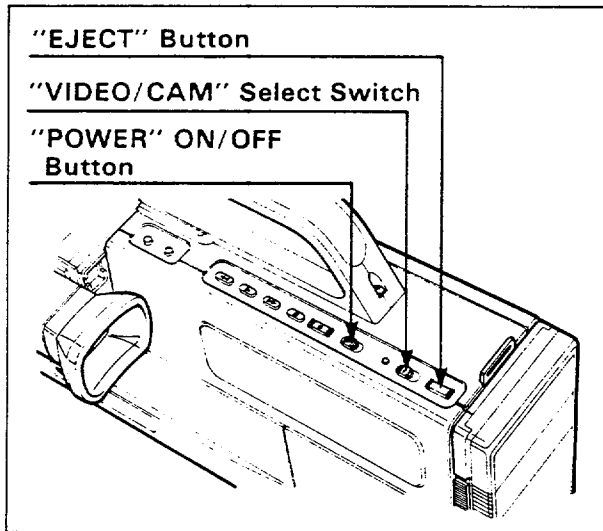

11. Remove the Power Source from the Video Camera/Recorder.

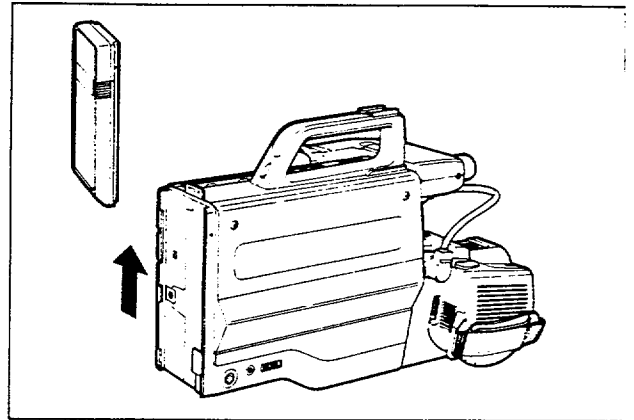

**NOTES:**

- Always be sure to remove the Power Source after using the camera.
- Setting the date when recording a TV program allows the date to be superimposed in the picture.
- When recording from external source through the AV input jack (viewfinder jack), disregard shutter speed indication on screen. Recording from external source is always done at the 1/30 second shutter speed even if the "SHUTTER" Switch is set to "SHUTTER".

## USING THE F-SEARCH AND R-SEARCH FEATURES

When you press "F.FWD" or "REW" Button during playback, the tape will be played back at a speed about 3 times faster than the normal playback speed, and you can easily locate a certain spot on the tape.

**NOTE:** There will be some noise (interference) in the F-search or R-search pictures.

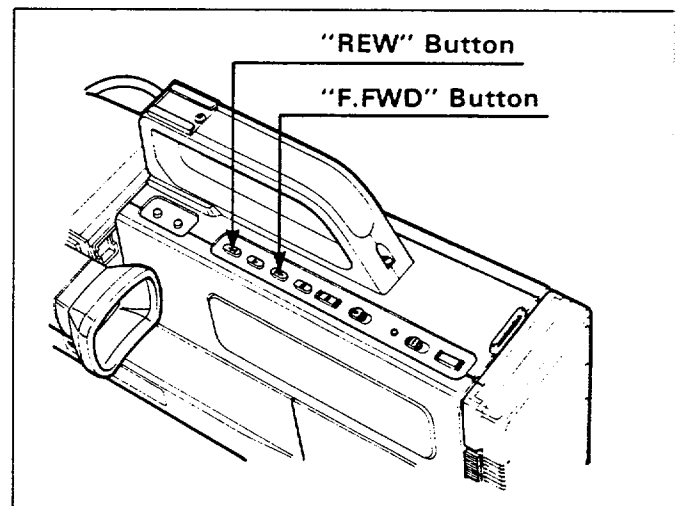

## USING THE STILL FEATURE

When "STILL" Button is pressed during playback, a still picture can be seen. To start again press "STILL" Button and playback will be resumed.

**NOTE:** There will be some noise (interference) in the still picture.

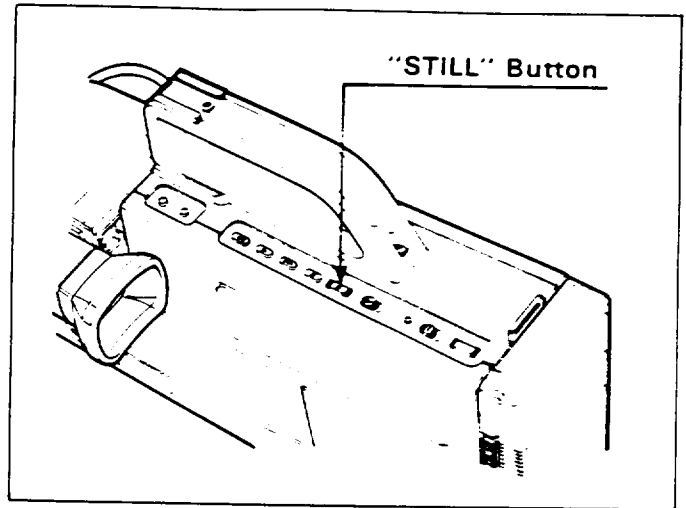

## USING THE MEMORY FEATURE

When the tape counter indication appears in the viewfinder, a tape that is being rewound automatically stops when the Counter reads approximately "0000". This is useful if there is a section of tape you want to review immediately after recording or if you want to return to the same point several times in a row.

1. Press "DISPLAY" Button. (The 4-digit tape counter appears in the viewfinder.)
2. Start playing or recording a tape.
3. At the point you want playback to start, press "RESET" Button to reset the Counter to "0000".
4. Continue to play or record.
5. Press "STOP" Button.
6. Press "REW" Button. The tape will be rewound to the preselected point, at approximately "0000" indication.

**NOTE:** The tape will also stop approximately at "0000" during fast forward mode.

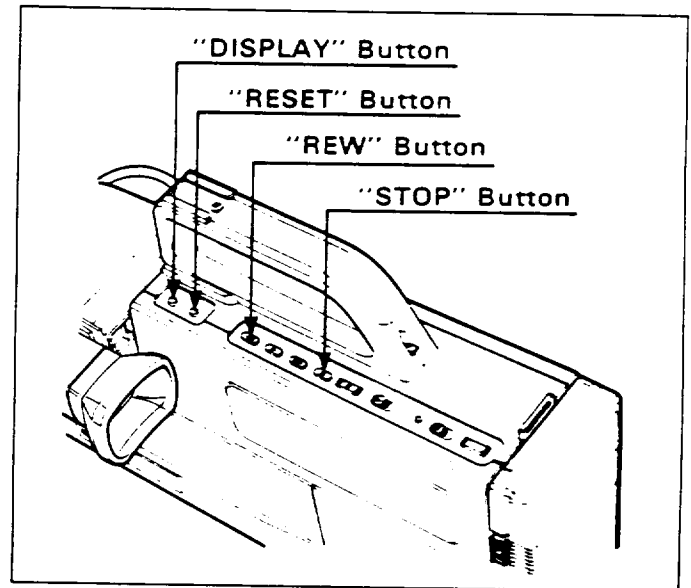

## OPERATING HINTS.....

- \* After you have finished using the Camera/Recorder, remove the cassette and the power source from the Camera/Recorder and attach the Lens Cap.
- \* Always reset the "COUNTER" to "0000" when starting to use a cassette. Make a note on the cassette what number the "COUNTER" reads when the recording is finished if less than the full cassette is used. This allows you to record more program materials at the end of the first recording. Any other locations on the tape can be noted on the cassette label also, if desired, so you can quickly locate them later.

# CAMERA/RECORDER TO VTR DUBBING

If you wish to exchange or copy some of your friend's favorite home recordings, the following instructions can be used to connect Video Camera/Recorder to VTR for this purpose.

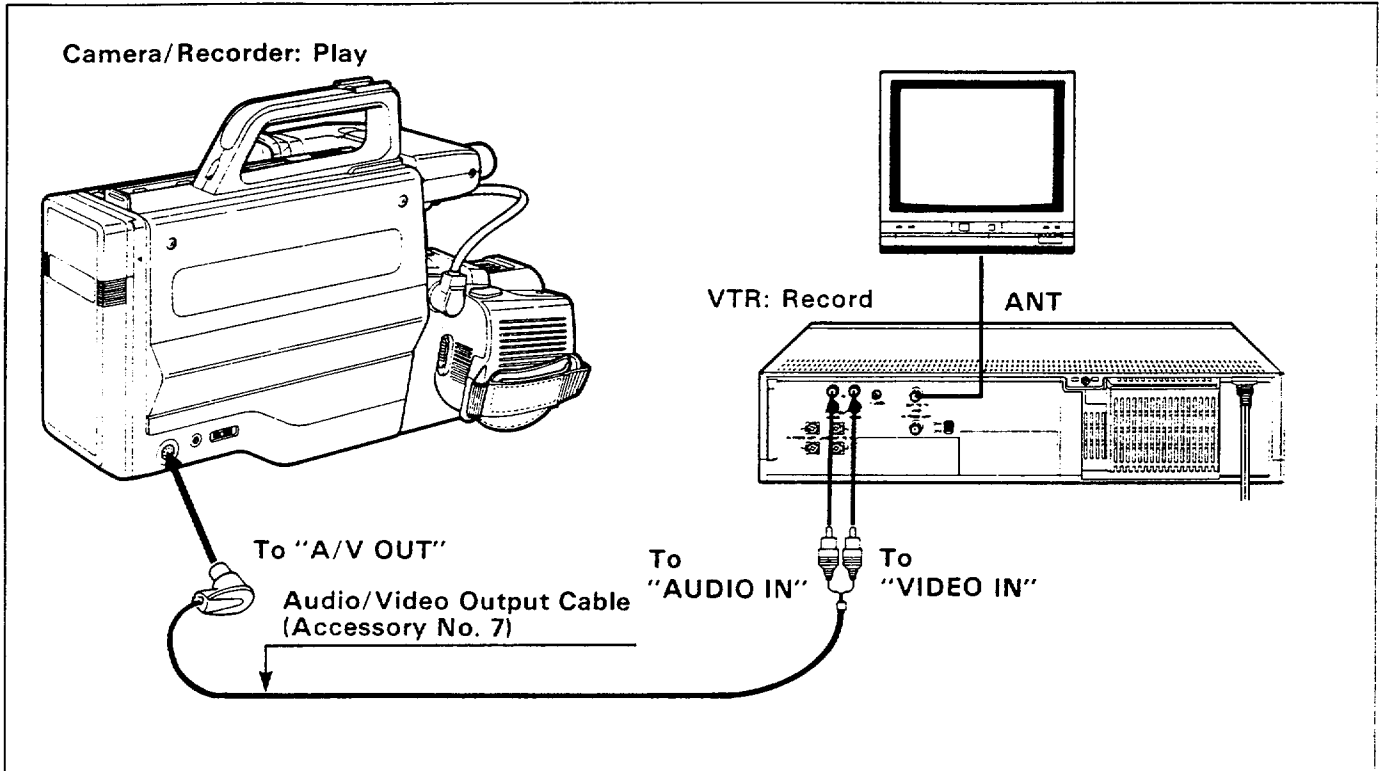

1. Connect the Audio/Video Output Cable (Accessory No. 7) to "A/V OUT" of your Camera/Recorder.
2. Connect the other ends to "AUDIO IN", "VIDEO IN" respectively.
3. Play the tape on the Camera/Recorder and record it on the VTR.

**NOTE:** If you connect the "VHF OUT TO TV" connector of VTR to the "TV ANT" connector, as illustrated and set "VTR/TV" Selector of the VTR to "VTR" mode, the picture being dubbed by VTR can be monitored.

## TAPE COUNTER DIGIT/MINUTE CHART (APPROX. FIGURES)

Minute \ Tape	Tape		
	T-60	T-120	T-160
30	1130	2110	2210
60 (1 hour)	2110	3530	3760
90		4690	5020
120 (2 hours)		5680	6120
150			7100

# TROUBLESHOOTING

Your Video Camera/Recorder is a highly sophisticated instrument. It has been carefully checked and adjusted at the factory under the most rigid quality control and inspection systems. However, should problems develop, check the following points and take necessary corrective measures.

## INSERTING OR REMOVING THE CASSETTE

Symptom	Check Point & Correction
Cassette Holder cannot be opened when you press "EJECT" Button.	* Connect the Power Source.
Cassette cannot be inserted into Cassette Compartment.	* Load cassette in direction indicated by arrow on cassette.
	* Cassette window must be toward outside.

## CAMERA RECORDING

Symptom	Check Point & Correction
Picture does not appear in the Viewfinder.	* Remove the Lens Cap
	* Press "POWER" ON OFF Button on
	* Plug the connector cable from Electronic Viewfinder to the Jack of Camera Recorder
	* Set "VIDEO/CAM" Select Switch to "CAM" position.
The Camera/Recorder will not go into the recording mode, even when Record Start/Stop Button is pressed.	* Set "IRIS" Control to "AUTO" position
	* The cassette has had the erase prevention tab removed. Stick a piece of cellophane tape over the erase prevention hole or select a different cassette.
Picture is out of focus. Auto-Focus does not operate.	* Set "VIDEO/CAM" Select Switch to "CAM" position.
	* Set "FOCUS AUTO/MAN" Switch to "AUTO". * The Video Camera Recorder is set to <b>MACRO</b> mode. Press and hold down Power Zoom Switch on the "T" side to release "MACRO" mode and then focus on the object.

## RECORDING TV PROGRAMS OFF THE AIR

Symptom	Check Point & Correction
The Camera/Recorder will not go into the recording mode, even when Record Start/Stop Button is pressed.	* The cassette has had the erase prevention tab removed. Stick a piece of cellophane tape over erase prevention tab hole or select a different cassette.
	* Set "VIDEO/CAM" Select Switch to "CAM" position.

## PLAYBACK OF PRE-RECORDED CASSETTE

Symptom	Check Point & Correction
"PLAY" Button cannot be engaged.	* Set "VIDEO/CAM" Select Switch to "VIDEO" position.
No picture appears on television screen when "PLAY" Button is pressed. (TV is connected to the Camera/Recorder by using RF Converter Unit.)	* Set the television to the Camera Recorder channel (3 or 4) depending upon the selected channel on the RF Channel Select Switch of RF Converter Unit.
Interference on playback picture.	* Adjust "TRACKING" Control.
	* When you see the playback picture on your TV, adjust fine tuning knob on television set to obtain best picture.
	* The pre-recorded tape is EP or LP recording. This Camera/Recorder is for use in SP recording only.
Picture bends at the top of TV screen.	* TV receiver is of older type. It needs to be modified to work properly with Camera/Recorder.
	* Tape is damaged. Try another cassette.
Color of your TV screen is too bright, too faint or change.	* TV set has VIR circuit. Turn it off during playback.

## DEW LIGHT

Symptom	Check Point & Correction
"DEW (POWER)" Light flashes.	* Condensation on the Camera/Recorder mechanism — wait until the Unit has reached normal room temperature, and condensation has dried. "DEW (POWER)" Light will then stop flashing.

## BATTERY CONDITION

Symptom	Check Point & Correction
The "E" indication in the Electronic Viewfinder flashes to indicate Battery is discharged.	* Try another Battery or charge the Battery.

# HEAD CLEANING

- Picture playback may become blurred or be interrupted. This does not mean that the recorded program has been erased.
- Dirt accumulated on the head after long periods of use causes this problem. In this case, head cleaning requiring highly technical care is necessary.
- For head cleaning consult the nearest dealer or VTR Service Center for recommendations.

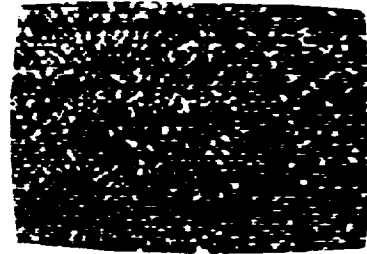

## PERIODIC MAINTENANCE

The Video Camera/Recorder is a precision electromechanical device which will require periodic maintenance after a period of normal use. We expect that no maintenance other than head cleaning will be required during the warranty period by most users, unless the Video Camera/Recorder is heavily used or seldom used. Normal maintenance is the responsibility of the user, although defective parts are covered during the warranty period. Consult your VTR Service Center to determine recommendations for normal maintenance based on your location, use patterns and machine age.

## SPECIFICATIONS

### ■ General

Power requirements	12V DC
Power consumption	9.5 watts (When "FOCUS AUTO/MAN" Switch to "MAN".)
Dimensions	4-5/8"(W) x 9-1/16"(H) x 13-11/16"(D) 117(W) x 230(H) x 348(D) mm
Weight	4.4 lbs (2.0 kg)

### ■ Video Recorder Section

Format	VHS
Record/playback system	Four video record/playback heads
Video signal	EIA standard NTSC color
Tape speed	33.35 mm/sec.
Video input	1.0 Vp-p, 75 ohm
Video output	1.0 Vp-p, 75 ohm
Audio input	-7.8 dBs (316 m Vrms), more than 47K ohms
Audio output	-7.8 dBs (316 m Vrms), less than 1K ohm
Fast forward/rewind time	Less than 10 minutes with T-160 cassette

### ■ Camera Section

Scanning	525 lines/60 fields/30 frames
Required minimum illumination	7 lux
Pickup device	2/3" Solid state MOS Imager
Lens diameter	46 mm

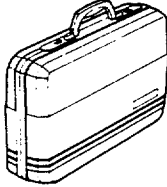
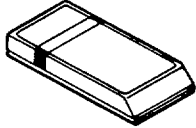
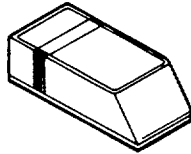
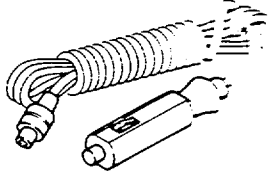

# OPTIONAL ACCESSORIES

<b>Carrying Case PV-Z67A</b>	<b>Battery Pack (1 hour type) PV-BT11</b>	<b>Battery Pack (2 hour type) PV-BT12</b>	<b>Car Battery Cord PC-YC12</b>
			

# **PENTAX**

**PENTAX CORPORATION.** 35 Inverness Drive East Englewood, CO 80112  
Service information : (303) 799-8000

**PENTAX CORPORATION.** 1101 Stewart Ave. Garden City, NY 11530  
Service information : (516) 222-0830

**PENTAX CORPORATION.** 350 East Devon Ave. Itasca, IL 60143  
Service information : (312) 250-9000

**PENTAX CORPORATION.** 8363 Reseda Blvd. Northridge, CA 91324  
Service information : (818) 701-5080