

PENTAX

8 mm VIDEO CAMERA/RECORDER

PV-C840E

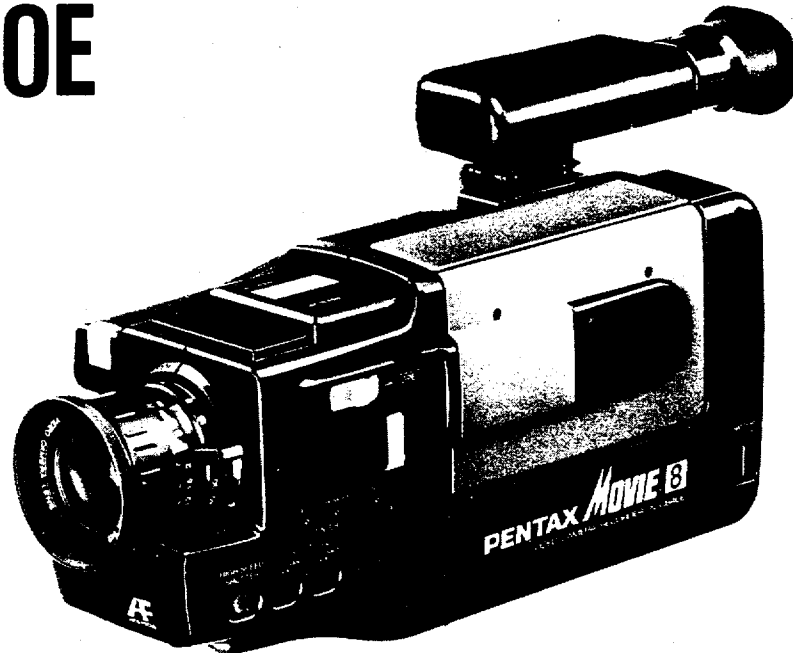

INSTRUCTION MANUAL

English **GE**

BEDIENUNGSANLEITUNG

Deutsch **D**

MODE D'EMPLOI

Français **F**

MANUAL DE INSTRUCCIONES

Español **E**

HANDLEIDING

Nederlands **NL**

MANUALE D'USO

Italiano **I**

BRUKSANVISNING

Svenska **SV**

PENTAX *MOVIE* 8

Congratulations on buying the Video Camera/Recorder. For maximum pleasure and convenience please read these simple instructions before operating your Camera/Recorder

RECORDING AND PLAYBACK

- This is an 8 mm VIDEO CAMERA/RECORDER. Use 8 mm video cassettes only.
- Recording speed in SP mode is 20.051 mm/second.
- You may not be able to play certain foreign-made video cassettes on this Video Camera/Recorder because of different TV broadcasting systems. Check to make sure that the cassette tape was recorded on an PAL system.

WARNING: Many television programs are copyrighted. One court has held that private, noncommercial, in-home video taping of copyrighted televised programs constitutes copyright infringement. Purchasers are advised not to copy such programs

Contents

Features	1
Precautions	1
Accessories	2
Parts Name	3
Preparations	5
Camera Recording	11
Playback	14
Recording Review	16
Zoom	16
Macro (close-up)	17
Lens Aperture	18
Auto Focusing	18
High Speed Shutter	19
Date Imprint	20
Tape Counter Operation	23
Connections	24
Important Notes	26
Before Requesting Service	28
Specifications	30
Holding The Camera	31
Basic Shots	32
Panning/Tilting	33
Zooming	34
Lighting Conditions and Lights	34
The Personal Touch	36

Features

- Integrated camera/8mm video recorder
- Automatic focus
- Automatic white balance with WHITE SENSOR
- Date imprint
- Macro (close-up) recording
- Six-power zoom-in/zoom-out — powered or manual operation
- Electronic viewfinder for immediate playback
- Recording review for checking the last part of recording
- Still frame/picture search
- Memory counter
- Maximum 90minutes recording

Precautions

■ No water, dust or sand

Be careful that no water, dust or sand enters the Camera/Recorder because it may cause trouble and accidents.

- Never point the lens at the sun or any other strong light. Do not shoot excessively bright objects for a long time to prevent damage to the pickup device. When you are not using the Camera/Recorder, switch off its power and attach the lens cap.

- Be sure not to leave it in a place at high temperature exceeding 60 °C, or the pickup device will deteriorate. Be careful not to leave the unit in the following places:

- * Inside a car with the windows closed and in direct sunshine.
- * Near heating appliances.
- * In direct sunshine in summer.

■ Do not subject to shocks

Do not apply shocks to the end of lens and do not attach a heavy conversion lens as this could cause a malfunction. It is recommended that you use a conversion lens weighing less than 100 g.

- Do not hold the unit by the electronic viewfinder or microphone when carrying as this could cause a malfunction.

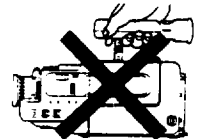

- When the light such as candlelight enters the picture being shot in a dark place, a vertical band of lines may appear.

Important for United Kingdom

The wires in the AC Adaptor mains lead are coloured in accordance with the following code:

BLUE:Neutral BROWN:Live

As the colours of the wires in the mains lead of the AC Adaptor may not correspond with the coloured markings identifying the terminals in your plug proceed as follows. The wire which is coloured BROWN must be connected to the terminal marked with the letter L or coloured BROWN or RED. The wire which is coloured BLUE must be connected to the terminal marked with the letter N or coloured BLUE or BLACK.

Accessories

- ① PV-A510E AC adaptor charger
- ② PV-RF500E RF converter unit (Except in France)
- ③ NP-55 Battery pack
- ④ P5-15 8mm video tape
- ⑤ PV-ZS500 Shoulder strap
- ⑥ Lithium battery (CR2025)
- ⑦ PV-YK500 AV output cable (France ONLY)
- ⑧ AV connection cable (France ONLY)
- ⑨ PV-Z500 Carrying case

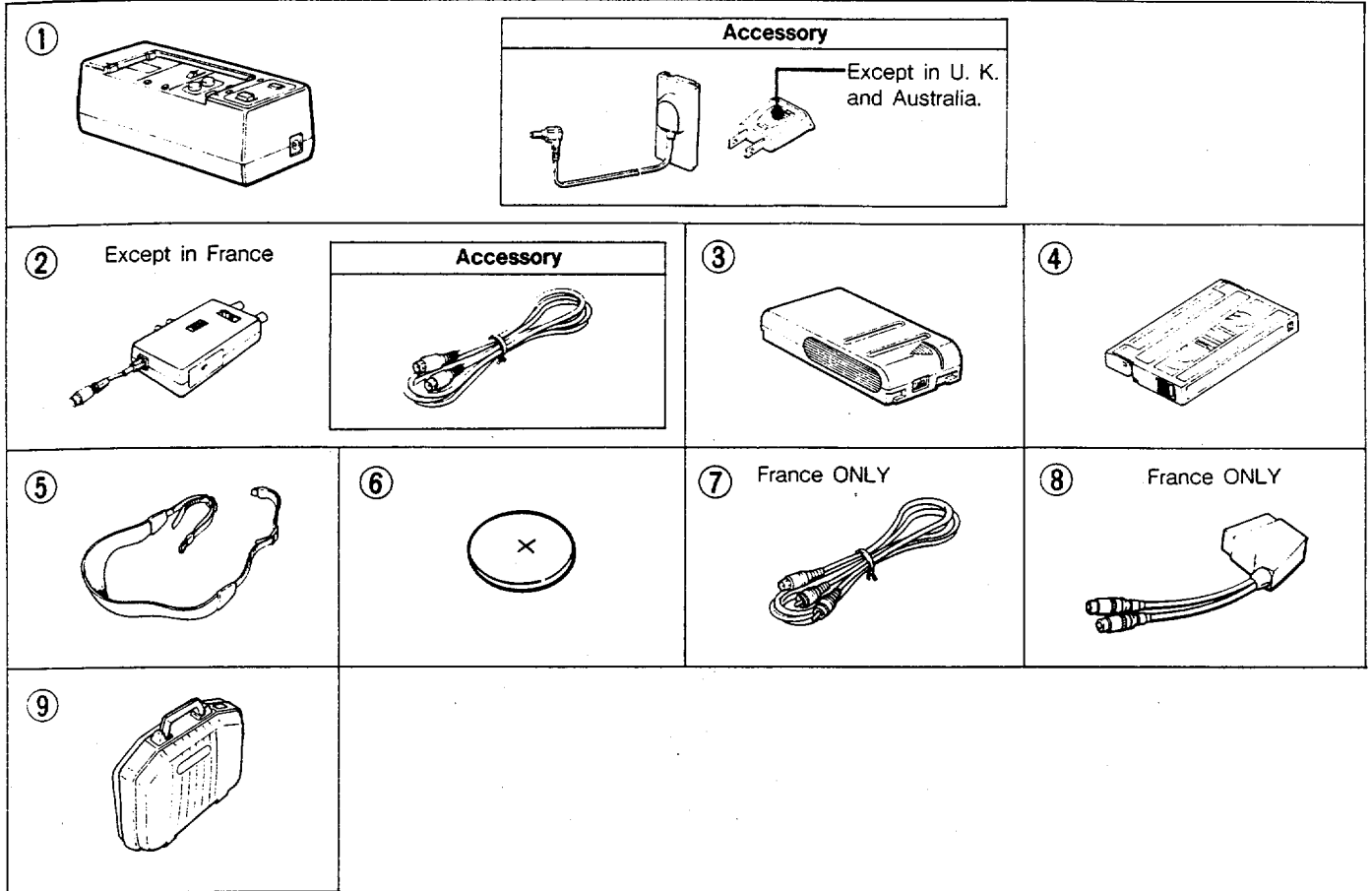

OPTIONAL ACCESSORIES

Battery pack NP-55	• A fully charged battery pack allows using continuously for about 45 minutes.
Battery pack NP-77	• A fully charged battery pack allows using continuously for about 90 minutes.
Rain jacket PV-RJ500	• Convenient for sudden rain.
Wide conversion lens PC-W50	• Serves excellently when wider-angle shots (0.7x) are needed.
Tele conversion lens PC-T50	• Exhibits its real capability when further close-ups (1.4x) are needed.
Filter set PC-F49	• Multi-coat lens protector and ND-8 filter are combined into a set.
Soft case PV-Z510	• Convenient for handy transport.
Camera holder PC-Y800	• Prevents unintentional movement of the hands in making a film record.
AV output cable PV-YK500	• Used in place of the RF converter unit to see video playback with an AV output. Provides easy connections and transport.
Car battery adaptor PV-YC510E	• Connecting the adaptor to the automobile cigar lighter socket charges the battery pack or feeds power to the 8mm video camera/recorder proper.

Part Names

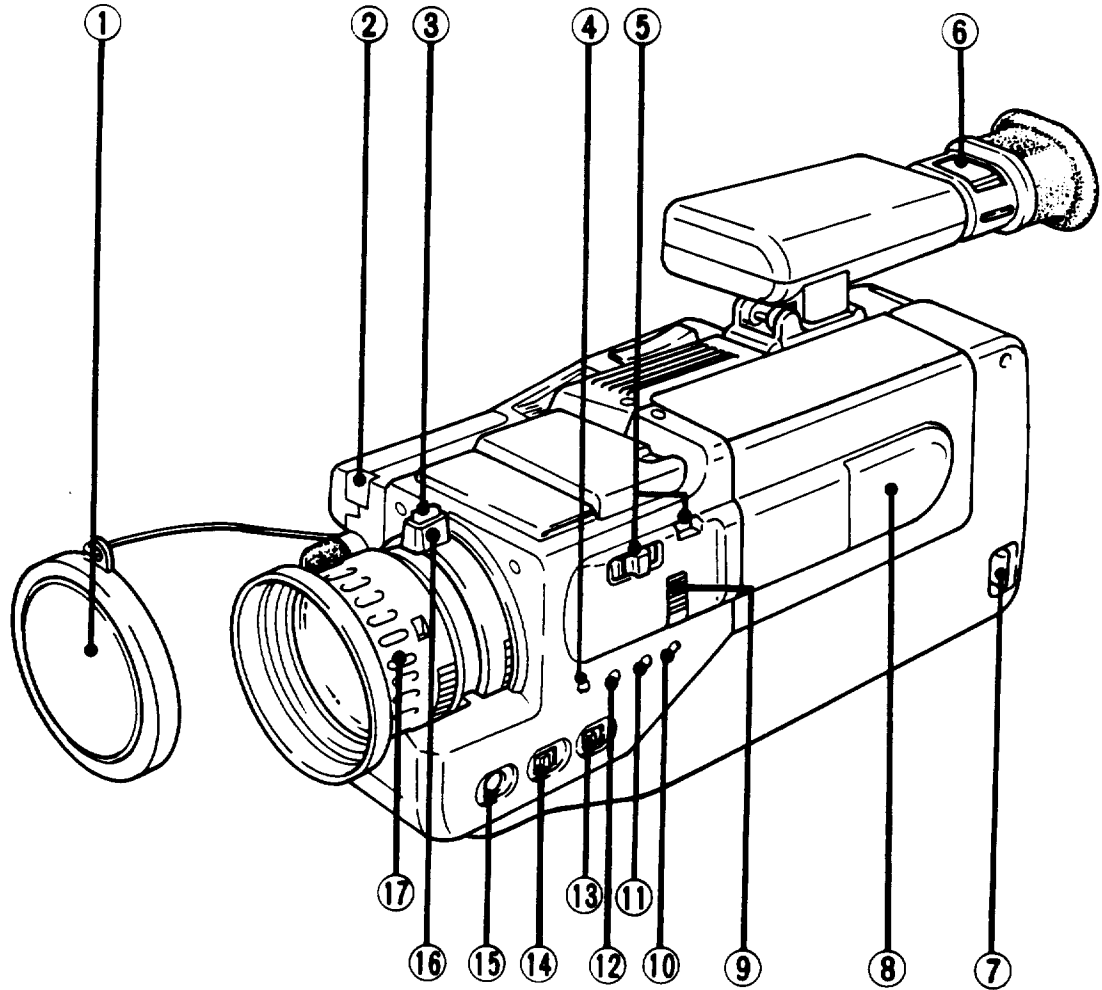

No.	Name
①	Lens cap
②	WHITE SENSOR
③	MACRO SET button
④	RESET button
⑤	OPE. switch and lamp
⑥	Eyesight compensation lever
⑦	BATTERY EJECT button
⑧	Cassette door
⑨	EJECT button

No.	Name
⑩	DATE ADJ button
⑪	DATE ON/OFF button
⑫	MEMORY button
⑬	IRIS switch
⑭	FOCUS switch
⑮	HIGH SPEED SHUTTER button
⑯	Zoom lever
⑰	Focus ring

Note:

- Covering the white sensor ② during recording will result in reduced recording performance.

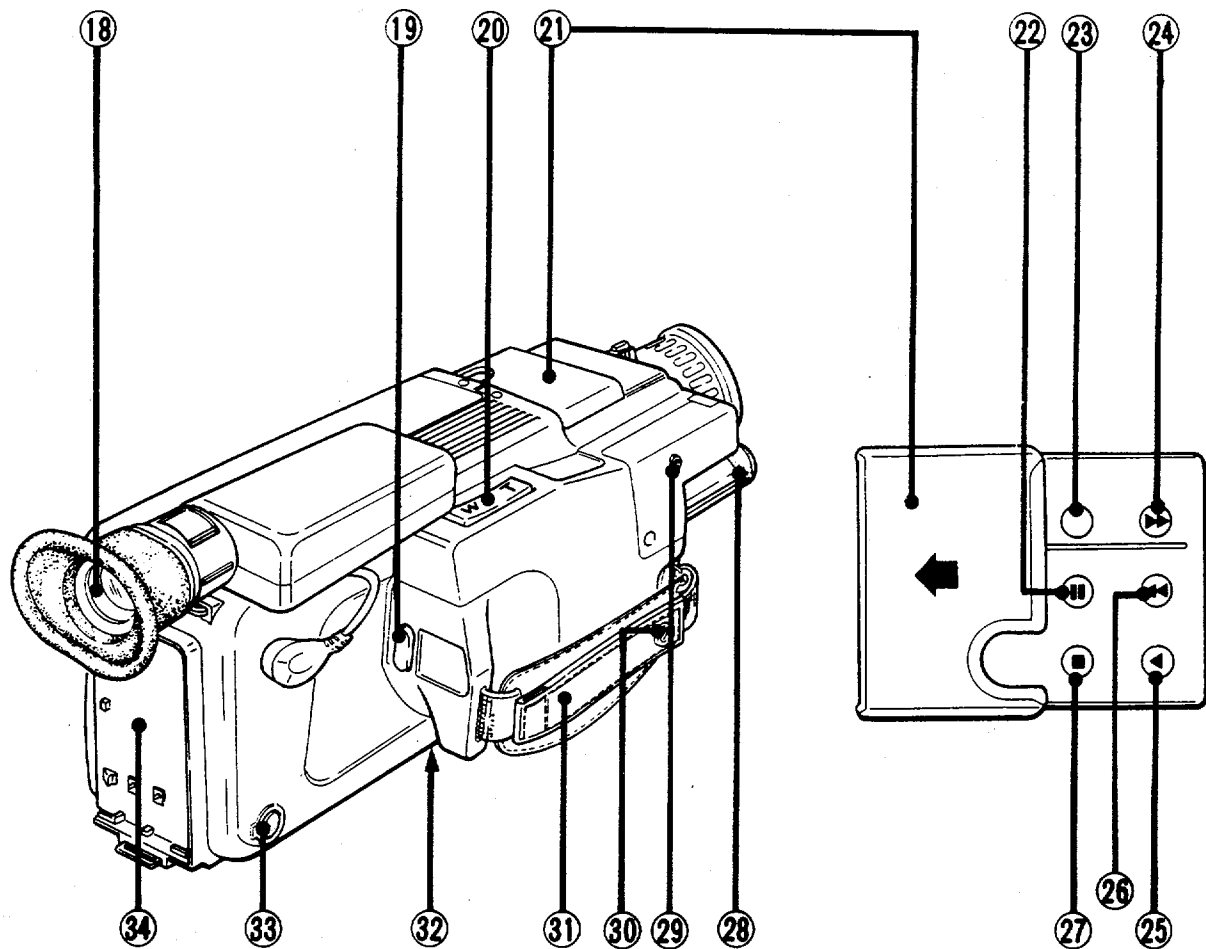

No.	Name
⑱	Viewfinder
⑲	REC START/STOP button
⑳	Power zoom button
㉑	Operation cover
㉒	PAUSE/STILL button
㉓	REC button
㉔	REW button
㉕	PLAY button
㉖	FF button

No.	Name
㉗	STOP button
㉘	Microphone
㉙	EXT.MIC jack
㉚	Lens cap holder
㉛	Grip belt
㉜	Tripod screw mount
㉝	8Pin OUTPUT terminal
㉞	Battery holder

Note:

- The lens cap ① can be conveniently attached to the lens cap holder ⑳ when recording.

Preparations

VIEWFINDER

Attaching the viewfinder

1. Insert the viewfinder until a "click" is heard by press the lever as shown in the figure.

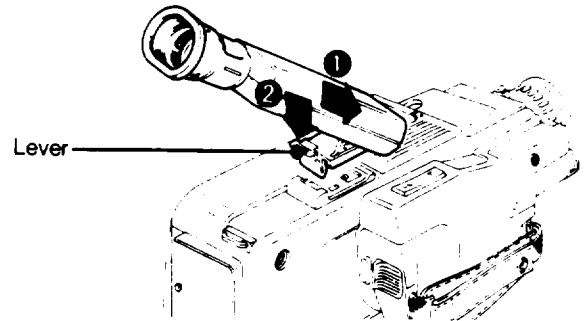

2. Insert the plug into the viewfinder terminal

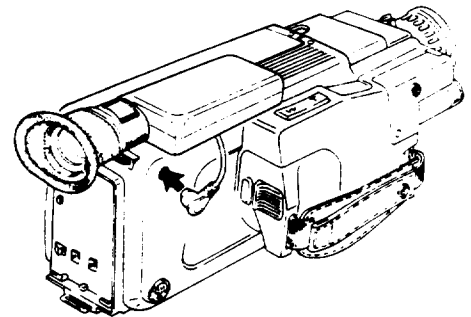

Removing the viewfinder

1. Pull out the plug.

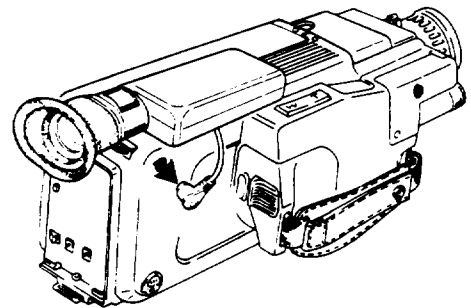

2. Lift the viewfinder press the lever, and remove the assembly.

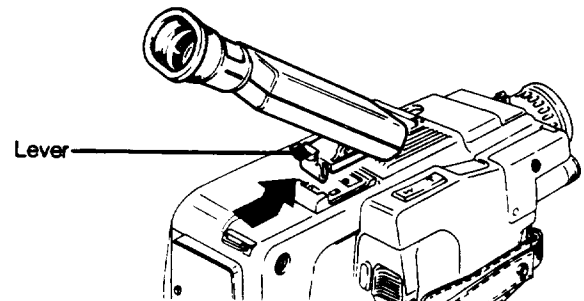

MOVABLE VIEWFINDER

Before operating

- Move the viewfinder backward.

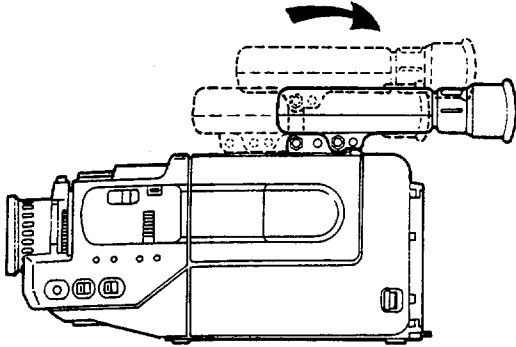

Before storing

- Move the viewfinder forward.

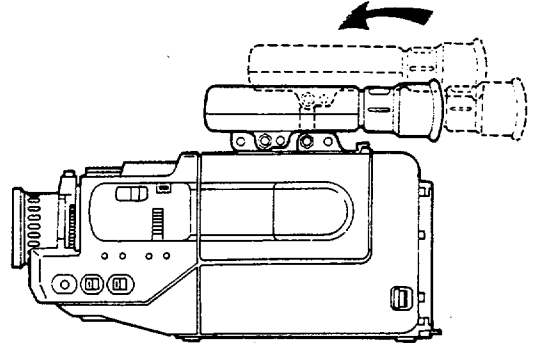

In recording at a low angle

- Since the view finder can move freely up to about 85° in the direction of the arrow, a small child can be easily photographed with the camera at the child's own level.

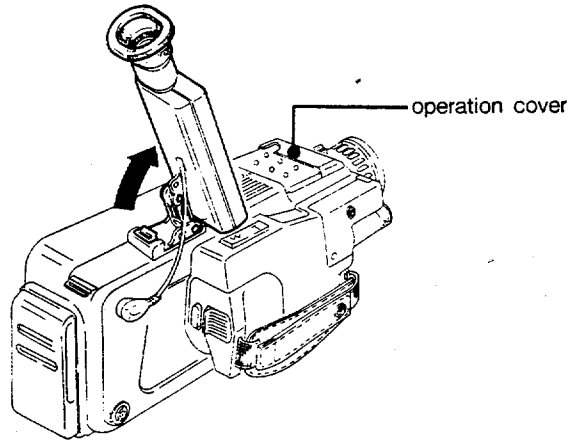

HINT:

In recording at a low angle, it is convenient to open the operation cover and press the PAUSE/STILL button instead of the REC START/STOP button.

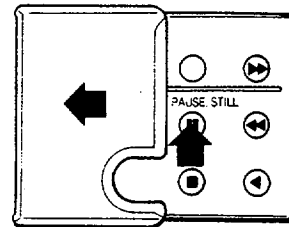

Note:

- Never carry the unit by grasping the viewfinder, to prevent damage to the cabinet.

POWER SOURCE

- The battery pack (NP-55 or NP-77) should be used for outdoor recording

Attachment

1. Align the mark on side and face of battery pack.
2. Slide the battery pack while pressing.

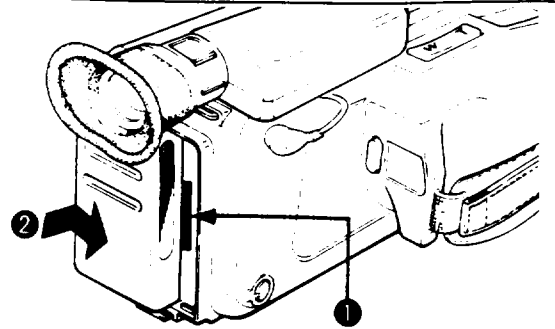

Removal

1. Pressing the BATTERY EJECT button.
2. Slide the battery pack off.

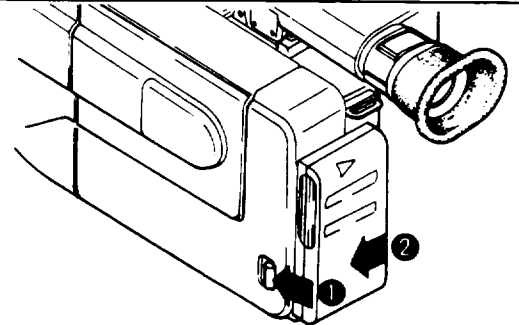

- For indoor use, the AC adaptor charger (PV-A510E) can be used as the power source.

This unit can be used overseas as it can be used in countries using voltage between AC 100V and 240V. Attach the power connection cord supplied with the AC adaptor charger in the same manner as the battery pack.

When using overseas, the shape of the power plug varies according to region. Use the plug adaptor supplied with the AC adaptor charger. (But it is not supplied in U. K. and Australia.)

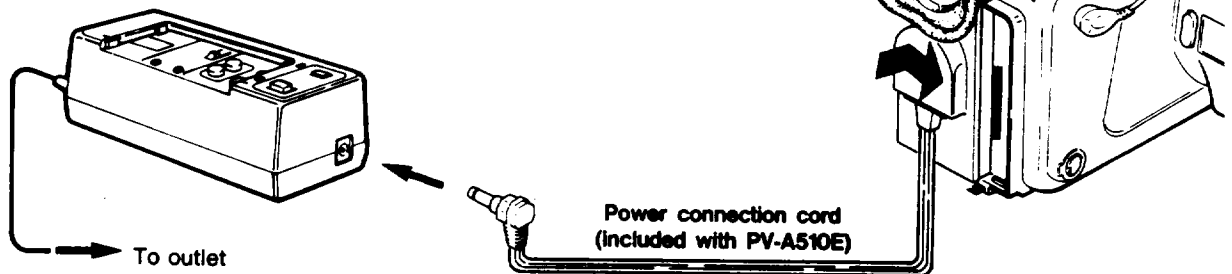

Notes:

- The battery pack supplied with this unit has not been charged. Charge it before initial use. (See page 8)
- Use the PV-A510E (with Power connection cord) AC adaptor charger with the PV-C840E 8 mm VIDEO CAMERA/RECORDER only.

CHARGING

The AC adaptor charger PV-A510E can be used for charging the battery pack.

1. Attaching the battery pack.
Align the  marks, then while pressing down, slide the battery pack in the arrow direction.

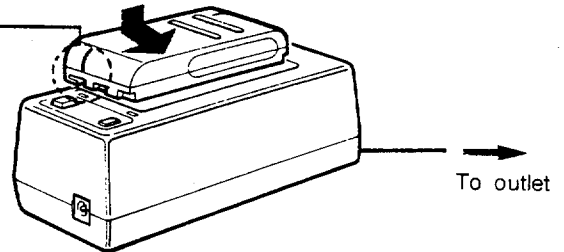

2. Depress the POWER button.
The POWER lamp (green) will illuminate

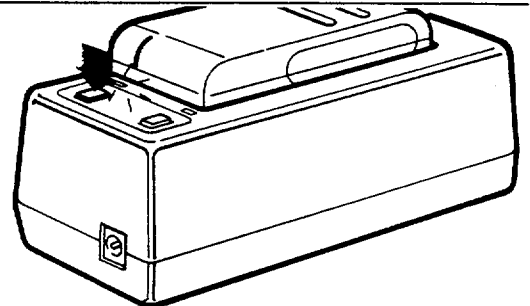

3. Press the CHARGE button.
The CHARGE lamp (red) will illuminate and charging will begin.
When charging is completed, the CHARGE lamp will change to yellow. The battery pack (NP-55) can be charged in about one hour. (NP-77 is two hour)
Depress the POWER button again to turn off the unit.

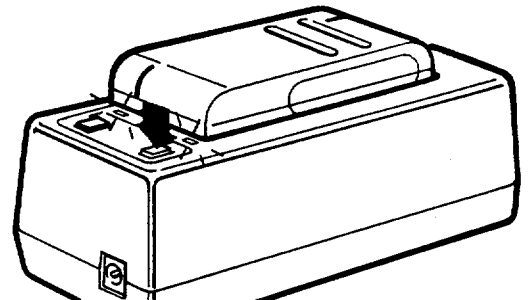

• The AC adaptor charger cannot be used as a power supply while charging.

After charging

Set the switch so that the red circle is not visible.

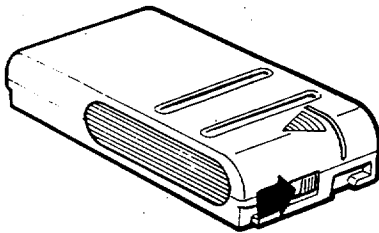

Battery pack is exhausted

Set the switch so that the red circle is visible.

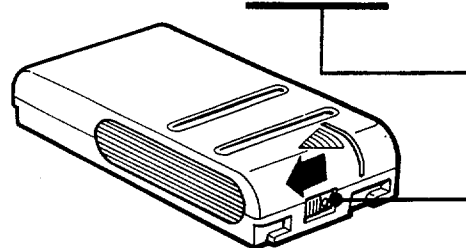

Notes:

- Fully charged, the battery pack NP-55 will provide power for about 45 minutes, and the battery pack NP-77 for about 90 minutes. It will provide much less recording time if the ambient temperature is low. Always prepare as many packs as required for two or three times the planned recording length.
- When the battery pack is exhausted, the BATTERY mark flashes in the viewfinder. Replace the battery pack as soon as possible if this mark appears.
- Do not use PV-A510E AC adaptor charger for other purposes than charging NP-55 or NP-77 battery packs.
- Do not continue charging a fully charged battery pack, because doing so will adversely affect its performance.
- Although charging within a temperature range of 5 °C ~ 35 °C, for best results, a temperature range of 10 °C ~ 30 °C is suggested.

ABOUT 8mm VIDEO TAPE

Only 8mm video tape can be used in this unit.

Cassette insertion/ejection

1. Turn the OPE switch on and press the EJECT button down.
The OPE lamp will illuminate.
It takes about 7 seconds for the cassette door to open.

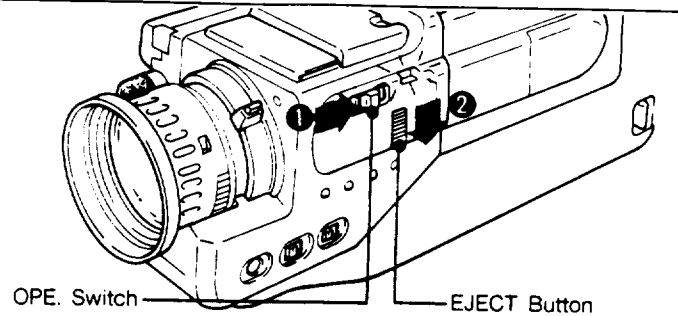

2. Insert the cassette firmly and push the cassette door closed.
The door will automatically close. Do not force it by pressing too hard in the shaded position.

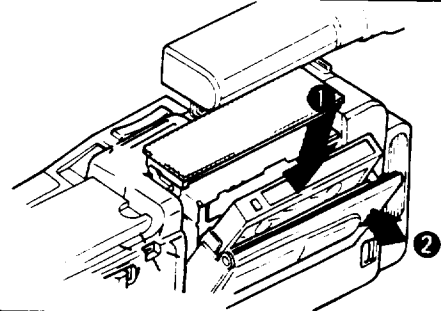

3. To eject the cassette, press the EJECT button down.

Video tape size

Size			
P5-15	P5-30	P5-60	P5-90
15 min	30 min	60 min	90 min

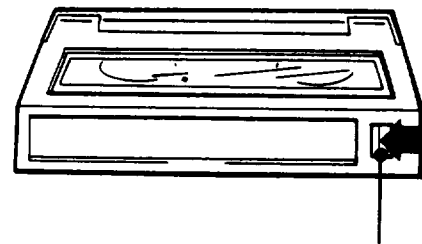

ERASURE-PREVENTION Switch

To prevent the accidental erasure of recorded material, set the switch on the spine of the cassette to the position. This prevents recording on the cassette. To record on it later, return the switch to the original position.

Notes:

- Never carry this unit by grasping the cassette door.
- Do not cover the holes on the bottom of the cassette. These holes are used to determine the type and length of tape and whether or not recording is possible.
- Store the video tape cassettes in their case and standing upright (vertical); this will prevent the entrance of dust and uneven tape winding.
- To record from the beginning of the tape, run the camcorder for about 15 seconds at the beginning of a cassette before recording. This will help you to avoid missing starting point when tape is playback on an 8 mm video cassette recorder.

LITHIUM BATTERY

The date function of this unit is powered by a lithium battery. This prevents the calendar interruption loss even when the power is turned off. The lithium battery has a life of approximately 1 year when used normally. It is recommended that the battery be replaced regularly.

Lithium Battery Insertion

The same procedure is used for replacement. (Lithium Battery: CR2025 [3 V])

- 1 Open the battery cover with the power supply turned on

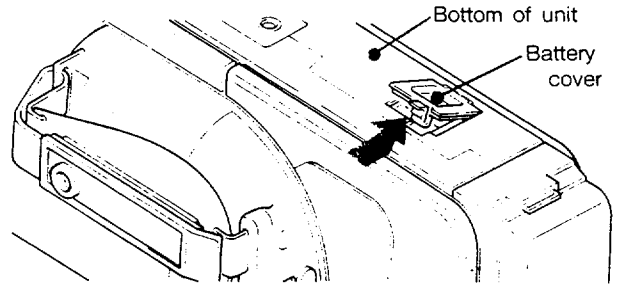

- 2 Insert the lithium battery. (Push in for insertion.)
Be sure to wipe with a dry cloth to prevent faulty contact. Insert properly with the + side up.

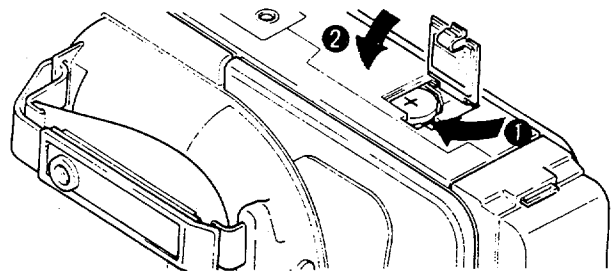

- 3 Close the battery cover.

Precaution for Replacement

Replace the lithium battery only when the power of the unit is on. Replacing the battery with the power off will cause the loss of date data. (It is necessary to set the date again if this occurs. See page 20, 21, and 22)

Notes:

- Keep the lithium battery out of the reach of children.
- Do not grasp the battery with metallic tweezers, etc., as this is liable to cause a short.
- Do not disassemble, subject to heat, or place the battery in water due to the danger of explosion. When discarding, treat the battery as non-burnable garbage.

Warning:

Lithium battery. Danger of explosion if handled carelessly. Replace the battery with the same manufacture and type. Return the old battery to the supplier.

Camera Recording

1. Set the FOCUS switch to the AUTO position.

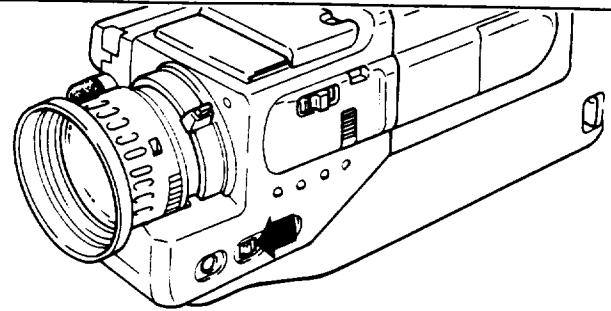

2. Set the IRIS switch to the NORM position.

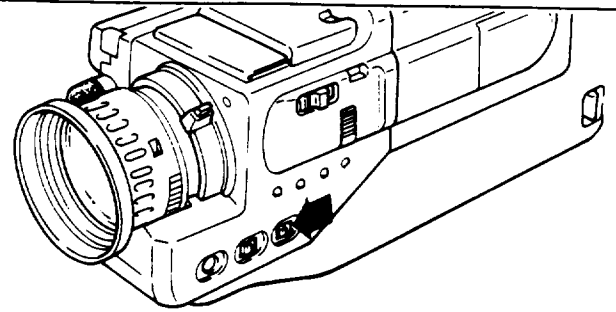

3. Turn the OPE. switch on, push the EJECT button down.
Use battery pack or AC adaptor charger as the power source.
(See page 7)

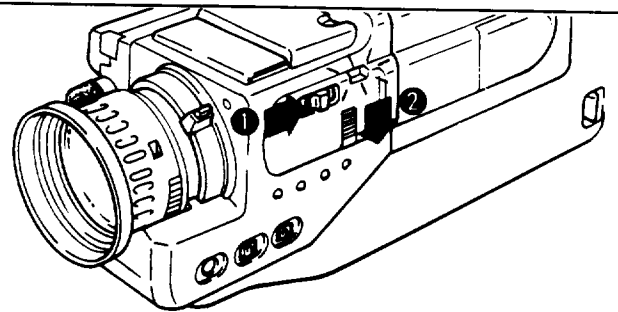

4. Insert a cassette
The unit automatically starts in the REC/PAUSE mode when a cassette is inserted and door is closed.

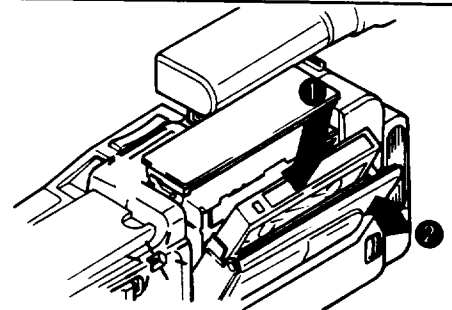

5. Press the REC START/STOP button.
The recording will begin.
To enter into recording pause mode, press the same button.
To return to recording mode, press the same button again.
When you have finished recording.
Eject the cassette and then turn off the power.

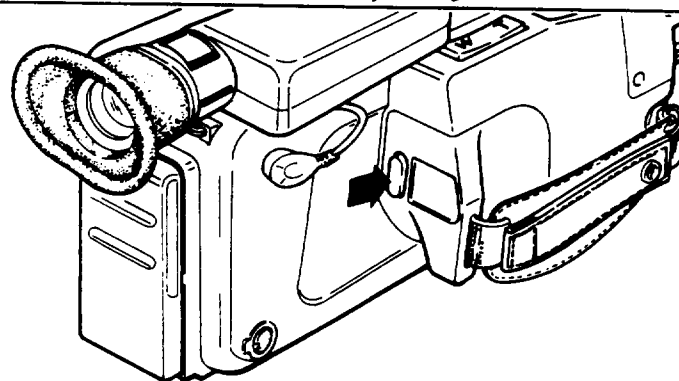

INSIDE VIEWFINDER

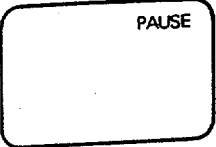
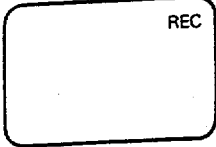
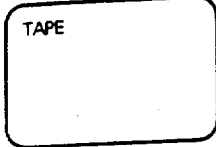
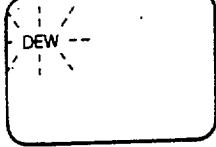
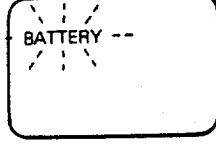
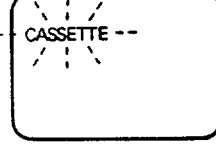
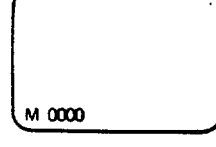
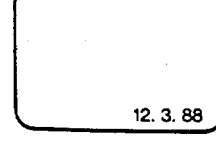
	<p>This indicates record pause.</p>
	<p>This is visible during record mode.</p>
	<p>This indicates about five minutes of tape left.</p>
	<p>When dew (condensation) occurs. . . This warning will flash.</p>
	<p>When the battery is weak, this indication will flash.</p>
	<p>No cassette inserted. Tape is at end. Cassette is set for erase prevention. The unit can not record normally. The tape is moist.</p> <p>— in recording mode ... This mark appear in flashes.</p>
	<p>Tape counter and memory indication.(See page 23)</p>
	<p>Date indication.(See page 20)</p>

Notes:

- Vertical striped bands may appear if recording is attempted by candle light or in other conditions where the light is dim. This is not an indication of a malfunction.
- When using BATTERY power.
When recording pause mode continues for about 5 minutes or over, the power supply will be turned OFF automatically. With AC power, the unit enters into stop mode. When stop mode continues for about 5 minutes or over, the power supply will be turned OFF automatically.
- When shooting under illumination which uses a discharge tube such as fluorescent lights or mercury-vapor lamp, the images will flicker.

Eyesight compensation

Move the compensation adjustment lever until the image is clearly seen.

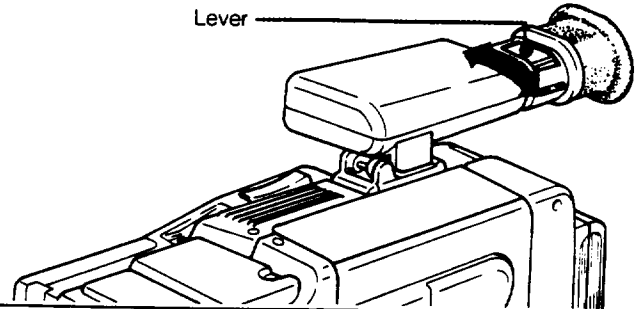

Grip belt adjustment

Tightening the grip belt will help steady your shooting.

Use the lens cap holder to hold the lens cap during shooting.

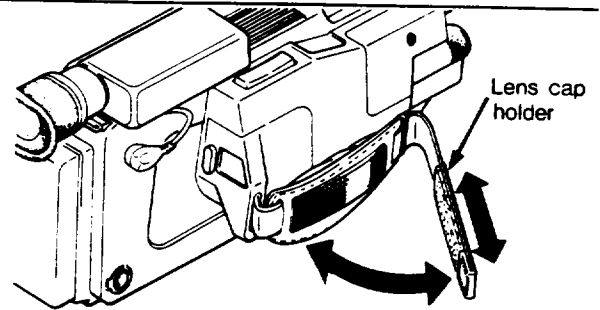

MICROPHONE

The built-in microphone is the monaural, omnidirectional type. An external microphone allows shooting subjects at a greater distance.

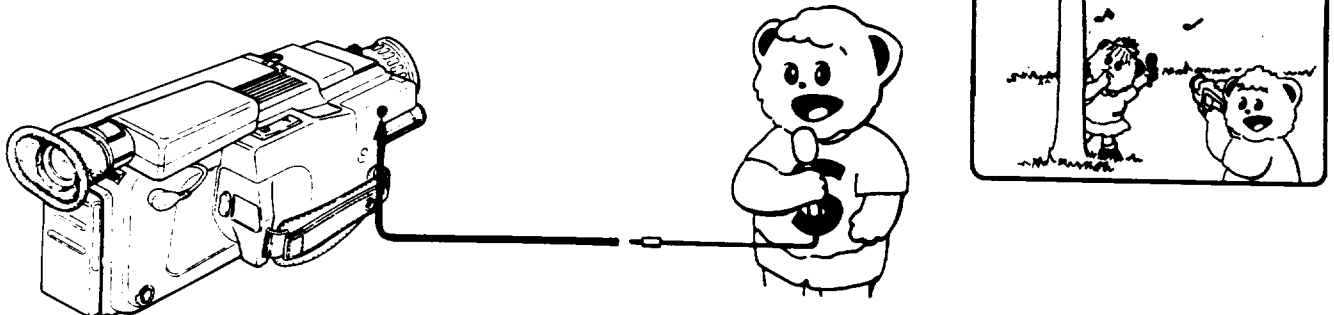

Note:

- The built-in microphone will not function while an external microphone is connected.

Playback

The material recorded on the tape can be viewed on a TV. For connection instructions: see pages 24 and 25. Playback can also be viewed in the viewfinder of this unit.

1. Turn the OPE. switch on and press the EJECT button down.

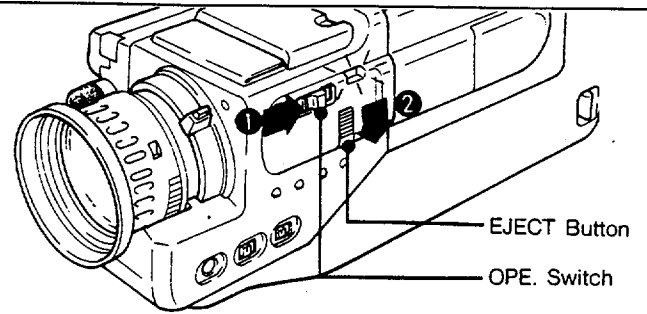

2. Insert the cassette.

Skip step 3. (press the STOP button), if the cassette has already been protected against accidental erasure.

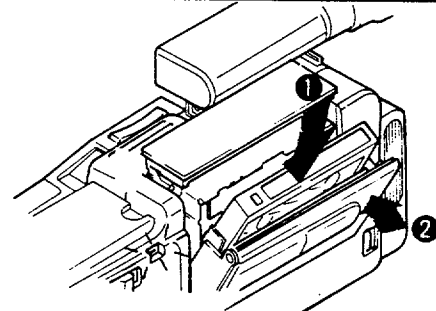

3. Open the operation cover and press the STOP button.

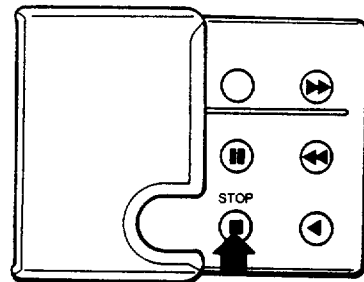
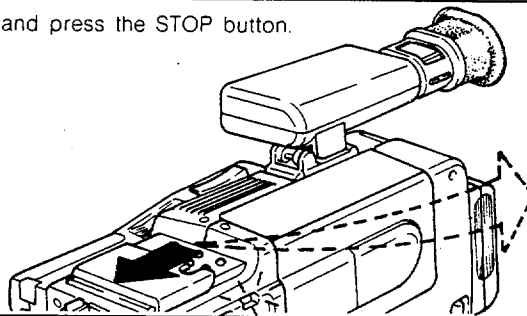

4. Press the PLAY button.
The playback will begin.
To stop the tape, press the STOP button.

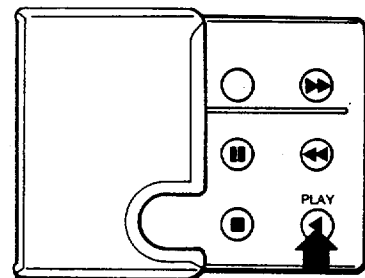

Note:

- To return to recording from the stop mode, press the REC button. This will change the unit to the recording pause mode.

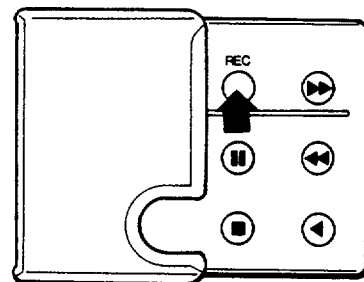

SPECIAL PLAYBACK MODES

Picture search

Press the FF button or the REW button during playback. The tape will move fast forward or backward while the button is held.

- **Note:** horizontal lines will appear in the picture during picture search.

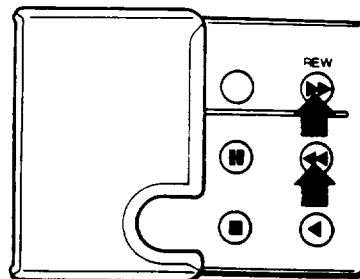
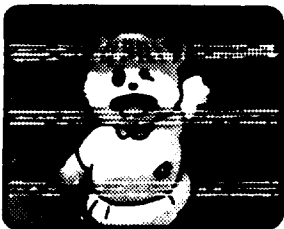

Still playback

Press the PAUSE/STILL button during playback: a still picture can be seen. To return to normal playback, press the same button again.

- **Note:** noise will appear in the picture during still playback.
- **Note:** there will be an automatic change to the stop mode if still playback is continued for five minutes or longer.

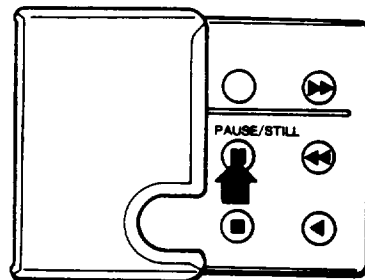

Recording Review

The final portion of a recording just made can be played back on the viewfinder to check its contents. This is called recording review.

Press the PLAY button during the recording pause mode.
When confirmation is completed, it enters again into recording pause mode.
"RECREVIEW" will be indicated on the operation cover.

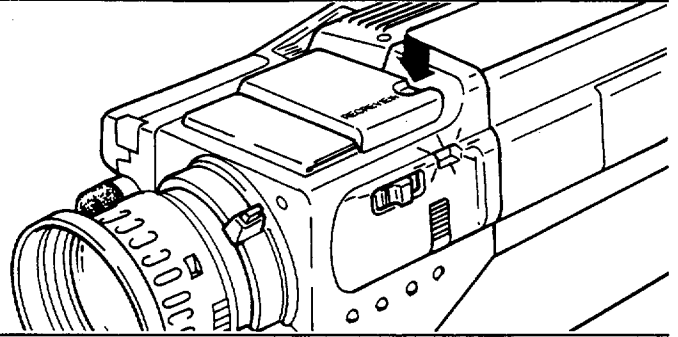

Zoom

There are two methods for zooming, i.e., one is powered and the other manual. In either method, zooming effect is enhanced even more by shooting a fixed object for several seconds before and after the zooming.

Power zooming

This permits zooming in or out at a constant speed.

Press "W"for wide angle

Press "T"for telephoto

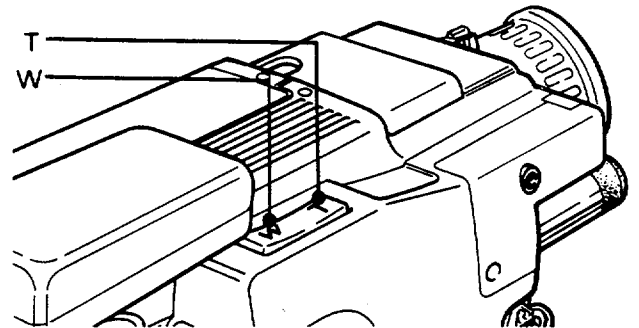

Manual zooming

Manual zooming lets you zoom at the speed you want.

Turn to for telephoto

Turn to for wide angle

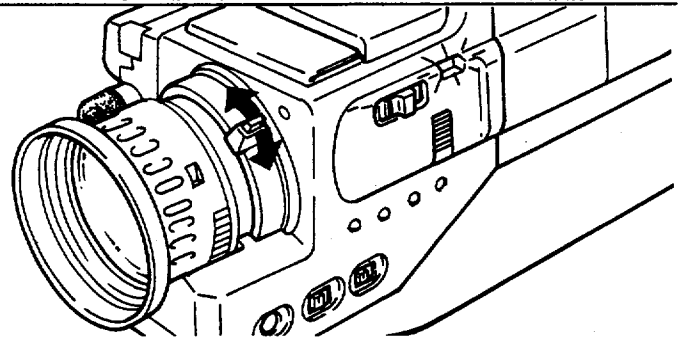

Macro (close-up)

Under ordinary conditions, an object cannot be focused if it is within about 1.1 m from the camera however by using the special macro device, focusing up to about 5 mm from the lens is possible, and an object the size of a cigarette pack will fill the entire lens.

1. Set the FOCUS switch to MAN.

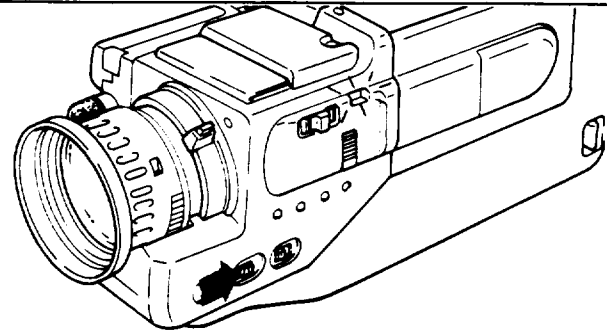

2. Press and hold the MACRO SET button.

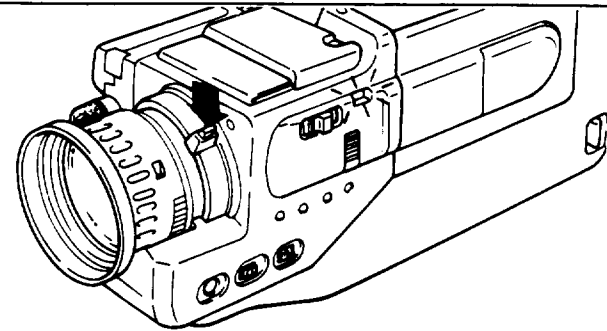

3. Move the manual zoom lever to the MACRO range.
A : MACRO range

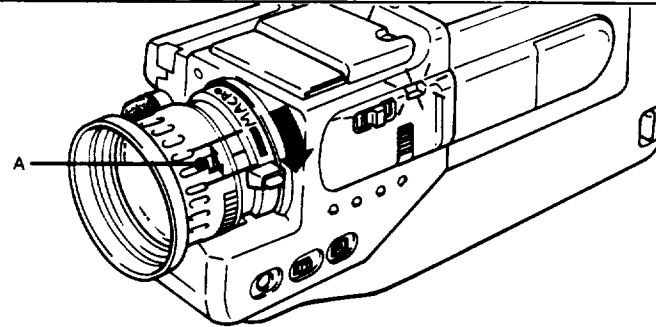

4. Approach the object and use the manual zoom lever to focus.
Adjust within the MACRO range.
B : Within about 1.1m

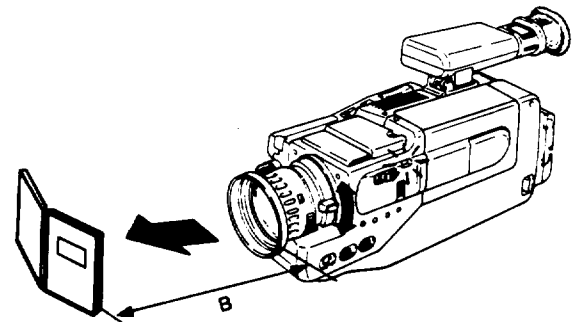

Notes:

- The zoom feature cannot be used for macro recording. To reduce the size of the object in the viewfinder, the camera and the object must be moved farther apart.
- As shaking is a problem with macro shooting, it is recommended that a tripod be used or the camera be fixed in place using a stand.

Lens Aperture

Iris of the lens is adjusted automatically in accordance with the brightness of the environment. Turn the IRIS switch on when contour of subject become vague when shooting with a strong backlight.

Set the IRIS switch to the BACK LIGHT.

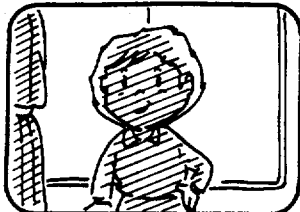

"BACK LIGHT"

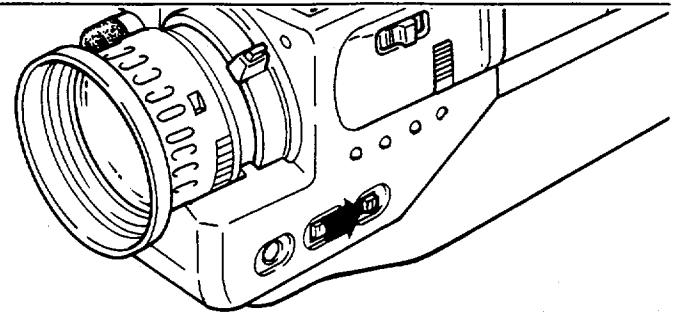

Auto Focusing

The FOCUS switch should usually be set to the "AUTO" position. For automatic focus, the vicinity in the center of the viewfinder is in focus.

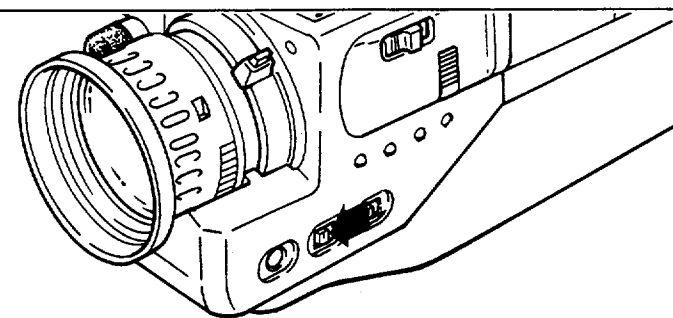

The auto-focus feature does not function normally against the following objects. In these cases, adjust the focus manually. (See next page.)

<p>When shooting near and far objects together:</p>	<p>When shooting an object through a dirty glass:</p>	<p>When shooting a dark object:</p>
<p>When shooting objects which have no contrast such as white wall, sky, etc.:</p>	<p>When shooting an object which has lateral stripes:</p>	<p>When shooting an extremely bright object:</p>

Notes:

- While the auto focusing is in progress, do not try to forcibly turn or stop the focus ring.
- If a special filter (such as for vari cross, mirages, etc.) is used, the automatic focus feature may not function normally.
- Use manual focusing for shooting objects moving fast, or with such camera operations as rapid panning, or tilting, etc. The auto-focus would not be stable in these situations.
- When there are other objects passing in front of the subject to be shot, the camera will attempt to focus on these other objects. It is recommended that manual focusing be used in this situation.

Manual focusing

1. Set the FOCUS switch to the "MAN" position.

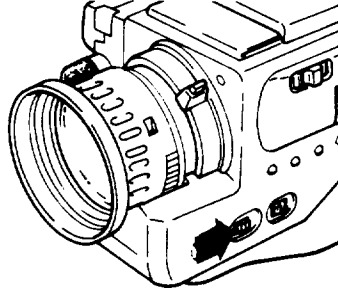

2. Close-up the subject by pressing the POWER ZOOM button.

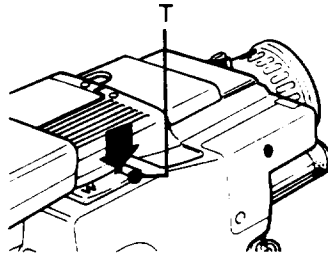
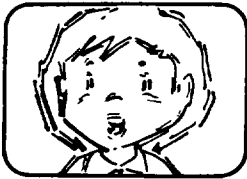

3. Turn the focus ring until the subject is clearly focused.

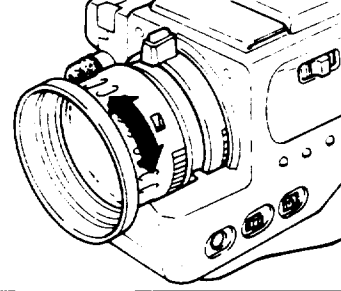
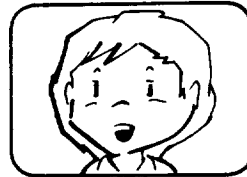

4. Use the zoom to get the desired setting.

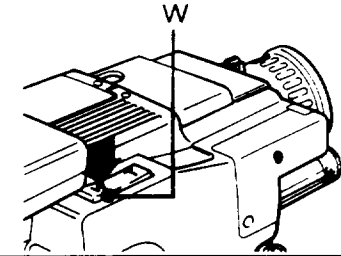
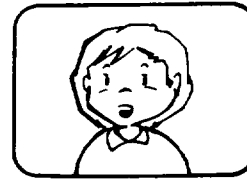

High Speed Shutter

When viewing a recording made with high speed shutter, even very fast-moving objects are not blurred when reproduced using still picture playback. However, there may be picture noise caused by the still function of this unit.

High speed shutter function is operated while the button is pressed.

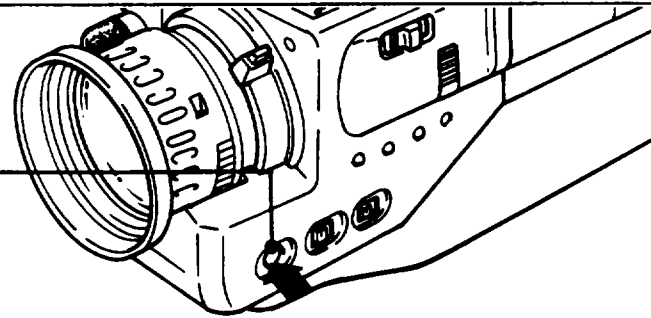

Notes:

- If the high speed shutter is used in low light (e.g. indoors), the picture will be darker than usual. Use the high speed shutter function in bright areas (e.g. on snow, sand, or outdoors on a clear day).
- During normal playback, pictures shot with the high speed shutter will not appear smooth.
- A change in the picture brightness will occur at points where the High Speed Shutter button is pressed or released.

Date Imprint

The date of the recording can be imprinted. See "Date Setting" on this page.

Press the DATE ON/OFF button.
The date will appear in the viewfinder.

Example

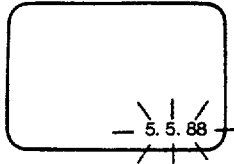

To stop the date imprint.
Press the DATE ON/OFF button again.

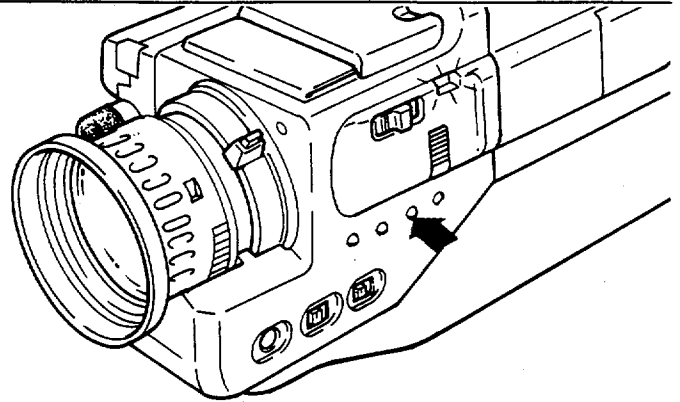

If "88 : 88" flashes by pressing the DATE ON/OFF button, that is because either that date was erased due to exhaustion of the lithium battery or the date has not yet been set (initial state). Set the date by following the "Date Setting" procedure outlined below. (Replace the lithium battery if this is the source of the problem. See page 10)

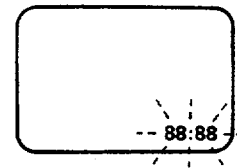

Date setting

Example: PM 2:10 14, 2, 1989

As the date function of this unit operates from the internal clock and the date changes automatically, the time is first set followed by the date.

1. Pressing the DATE ADJ button for about one second.
The time indication will appear. (The diagram below is the initial state)
 - Use a pen etc. to press this button.

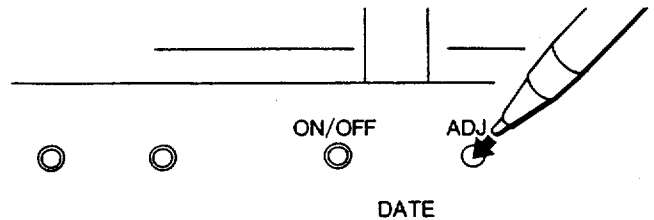
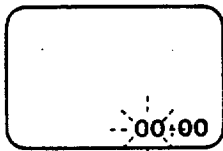

2. Set the hour by pressing the DATE ON/OFF button.

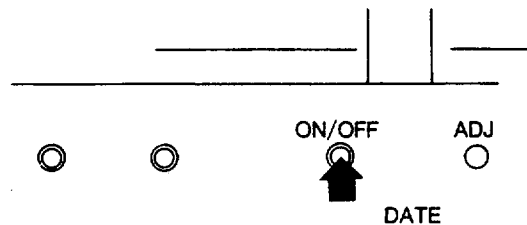
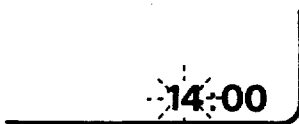

3. Press the DATE ADJ button.
The flash will move right.

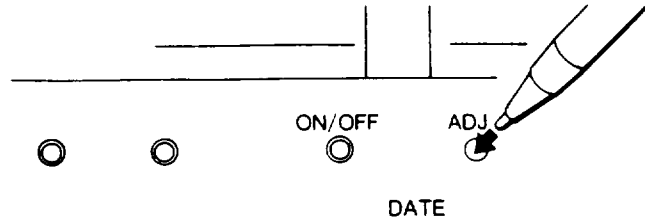
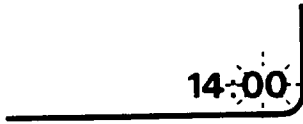

4. Set the minute by press the DATE ON/OFF button.

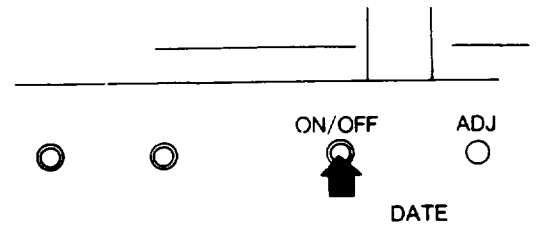

5. Press the DATE ADJ button.
The seconds of the time start from "0 seconds" at this time
The time indication changes to date indication. (The diagram below is the initial state for date indication.)

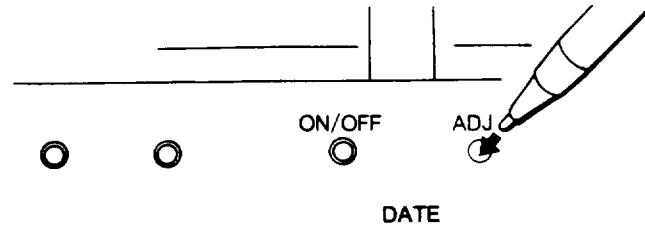
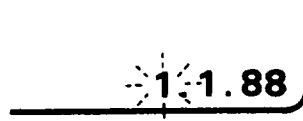

6. Set the day by pressing the DATE ON/OFF button.

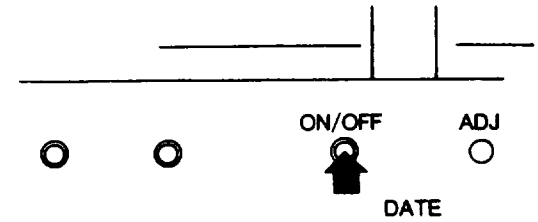
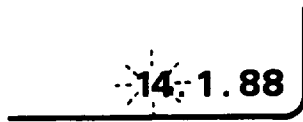

7. Press the DATE ADJ button.
The flash will move right.

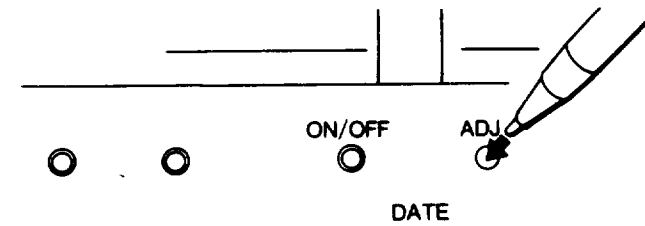
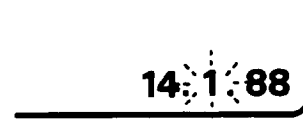

8. Set the month by the DATE ON/OFF button.

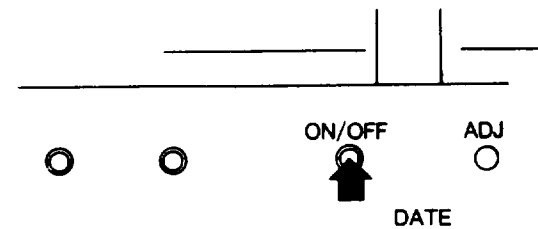
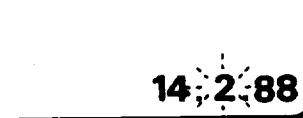

9. Press the DATE ADJ button.
The flash will move right.

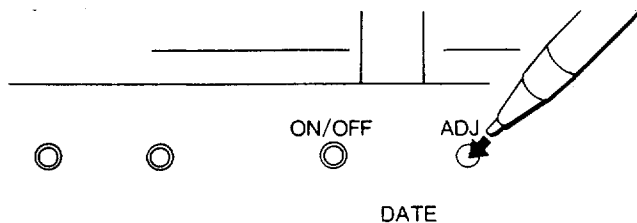
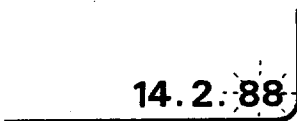

10. Set the A.D. by pressing the DATE ON/OFF button.
The last two digits of the year are indicated, and indication up to 2015 AD is possible. The indication changes in the following manner: 88 → 89.....00.....15 → 87 → 88.

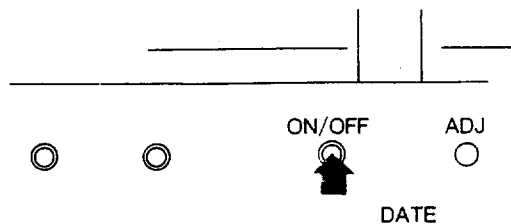
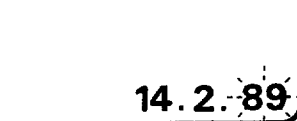

11. Press the DATE ADJ button.
The date indication will automatically disappear.

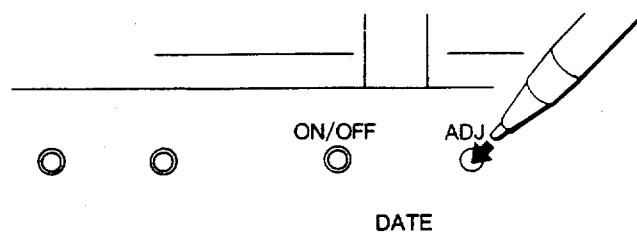

Note:

- The date can not be set during recording or playback. Set the date when the unit is stopped or during fast-forward or reverse.

Tape Counter Operation

The tape counter setting will return to "0000" when the RESET button is pressed. Rewind the tape to its beginning and reset the counter to "0000". The counter can be conveniently used to find the beginning of any of the recordings on the tape. Make a note of the counter reading at the beginning and the end each time a recording is made. The card in the cassette storage case can be used for this purpose.

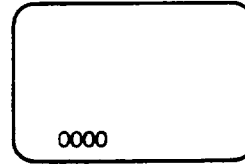
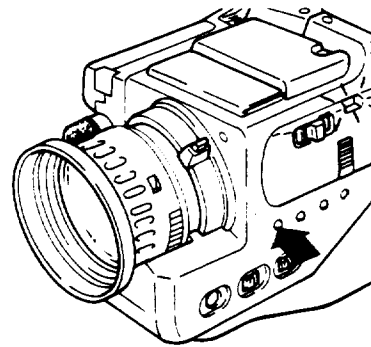

To find the beginning of a recording (MEMORY REWIND)

This counter has memory system. Before starting a recording (or playback) reset the counter to "0000" and press the MEMORY button. The beginning position can be quickly and easily located later. When the tape is rewound after the recording (or playback), it will automatically stop in the vicinity of the "0000" reading of the counter.

1. Press the RESET button.
The tape counter setting will return to "0000".

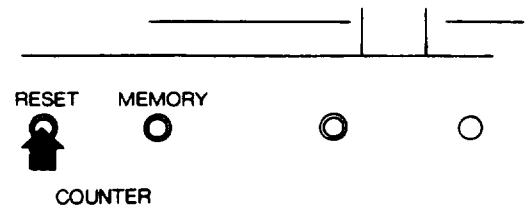
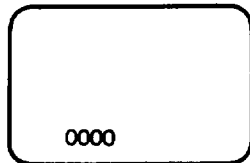

2. Press the MEMORY button.
The letter "M" will appear in the viewfinder. To erase this indication, press the same button again.

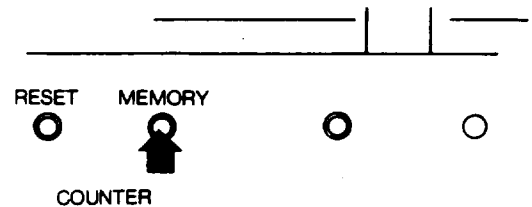
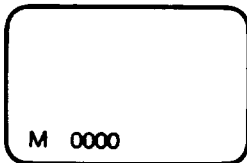

3. When you have finished recording or playback, press the REW button.
The tape will automatically stop in the vicinity of the "0000".

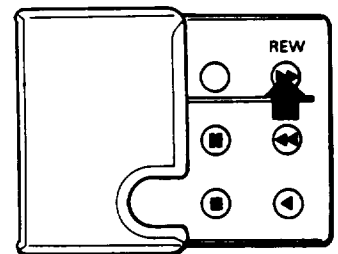
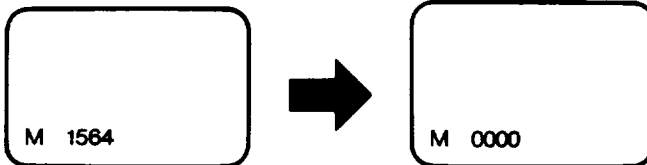

Note:

- The tape counter indication may deviate slightly from the tape position.

Connections

FOR TV'S WITHOUT AUDIO/VIDEO INPUT TERMINAL

For except in Australia and France.
PV-RF500E
RF converter unit

To watch TV playback, adjust the RF CHANNEL screw of the RF adaptor and the TV's channel to the unused channel on which there are no TV broadcasts in your locality.

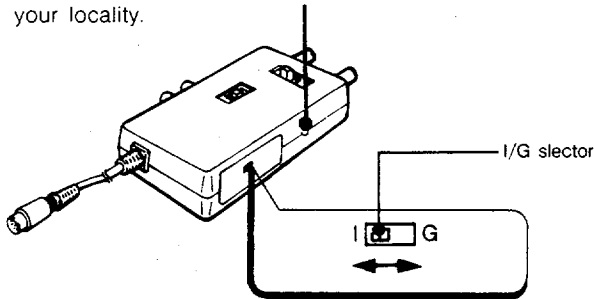

Set the I/G selector to the proper position.

For Australia
PV-RF500E
RF converter unit

To watch TV playback, be sure to set the channel selector of the RF adaptor and TV's channel to the channel (0 or 1) on which there are no TV broadcasts in your locality.

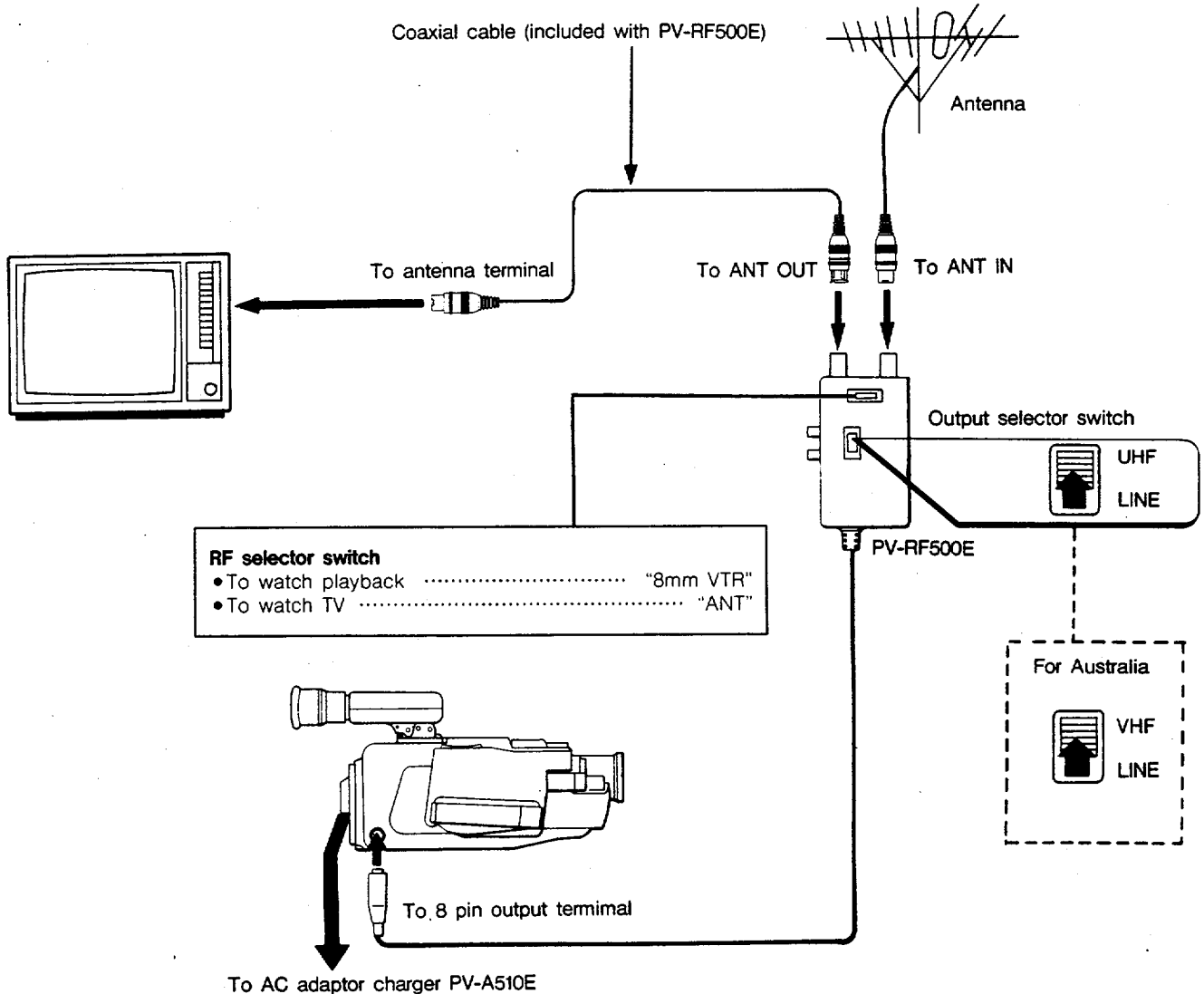
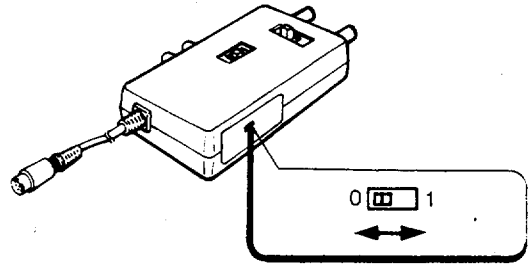

FOR TV'S WITH AUDIO/VIDEO INPUT TERMINAL

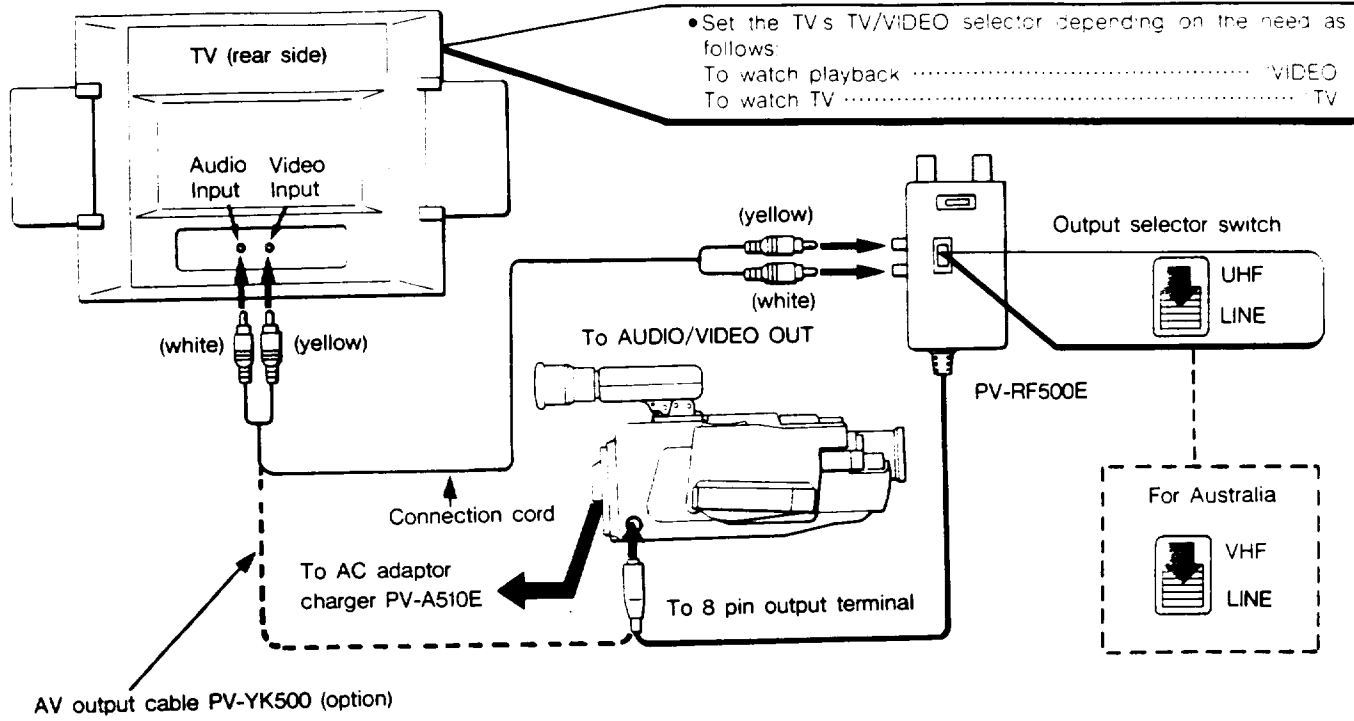

For France ONLY

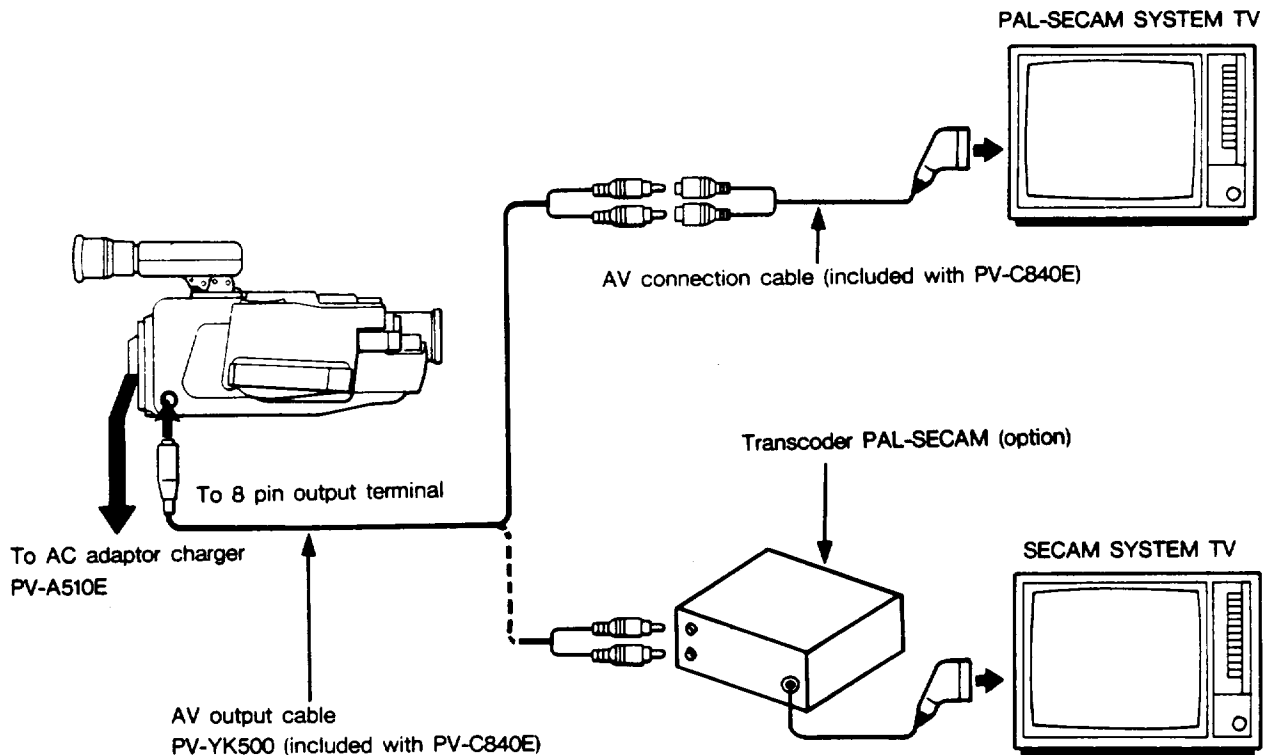

Important Notes

Keep away from high temperatures.

If you leave or use this unit in or near high heat, the exterior of the camcorder may be deformed. Do not leave it in a closed automobile on hot days.

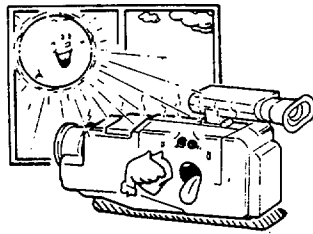

Don't put anything inside.

Trouble and a possible malfunction may result if any foreign substances (flammable articles, metal items such as pins, water, etc.) get inside the unit.

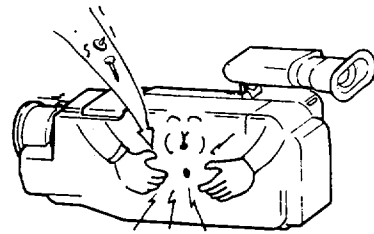

If operation seems abnormal ...

If you notice anything strange (smoke, a strange odor, abnormal noise, etc.), switch OFF the power immediately and refer to the store where it was purchased or Pentax service depot.

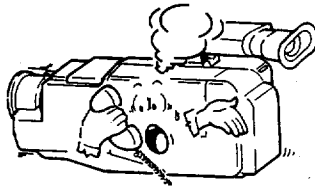

Protect the viewfinder from direct sunlight . . .

• Sunlight entering through the eyepiece is focused and may cause the unit to malfunction.

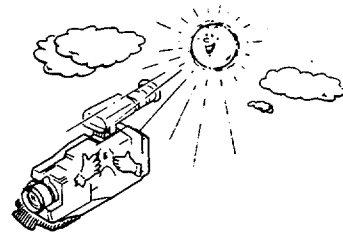

When not using the unit for an extended period of time...

- Remove the tape and the battery pack.
- Operate the unit with the power turned on from time to time.

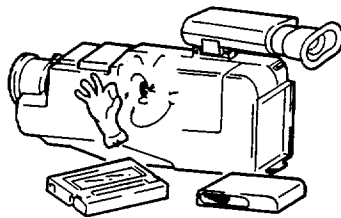

Do not use this unit . . .

- Where there is high humidity (a steamy bathroom for example).
- Where vibrations are violent.
- Where there is excessive dust or dirt.
- Where there is high magnetism.

Examples: near a transmitting antenna
near motors
near fluorescent lights

At the beach ...

Take special care to prevent entry of water and sand.

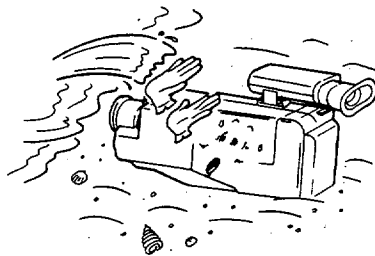

• Do not wrap the unit in a cloth etc.

If wrapped in a cloth, the temperature inside the unit will rise excessively during operation, causing the unit to malfunction.

Video heads

When the video heads have been used for a long time, the playback picture may become fuzzy, and eventually there may be no picture at all.

This is caused by dirty video heads, and is an indication that they should be cleaned.

To clean the heads, use a commercially available cleaning kit, or consult your dealer.

- Note that the video heads can be damaged if a cleaning tape cassette is used incorrectly. Read and follow the pertinent instructions carefully when cleaning the heads.

Video heads wear in the same way as a phono stylus.

If the picture is not clear even though the heads have been cleaned, it is possible that the heads themselves are worn. If so, they must be replaced.

For detailed information and assistance, please consult your dealer.

1000 hours of use is the guideline for an inspections.

This unit requires an extremely high degree of precision to record images from the video camera onto magnetic tape and then to correctly reproduce those images. In particular, the video heads and mechanical parts which transport the tape are especially subject to becoming dirty and worn after long use.

So, in order that you can continue to enjoy the beautiful pictures which this unit can reproduce, it is suggested that the unit be inspected (including cleaning, lubrication and possible replacement of some parts) after approximately every 1000 hours of use.

For detailed information and assistance, please consult your dealer.

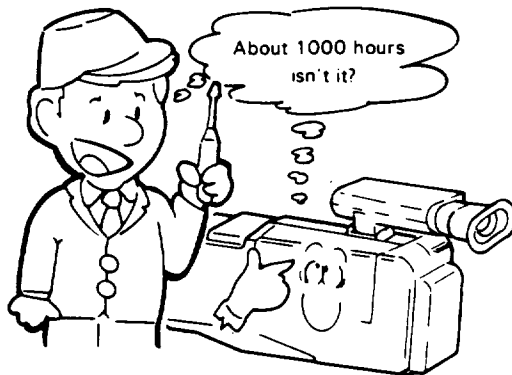

Use in other countries

All you need for recording in a foreign country is a charge battery pack(s) and cassette(s), but if you want to play back the tape in that country, you will have to use a TV with PAL color system and AV input terminals.

Main countries using the PAL system:

England, Italy, Austria, Australia, West Germany, Holland, Kuwait, Singapore, Switzerland, Sweden, Spain, Thailand, People's Republic of China, Denmark, New Zealand, Norway, Belgium, Portugal, Hong Kong

Main countries using the NTSC system:

Canada, Japan, Korea, Mexico, the Philippines, Taiwan, U.S.A.

Main countries using the SECAM system:

Iran, Iraq, USSR, Hungary, France, Bulgaria, Poland, Monaco, Luxemburg, etc.

If a malfunction should unexpectedly occur while in another country, contact the dealer where the unit was purchased.

Before Requesting Service

MOISTURE ("DEW") CONDENSATION

If condensation occurs within this unit, operation of the unit is prevented in order to protect internal mechanisms.

What Moisture ("Dew") is

- The water drops that form on the outside of a cup when it is filled with ice water is called condensation.
- If this condensation forms within the unit and the unit is used in this state, the tape and video heads will be damaged and a malfunction will occur.

Reasons for moisture to occur

- When the unit is brought suddenly into a warm room from the cold outdoors and used.
- When a cold room is heated suddenly by use of a heater.
- In summer, when the unit is brought suddenly into a room having high humidity and/or temperature after being in an air-conditioned room or automobile.

If moisture occurs

- The DEW mark (flashing) appears in the viewfinder.
- If there is a tape in the unit, be sure to remove.
- When the moisture dries up, the DEW mark disappears. The time required for drying varies according to the surrounding temperature.
- Moisture condensation sometimes occurs slowly and the DEW mark may not appear until later despite the occurrence of moisture condensation. Thus in situations where condensation is liable to occur, remove the tape and wait 15 to 25 minutes. The unit can be used if the DEW mark has not appeared.

Preventing Moisture Condensation

When bringing the unit into a heated room from a cold place such as a skiing area, seal the unit in a plastic bag to prevent moisture condensation. Leave the unit in this state for about one hour after bringing into the room.

Moisture on Tape

In the same manner, moisture may form on the tape when it brought from a cold place to a hot place. If a tape with moisture on it is inserted, nothing will happen even when the PLAY button is pressed. Only the EJECT button will work. The CASSETTE mark will appear in the viewfinder at this time. Eject the tape and leave it until the moisture dries.

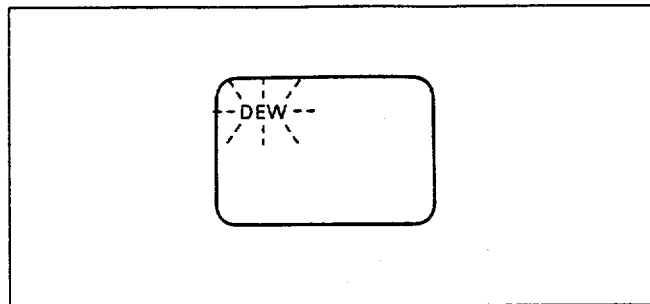
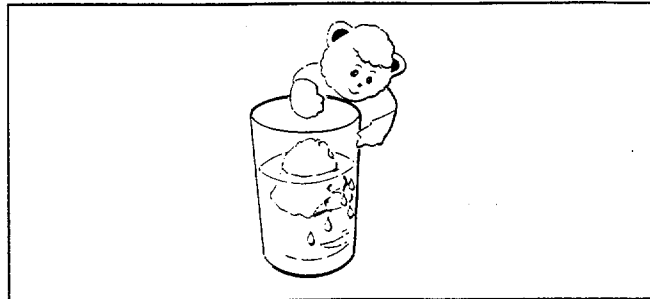

WHEN YOU THINK THERE'S A PROBLEM ...

First check the items below. If operation still seems abnormal, ask store where your unit was purchased for assistance

Symptom	Probable cause	Remedy	Page
No power.	Battery pack is exhausted.	Replace with a charged battery pack	8
	AC adaptor is turned off	Turn on the power	-
	Charging the battery	Stop charging or wait for completed charging	-
Nothing happens even with batteries attached.	Moisture condensation inside the unit.	Wait until the DEW mark in the viewfinder goes OFF.	28
Power is suddenly turned off during use.	Battery pack is exhausted	Replace with a charged battery pack	8
	Stop mode or pause mode is continued for 5 minutes or longer	Turn on the power again	-
Cannot record.	No cassette	Insert a cassette	9
	Cassette is set for erase prevention.	Reset cassette's switch, or insert another cassette.	9
	Tape is at end	Rewind the tape, or insert another cassette.	-
Cannot be focused.	A subject which is difficult to focus on is being shot	Adjust the focus in manually focusing.	18, 19
	Distance to subject is less than 11 m.	Separate or using the macro feature.	17
No picture on the TV	TV channel is not set to the designated video channel	Set the video channel	24
	Mis-connection.	Correct the connection.	24, 25
Playback picture flickers or is blurred.	Video heads are dirty.	Clean them. (If this does not help, heads may need to be replaced.)	-
Cassette holder will not go in.	Moisture occurs.	Wait until the DEW mark in the viewfinder goes OFF.	28

Specifications

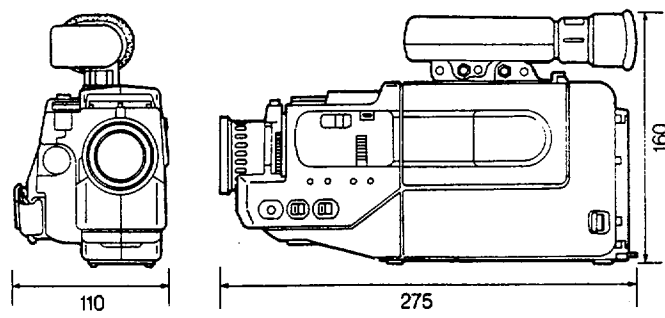
Systems, etc.		Power supplies, etc.	
Video recording system	Rotating 2-head helical-scan FM, color under system	Power supply voltage	Battery holder input 6V/7.5V
Audio recording system	Rotating head FM system	Power consumption	6.5 W during camera recording (including viewfinder)
Video signals	PAL color, CCIR standard system	Operation temperature range	0 °C ~ +40 °C (32°F ~ 104°F)
Cassette type	8 mm video tape cassette	Storage temperature range	-20 °C ~ +60 °C (-4 °F ~ 140 °F)
Tape speed	Approx. 20.051 mm/sec.	External dimensions	110 × 160 × 275mm (W × H × D) (when storing the viewfinder)
Recording/playback time	90 minutes(P5-90 cassette)		
Fast forward/rewind time	Approx. 5 minutes (P5-90 cassette)		
Pickup element	CCD solid-state type	Weight	Approx. 1.1 kg (not including battery pack and cassette)
Viewfinder	Electronic(0.7 inch type, black and white)	Microphone	Electret condenser type (omnidirectional)
Lens	Electro-powered 6X zoom lens f =9~54 mm F1.6 Close-up function(5 mm~1.1 m) Automatic focus Filter diameter 49 mm	8 pin OUTPUT terminal	Video output 1 Vp-p, 75 Ω unbalanced, negative sync Audio output -6 dBs, 2.2kΩ or less
White balance adjustment	Automatic	Microphone jack	Mini jack, -64 dBs For low-impedance microphone
Minimum subject illumination	7 lux		
Subject illumination range	7 lux~100,000 lux		
Recommended subject illumination	300 lux or more		

*specifications and external appearance are subject to change without notice.

BASIC RECORDING TECHNIQUES

With just a little practice, you can acquire the basic techniques for fine recording results. With this unit you can record a scene over and over until you're satisfied.

Holding The Camera

Usual recording posture



Using a tripod

The use of a tripod is suggested in order to prevent "jitter" caused by hand-held instability, particularly for close-up recording.

Picture quality is improved by using a tripod.

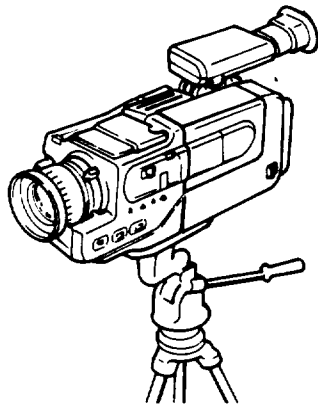

Bottom of this unit.

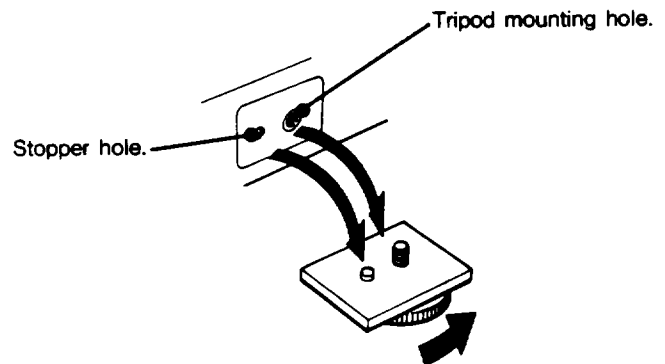

Align this unit's tripod mounting hole and stopper hole with the tripod's screw and turn stopper tighten securely.

Basic Shots

Effective angles and shots make your recordings more interesting.

Human subjects

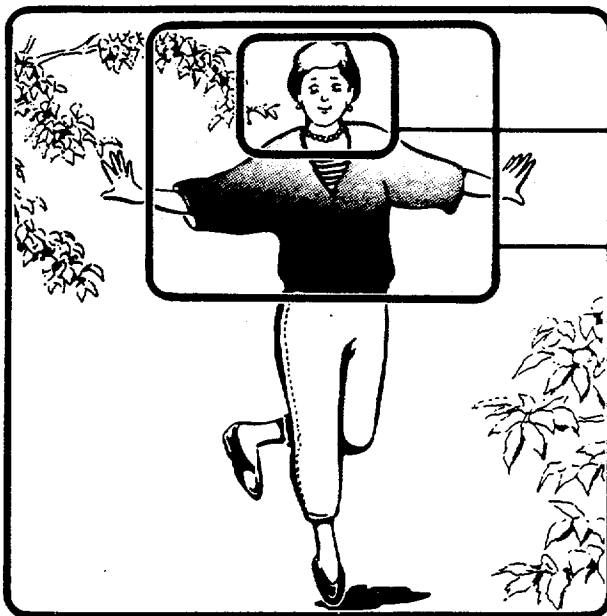

Close-up shots

Close-ups are effective for emphasizing a certain part of the subject.

Bust shots

This size is excellent for showing both the facial expression and clothing.

Full-length shot

The full-length shot shows the subject entirely, as well as a clear view of the background; this is of course very effective to show overall body movement.

Scenic shots

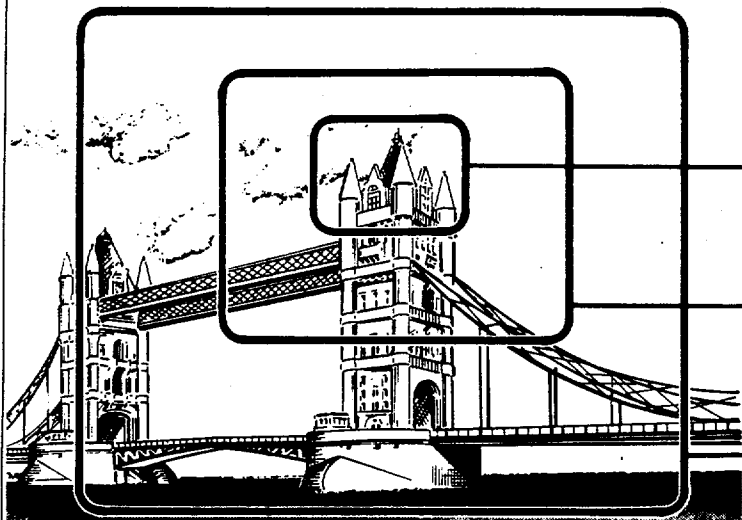

Close-up

This type brings the subject close, and is very effective for emphasis.

Mid-range

This range is the basic range from which you'll zoom in or zoom out for wide-angle shots.

Long range

The most effective range for showing surrounding conditions and to express a sense of distance.

Panning/Tilting

Panning

Moving laterally ... to shoot the overall view and to express a sense of dimension
A steady posture is important for wide-angle shots in order to prevent vibration of the picture

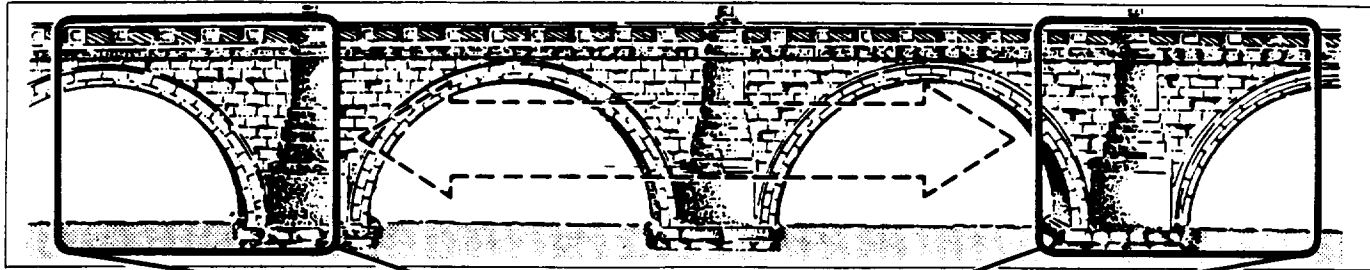

1 Fix your body in the direction you want to face at the end of the shot. Then twist the upper torso to face the camera in the direction where you'll begin the shot.

2 Shoot the first scene for about three seconds.



3 Turn your body slowly while shooting, until you are facing in the direction where the shot will end.

4 Shoot the final scene for about three seconds.

Tilting

Moving up and down ... to show the height of the subject

Tilt (pan) upward when you want to emphasize the height of the subject.

Tilt (pan) down for a scene in which the subject is coming out from a building.

Tilting (vertical panning) should usually be at a somewhat faster speed than horizontal panning.
Support your back to make shooting easier.

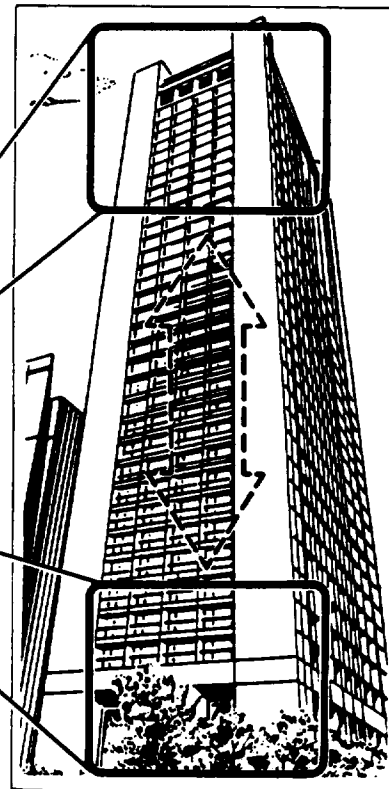
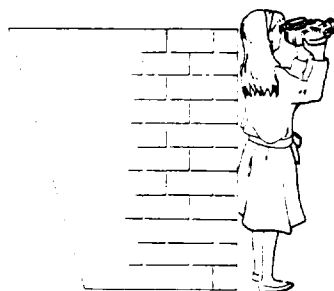

Zooming

You may be able to change the picture smoothly from a wide angle picture in which you can comprehend the circumstances and position of the surroundings of the object to the picture of a close-up of a special section of the object. When too many zoomings are performed, they tend to become unsightly.

Zoom-in. . . . To call attention to a specific point.

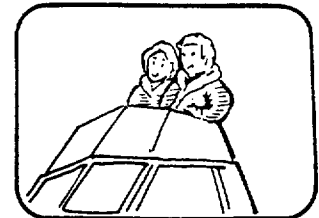
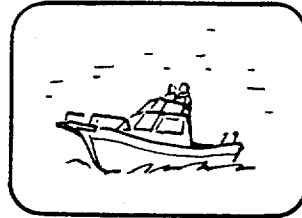
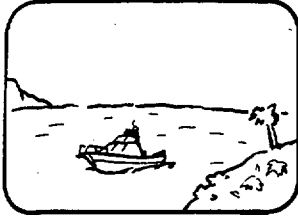

Zoom-out. . . . To include a final shot of the surrounding scene.

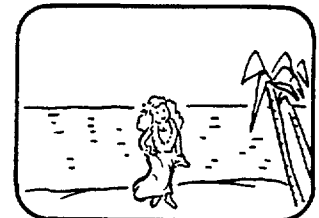

Note:

- Vibration is more noticeable in telephoto shots, so be sure to keep the camera steady.
- When using the manual focus for zooming, first adjust for correct focus at the telephoto setting and then make the zoom. The scene will be blurred if it is zoomed-in after the focus is made at wide angle.

Lighting Conditions and Lights

An important point for the best results is correct lighting conditions. Use the table below as a reference for the most suitable lighting conditions.

ND filter is recommended	Unit (lux)	Snow-covered mountains
		Ski slopes
	100,000	Beach on clear summer day
		Clear-sky sunlight at noon (100,000)
		Clear-sky sunlight at 3 PM (35,000)
		Cloudy-sky sunlight at noon (32,000)
Usable range	10,000	Cloudy-sky sunlight one hour after dawn (2,000)
	1,000	Next to window in office with fluorescent lighting (1,000)
		Clear-sky one hour before sundown (1,000)
	500	Inside a department store (500 to 700)
		Ticket gate of a train station (650)
		Office with fluorescent lighting (400 to 500)
		13-m ² (43-ft ²) room with two 30-W fluorescent lights (300)
		Subway platform (300)
Additional lighting is suggested	100	Shopping arcade at night (150 to 200)
		Inside movie theater at intermission (15 to 35)
Additional lighting needed	10	Candlelight (10 to 15)

When shooting outdoors (natural lighting)

Select camera position as though carrying the sun on your back. In this way, the sun shines on the object evenly and enables shooting of lovely pictures.

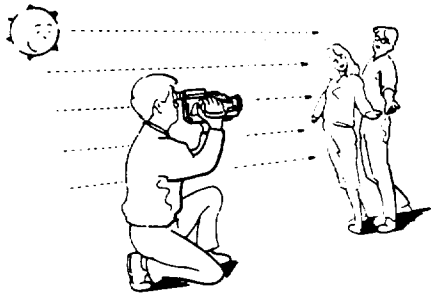

For a scene on which there is excessive light, such as a beach or a snow scene on a bright day, the scene will appear too white, so an ND filter should be used to reduce the amount of light. The ND-4 filter will usually perform satisfactorily in most circumstances. (filter size 49 mm)

When shooting indoors (artificial lighting)

Pictures may be shot with only fluorescent lamps but more distinct pictures are obtained if the object is brighter.

Directing the lights

For one light:

The light should basically be directed diagonally from the front. With a single light, the contrast will always be strong. Use another light if you want to get rid of the shadows.

For two lights:

Direct one diagonally from the front, and position the other at the side of the subject to eliminate any shadow.

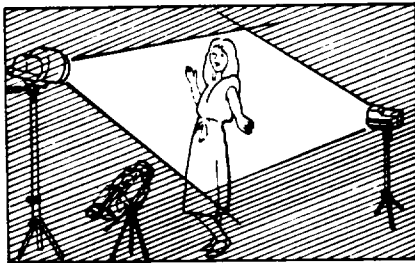

Types of lights

Reflector flat light

The light will be spread over a wide range, making this an easy and convenient type of light for the beginner to use.

Reflector Spotlight

This type of light can be used to emphasize a certain point, and to create special lighting effects.

Note:

- Do not place this unit near a light or where it will be directly struck by light. The light's heat might deform this unit's exterior.

The Personal Touch

Once you have mastered the techniques of the video camera, you can go on to create works, which bear your own individual touch.

1. Planning a script

The best work you'll do, if a story is involved, will be done with the help of a script that you've prepared in advance to plan every step and the sequence. A list of 6 easy questions (Who, What, When, Where, Why, How) helps you plan the progress of your story. Below you can see a story board script in which sketches were included.

2. Making titles

Your use of titles adds extra interest, flavor and the "professional touch", in the same way as films shown in theaters and on TV.

3. Start recording

Begin shooting scenes based on your prepared script.

