

**ASAHI  
PENTAX**

**SMC  
PENTAX LENSES**

**K**

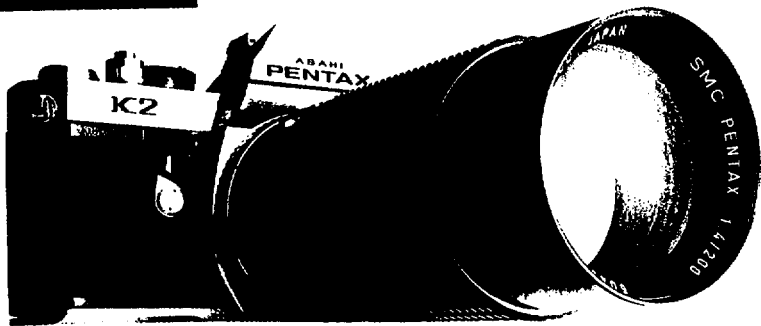

## CONTENTS

Handling lenses .....	4	Mirror lock-up device .....	19
Lenshoods .....	6	Tripod seat ring .....	20
Square hoods .....	6	Steady tripod .....	20
Round hoods .....	8	Macro lenses .....	21
Built-on hoods .....	10	Zoom lenses .....	22
Filters .....	12	Depth-of-field table .....	24
Screw-in filters .....	12	Depth-of field scale .....	28
Built-in filters .....	13	Focusing distance shift for infra-red photography .....	30
Rear-mount filters .....	15	Lens care .....	31
SMC filters .....	15	Specifications .....	33
Focusing wide-angle lenses .....	16	Warranty policy .....	34
Telephoto lenses .....	18		
Camera holding .....	18		
Shutter speed for hand-held camera .....	19		

## Handling Lenses

---

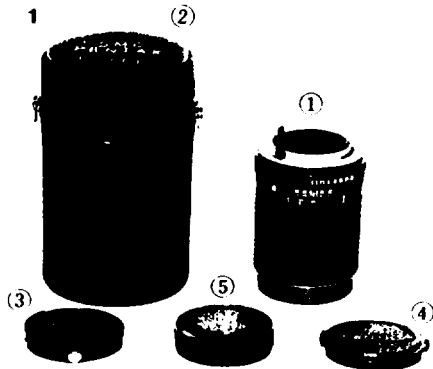

Every SMC Pentax lens (1), except for the 1000mm and 135-600mm zoom lenses, is supplied with a leather lens case (2) and a shoulder strap (3). The shoulder strap, which is fastened to the lens case in the same manner as to a camera case, offers you the convenience of carrying the lens case over your shoulder. If the lens case is to be kept in a camera bag, it may be more convenient to take off the shoulder strap.

In addition, the SMC Pentax lens is furnished with a lens cap (4) and a lens mount cap (5), both of which protect the lens against dust, dirt

---

and moisture; be sure to keep these caps on the lens while not in actual use. It is a good practice to place these caps, whenever removed from the lens, in the leather lens case so that they will not be lost.

The lens case is large enough to hold a lens with a filter (except for a polarizing one) attached; in this case, the focusing ring has to be set at infinity to minimize the length of lens. When the lens has been removed from the camera body, place it front down as shown in Fig. 1. Don't place the lens on its side because

it may roll. Nor is it recommendable to place the lens on its backend since there is an automatic diaphragm lever protruding from this end.

A standard lens, when removed from the camera body, should be kept in a standard lens case for protection. This case is available as an optional accessory.

Be careful never to touch the lens surface with your fingers. Lens stains such as fingerprints are difficult to wipe off.

## Lenshoods

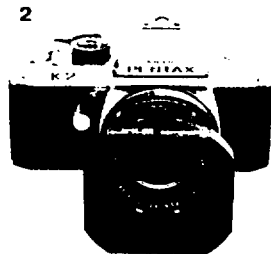

Lenshoods are classified into three types: (1) square hoods for standard and wide-angle lenses, (2) round hoods for standard and telephoto lenses and (3) built-on hoods for super-telephoto lenses.



---

### Square hoods

---

There are 3 sizes of square hoods available, one each for the following groups of SMC Pentax lenses:

- (1) 20mm f/4 and 24mm f/3.5
  - (2) 28mm f/3.5, 35mm f/2 and 35mm f/3.5
  - (3) Standard lenses
-

---

Because of the rectangular picture format, square lens hoods are better suited to 35mm cameras than round hoods. However, a square hood must be re-positioned every time you switch from horizontal to vertical format, or vice-versa.

Like lens caps, square lenshoods are held in place by means of a spring, and are attached to the front frame of the lens by depressing the knobs (6) on either side of the front frame. (See Fig. 3)

3

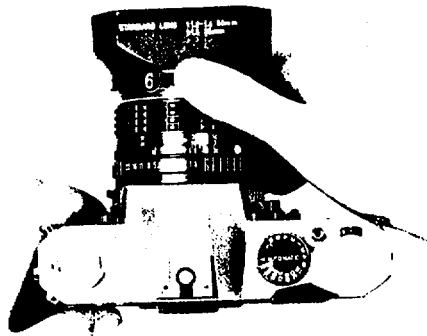

---

### Round Hoods

Round lenshoods also have a spring and are attached in the same manner as square ones.



---

### Round Hoods

There are 5 sizes of round hoods available, one each for the following groups of SMC Pentax lenses:

- (1) Standard lenses
  - (2) 85mm f/1.8, Macro 100mm f/4 and 105mm f/2.8
  - (3) 120mm f/2.8, 135mm f/3.5 and 150mm f/4
  - (4) Zoom 45-125mm f/4
  - (5) 135mm f/2.5, 200mm f/4, Zoom 85-210mm f/4.5
-

---

As shown in Fig. 4, a round hood can be conveniently stored by reversing it over the front of a lens to reduce the overall length. To do this, all filters must be removed from the lens.

4





---

### **Built-on Hoods**

---

Built-on hoods are fixed on the following super-telephoto lenses:

SMC Pentax 300mm f/4

400mm f/5.6

500mm f/4.5

1000mm f/8

Zoom 135-600mm f/6.7

When using this type of hood, simply extend it.

---

#### Notes:

A lenshood can be used with a lens which has a focal length longer than that indicated on the hood, though in such a case its effectiveness will be reduced. On the other hand, a hood

should never be used with a lens of shorter focal length than that indicated, because this will result in part of the picture being blocked. For example, a square hood for the 28mm f/3.5, 35mm f/2 and 35mm f/3.5 lenses can be used with a standard lens. However, the hood for a standard lens should not be used with a wide-angle lens.

Any lenshood can be attached to a lens while a filter (except for a polarizing filter) is also on. The hood for the SMC Pentax Zoom 45-125mm f/4 lens consists of two units. A 67mm filter has to be screwed into the lower frame of the hood; then the upper frame is screwed into the filter.

The SMC Pentax Macro 50mm f/4 lens has its front lens element so far retracted that it requires no lenshood.

5

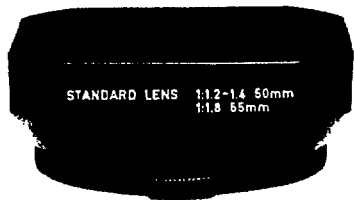

6

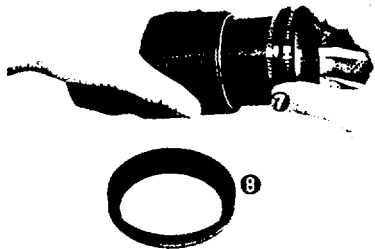

## Filters

Ordinary filters are attached by screwing them into the front end of the lens. There are other filters which are fixed on the rear of the lens and some others which are built into the lens.

Screw-in Filters	Filter Size	SMC Pentax lens
	52mm	Standard lenses, 28mm f/3.5, 28mm f/2 35mm f/3.5, Macro 50mm f/4, 85mm f/1.8, Macro 100mm f/4, 105mm f/2.8, 120mm f/2.8, 135mm f/3.5, 150mm f/4, 500mm f/4.5, 1000mm f/8, Zoom 135-600mm f/6.7
	58mm	20mm f/4, 24mm f/3.5, 135mm f/2.5, 200mm f/4, Zoom 85-210mm f/4.5 (Note: When using the Zoom 45-125mm f/4 lens with a 58mm filter to shoot at the minimum distance of 60-70mm, you might find the picture slightly dark at the corners.)
	67mm	Zoom 45-125mm f/4
	77mm	300mm f/4, 400mm f/5.6

---

#### **Built-in Filters**

Filters are built into the SMC Pentax Fish-Eye 17mm f/4 and SMC Pentax 15mm f/3.5 lenses. In the case of the Fish-Eye, this is because the lens has a wider angle of view than a filter and using a filter would cause vignetting. In the case of the 15mm f/3.5, its front frame diameter is too large to accept an ordinary filter.

The Fish-Eye 17mm lens has four filters built





---

#### **Rear-mount Filters**

The 500mm f/4.5, 1000mm f/8 and Zoom 135-600mm f/6.7 lenses have threads on the back which accept 52mm filters. If these lenses were to use front filters, these filters would be exceptionally large, in size and weight, and would be more expensive to manufacture.

#### **SMC Filters**

SMC filters are available in Skylight, UV, Y2, O2, R2 and Cloudy. They are super-multi-coated to minimize lens reflection and are recommended for use with all Pentax K Series cameras.

**Caution:** The filter forms part of the optical system of the camera. Handle it with the same care you show the lens itself.

## Focusing Wide-Angle Lenses

### 10-1

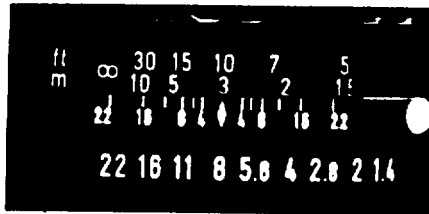

### 10-2

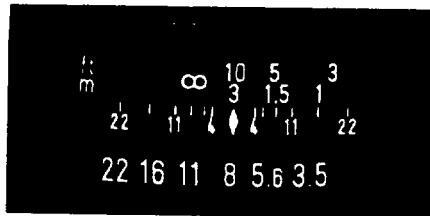

When the lens-to-subject distance is constant, the shorter the focal length, the greater the depth-of-field. Compare the 50mm f/1.4 lens in Fig. 10-1 with the 28mm f/3.5 lens in Fig. 10-2, and you will see how great the depth-of-field difference is between the two lenses. The smaller the depth-of-field, the easier it is to bring into focus. Therefore, you will find it more difficult to focus a wide-angle lens by looking through the viewfinder than to focus a standard focal length lens.

When the aperture ring is set at 5.6 and the distance at 2 meters, there is no necessity for focusing; everything in the distance from 1.5 to 3 meters will be in focus. If the shooting

distance is more than 2 meters, measure this distance visually and set it on the distance scale. Convenient fixed-focus marks for shooting snapshots are provided on the SMC Pentax wide-angle lenses. They're shown as red figures on the diaphragm and distance scales. If you align these figures with the index mark, you do not have to turn the focusing ring every time you want to shoot. The photo (Fig. 11) indicates that the lens diaphragm is set at f/8 and the distance scale at 3 meters. Read the depth-of-field guide, and you will see that this setting affords sufficient focusing sharpness from 1.5 meters to infinity.

11

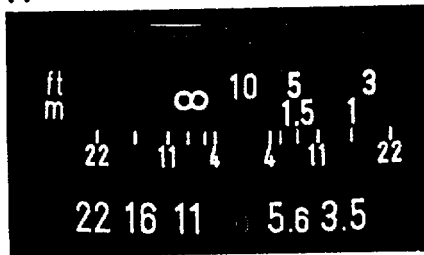



## Telephoto Lenses

---

12



### Camera Holding

Out-of-focus photos are often due to camera movement when the shutter is released. When using a telephoto lens, pay special attention to the way you are holding the camera. Because of the greater length, size and weight and the fact that the center of balance is farther forward, it is even easier for the shutter release to cause camera movement.

As shown in Fig. 12, when using a telephoto lens, the best posture is: left hand extended and supporting both the lens and the camera body, with the thumb and index finger used to rotate the focusing ring. Both elbows should be pressed close to the body, with the upper arms hugging the ribs. If you wear glasses, press them tightly to the frame of the viewfinder window.

---

#### **Shutter speed for hand-held camera**

When using a telephoto lens for hand-held camera work, you should select a faster shutter speed than you might when using a standard lens. The shutter speed which is fast enough to prevent camera movement is said to be  $1/\text{focal length}$ . For example, when using a 135mm lens, you should use a shutter speed of  $1/135$  sec; with a 200mm lens, you should use a shutter speed of  $1/200$  sec. Of course, with experience you will probably be able to use a slower shutter speed and still obtain clear pictures without using a tripod.

#### **Mirror Lock-up Device**

The Pentax K2 and KX are equipped with a mirror lock-up device. If the subject is stationary, you can minimize camera movement by releasing the shutter after locking up the reflex mirror.

13

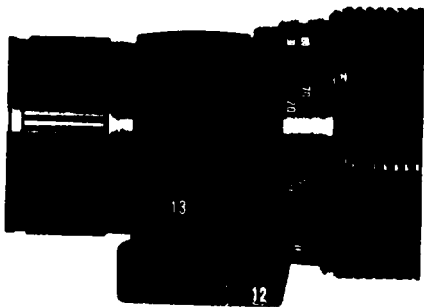

#### **Tripod Seat Ring**

As seen in Fig. 13, lenses longer than 400mm are provided with a tripod seat ring (12) at the proper position on their barrels. By simply loosening the knob (13) on the tripod seat ring, you can easily turn the camera and lens vertically or horizontally.

#### **Steady Tripod**

The 300mm or longer super-telephoto lenses are very heavy. Be sure to select a tripod steady enough to support such a heavy telephoto lens and camera body.

Usually, the weight of the tripod should equal or exceed the weight of the camera body + the weight of the lens x 2. Example: When using a 300mm f/4 super-telephoto lens (942 gr.) with a Pentax K2 body (680 gr.), you should use a tripod whose weight is: 942 gr. + 680 gr. = approx. 1.6 kg. x 2 = approx. 3.2 kg.

## Macro Lenses

---

14

When the magnification index (14) indicates '4', it means that the image on the film is 1/4 as large as the real object. For macrophotography, simply set the desired magnification on the index and then focus by moving the entire camera back and forth.

When using an SMC Pentax Macro lens no particular exposure determination is required. For exposure, you can depend on the meter built into the Pentax K2, KX and KM cameras. You also need not worry about exposure increase factors for close-up work.

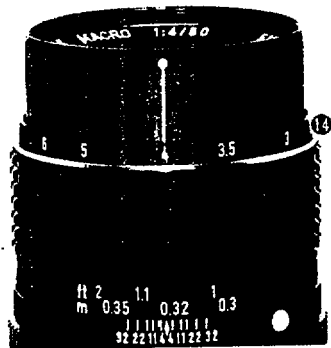

## Zoom Lenses

15

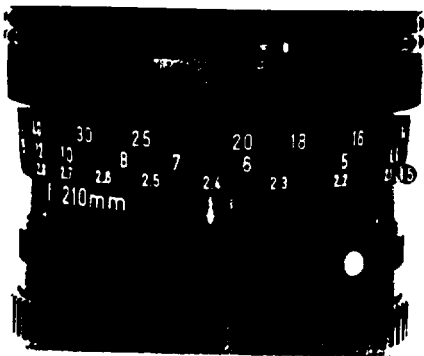

The SMC Pentax Zoom 85–210mm f/4.5 and 135–600mm f/6.7 lenses are furnished with an attachment lens for close-ups. When shooting at a range closer than the zoom lens focusing will permit, use this attachment lens. Focusing is now possible within the range indicated by the white calibration (15) as shown in Fig. 15. Once focused, SMC Pentax Zoom lenses maintain the focus setting even while zooming. It is a good practice to focus at maximum focal length, i.e. with the largest possible image, and then zoom back to the desired field of view. This ensures maximum focusing accuracy.

---

SMC Pentax Zoom lenses have neither a depth-of-field scale nor an infra-red index. When checking the 45-125mm f/4 or 85-210mm f/4.5 lens for focusing sharpness or using them for infra-red photography, see pages 24 through 30.

By nature, zoom lenses give rise to slightly greater distortion (alterations in the shape or proportion of objects) than normal lenses. This distortion varies according to the focal length of the lens. The zoom lens is, therefore, not recommended for situations where proportional accuracy is crucial.

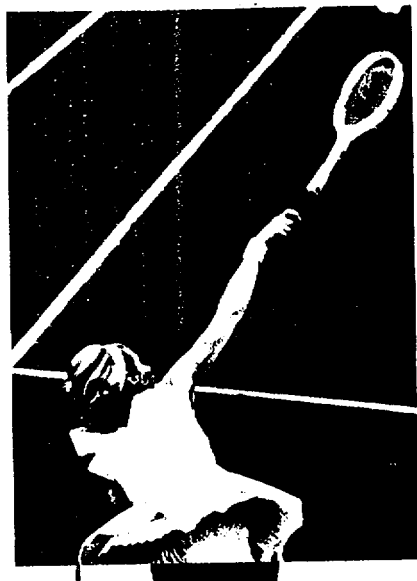

# DEPTH-OF-FIELD TABLE: SMC PENTAX ZOOM 45 – 125mm f/4

Distance scale set at 45mm

(d 0.035mm)

Distance \ Aperture	1.5m	2m	3m	4m	5m	7m	10m	30m	∞
<b>F 4</b>	1.41 1.61	1.82 2.23	2.58 3.61	3.26 5.24	3.87 7.19	4.93 12.5	6.20 27.8	10.3	15.5
<b>F 5.6</b>	1.37 1.66	1.76 2.34	2.45 3.95	3.04 6.01	3.56 8.77	4.42 18.4	5.4 106	8.2	11.
<b>F 8</b>	1.33 1.75	1.68 2.53	2.28 4.60	2.77 7.76	3.18 13.2	3.84 68.5	4.55	6.4	7.9
<b>F 11</b>	1.27 1.87	1.59 2.83	2.10 5.83	2.50 12.4	2.82 38.6	3.3	3.8	5.0	5.9
<b>F 16</b>	1.20 2.14	1.46 3.59	1.86 10.98	2.16	2.39	2.7	3.0	3.7	4.1
<b>F 22</b>	1.12 2.60	1.34 5.35	1.65	1.87	2.03	2.25	2.5	2.85	3.1

Distance scale set at 125mm

(d=0.035mm)

Distance Aperture	1.5m	2 m	3 m	4 m	5 m	7 m	10m	30m	$\infty$
F 4	1.49 ~1.52	1.97 ~2.03	2.93 ~3.07	3.87 ~4.14	4.8 ~5.22	6.6 ~7.45	9.2 ~11.	23.6 ~41.3	108 ~100
F 5.6	1.48 ~1.52	1.96 ~2.04	2.91 ~3.1	3.83 ~4.19	4.72 ~5.31	6.46 ~7.65	8.9 ~11.4	21.7 ~48.7	77.5 ~100
F 8	1.46 ~1.54	1.95 ~2.06	2.87 ~3.15	3.76 ~4.28	4.62 ~5.46	6.25 ~7.97	8.51 ~12.15	19.4 ~66.6	54.3 ~100
F 11	1.45 ~1.56	1.93 ~2.08	2.82 ~3.21	3.67 ~4.40	4.49 ~5.66	6.01 ~8.4	8.06 ~13.2	17.2 ~123	39.5 ~100
F 16	1.45 ~1.56	1.89 ~2.12	2.75 ~3.31	3.54 ~4.61	4.29 ~6.02	5.65 ~9.26	7.41 ~15.5	14.4 ~100	12.1 ~100
F 22	1.43 ~1.59	1.86 ~2.17	2.66 ~3.45	3.40 ~4.89	4.08 ~6.52	5.27 ~10.5	6.77 ~19.7	12.1 ~100	19.9 ~100



# DEPTH-OF-FIELD TABLE: SMC PENTAX ZOOM 85 – 210mm f/4.5

Distance scale set at 85mm

( $d=0.035\text{mm}$ )

Distance Aperture	3.5m	5 m	7 m	10m	15m	20m	35m	80m	$\infty$
F 4.5	3.32 3.72	4.60 5.50	6.20 8.08	8.39 12.5	11.6 21.6	14.3 34.2	20.4 135	30.1	47.6
F 5.6	3.27 3.77	4.51 5.61	6.03 8.40	8.08 13.3	11.0 24.3	13.4 41.5	18.5 459	26.2	38.3
F 8	3.19 3.91	4.33 5.97	5.70 9.20	7.47 15.5	9.85 33.3	11.7 78.3	15.5	20.4	27.
F 11	3.09 4.09	4.13 6.45	5.34 10.5	6.84 19.7	8.76 63.2	10.2	12.9	16.5	19.8
F 16	2.93 4.41	3.84 7.45	4.84 13.7	6.02 36.7	7.42	8.39	10.1	11.9	13.8
F 22	2.78 4.98	3.55 7.3	4.37 22.2	5.28	6.29	6.96	8.07	9.16	10.2

Distance scale set at 210mm

(d-0.035mm)

Distance Aperture	3.5 m	5 m	7 m	10 m	15 m	20 m	35 m	80 m	∞
F 4.5	3.47 3.54	4.92 5.08	6.84 7.17	9.67 10.4	14.3 15.9	18.7 21.6	31.1 40.4	61.8 116	262
F 5.6	3.46 3.55	4.91 5.10	6.81 7.22	9.59 10.5	14.1 16.1	18.4 22.1	30.2 42.0	58.5 120	211
F 8	3.44 3.57	4.87 5.19	6.72 7.31	9.42 10.7	13.7 16.6	17.7 23.1	28.5 45.8	52.4 177	148
F 11	3.42 3.59	4.82 5.21	6.63 7.43	9.22 11.0	13.3 17.3	17.0 24.4	26.6 51.8	46.3 321	108
F 16	3.38 3.64	4.74 5.53	6.47 7.65	8.91 11.4	12.6 18.6	15.9 29.2	24.0 66.1	38.8	74
F 22	3.34 3.69	4.64 5.43	6.29 7.93	8.56 12.1	11.9 20.5	14.8 31.4	21.5 99	33.6	54

## DEPTH-OF-FIELD SCALE

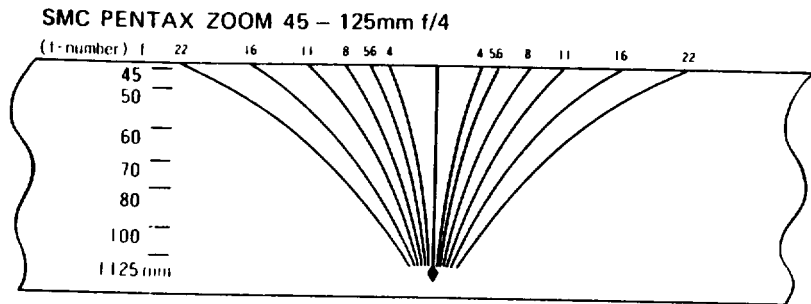

SMC PENTAX ZOOM 85 -210mm f/45.

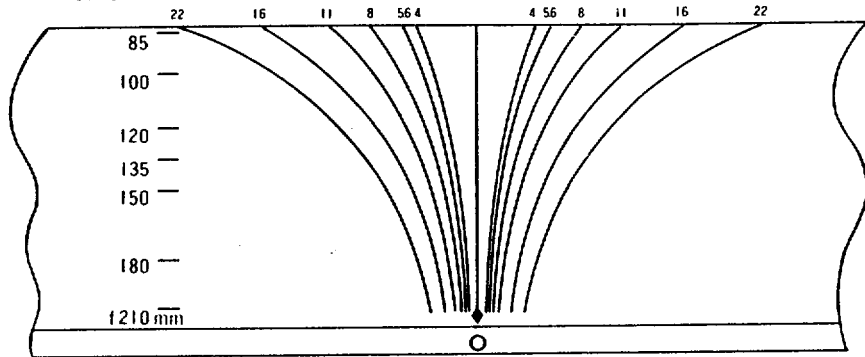

## FOCUSING DISTANCE SHIFT FOR INFRA-RED PHOTOGRAPHY:

SMC PENTAX ZOOM 45 – 125mm f/4

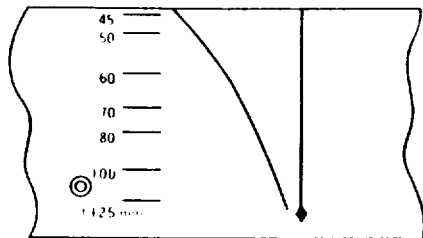

SMC PENTAX ZOOM 85 – 210mm f/4.5

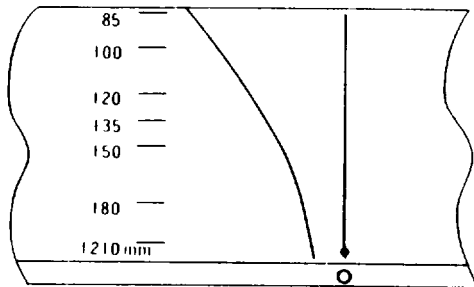

## Lens Care

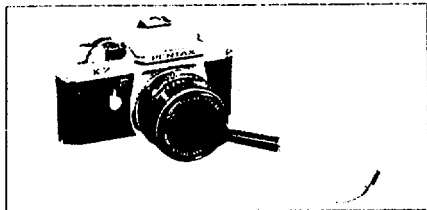

Do not use or store a lens in an extremely damp location, especially where it might be liable to damage by salt spray. It is an excellent practice to protect the lens with a filter, not only at the seashore, but also anywhere that dust or moisture is present. If the lens becomes dirty, do not wipe it with a handkerchief, for it may scratch the surface. Instead, blow away the dirt with a rubber blower and soft brush.

If you touch the lens surface by accident, or if it is too dirty to clean with the blower, use soft tissue paper or very soft cloth, wrapped around

something like a matchstick. This can be dampened with lens cleaning solution or alcohol. Wipe in a spiral pattern, from the center out. For larger lenses, wrap the tissue or cloth around the tip of your finger instead of a matchstick. Be sure to shift the cloth or paper frequently, to avoid wiping with a dirty part. A few wipes over any stained part of the lens should remove the stain. However, if the lens stains cannot be removed this way, take the lens to an authorized Pentax Service Center for professional servicing.

Moisture and dust are not the only things which might damage a lens. Heat, shock and scratches can also be harmful. Be very careful not to bump or drop the lens, and never put it in its case without its protective caps. The wisest practice is to put both the front and rear caps on the lens as soon as it is removed from the camera. If the lens is not used for some time, especially during humid weather, it should be removed from its case at regular intervals and checked for mildew. If any dampness is present, thoroughly dry the case. Light mildew can easily be wiped off.

# Specifications

Type	Name of Lens	Focal length & Maximum Aperture	Minimum Aperture	Less Elements	Diaphragm	mm	fL	Focusing Distance	Angle of View (degrees)	Maximum Diameter	g	oz	Fiber Size (mm)
Fish-eye	● SMC Pentax Fish-eye	17mm f 4	22	11	FA	0.2	0.66	180°	64.5 × 34	234	8.19	151	
Super-wide-angle	● SMC Pentax	15mm f 3.5	22	13	FA	0.3	1.0	111°	80 × 81.5	550	19.25	131	
	● SMC Pentax	20mm f 4	22	12	FA	0.25	0.8	94°	63 × 57	300	10.5	58	
	● SMC Pentax	24mm f 3.5	22	9	FA	0.25	0.8	84°	63 × 46.5	248	8.68	58	
Wide-angle	● SMC Pentax	28mm f 3.5	22	8	FA	0.3	1.0	75°	63 × 47	271	9.14	52	
	● SMC Pentax	35mm f 2	22	8	FA	0.35	1.2	62°	63 × 56	295	9.9	52	
	● SMC Pentax	35mm f 3.5	22	5	FA	0.35	1.2	62°	63 × 35.5	165	5.64	52	
Standard	● SMC Pentax	50mm f 1.2	22	7	FA	0.45	1.5	46°	65 × 48.5	391	13.48	52	
	● SMC Pentax	50mm f 1.4	22	7	FA	0.45	1.5	46°	63 × 41.5	266	9.28	52	
	● SMC Pentax	55mm f 1.8	22	6	FA	0.45	1.5	43°	63 × 39	221	7.74	52	
Telephoto	● SMC Pentax	85mm f 1.8	22	6	FA	0.85	2.75	29°	64 × 56	331	11.59	52	
	● SMC Pentax	105mm f 2.8	32	5	FA	1.2	4	23°	62.5 × 63	304	10.29	52	
	● SMC Pentax	120mm f 2.8	32	5	FA	1.2	4	21°	62.5 × 74.5	364	12.43	52	

Type	Name of Lens	Focal length & Maximum Aperture	Minimum Aperture	Lens Elements	Diaphragm	m	ft.	Focusing Distance	Angle of View (degrees)	Maximum Diameter	Weight	oz.	Filter Size (mm)
Telephoto	● SMC Pentax	135mm f/2.5	32	6	FA	1.5	5	18"	67.5 × 85.9	483	16.45	58	
	● SMC Pentax	135mm f/3.5	32	4	FA	1.5	5	18"	62.5 × 87.5	365	11.38	52	
	● SMC Pentax	150mm f/4	32	5	FA	1.8	6	17"	62.5 × 96	338	11.83	52	
Super-telephoto	● SMC Pentax	200mm f/4	32	5	FA	2	6.5	12"	65 × 137	532	18.06	58	
	● SMC Pentax	300mm f/4	32	7	FA	4	13	8"	85 × 188	1,020	32.97	77	
	● SMC Pentax	400mm f/5.6	45	5	M	8	27	6"	85 × 277	1,269	43.4	77	
	● SMC Pentax	500mm f/4.5	45	4	M	10	35	5"	126.5 × 440	3,366	116.6	52	
	● SMC Pentax	1000mm f/8	45	5	M	30	100	2.5"	143 × 738	5,294	183.8	52	
Zoom	● SMC Pentax	45 - 125mm f/4	22	14	FA	1.5	5	50.5 - 20"	69 × 127	612	21.42	67	
	● SMC Pentax	85 - 210mm f/4.5	32	11	FA	3.5	12	29 - 11"	67.5 × 217.5	739	25.87	58	
	● SMC Pentax	135 - 600mm f/6.7	45	15	M	6	20	18 - 4"	105 × 582	4,070	142.5	52	
Macro	● SMC Pentax Macro	50mm f/4	32	4	FA	0.234	0.77	46"	63 × 54	247	8.44	52	
	● SMC Pentax Macro	100mm f/4	32	5	FA	0.45	1.48	24.5"	65 × 81.5	370	12.95	52	

● Open-aperture metering lenses. ● Stop-down metering lenses. FA - Fully-automatic. M - Manual. B: -4 filters built-in.



## WARRANTY POLICY

All Asahi Pentax lenses purchased through authorized bona fide photographic distribution channels are guaranteed against defects of material or workmanship for a period of twelve months from date of purchase. Service will be rendered and defective parts will be replaced without cost to you within that period, provided the equipment has not been abused, altered, or operated contrary to instruction. Because the tolerances, quality, and design compatibility of lenses other than Pentax lenses are beyond our control, damage caused by use of such lenses will not be covered by this warranty policy. The manufacturer or its authorized representatives shall not be liable for any repair or alterations except those made with its written consent and shall not be liable for damages from delay or loss of use or from other indirect or consequential damages of any

kind, whether caused by defective material or workmanship or otherwise; and it is expressly agreed that the liability of the manufacturer or its representatives under all guarantees or warranties, whether expressed or implied, is strictly limited to the replacement of parts as hereinbefore provided.

### PROCEDURE DURING 12-MONTH WARRANTY PERIOD

Any Asahi Pentax lens which proves defective during the 12-month warranty period should be returned to the dealer from whom you purchased the equipment or to the manufacturer. If there is no representative of the manufacturer in your country, send the equipment to the manufacturer, with postage prepaid. In this

---

case, it will take a considerable length of time before the equipment can be returned to you owing to the complicated customs procedures required in Japan in importing and re-exporting photographic equipment. If the equipment is covered by warranty, repairs will be made and parts replaced free of charge, and the equipment will be returned to you upon completion of servicing. If the equipment is not covered by warranty, regular charges of the manufacturer or of its representatives will apply. Shipping charges are to be borne by the owner. If your Asahi Pentax lens was purchased outside of the country where you wish to have serviced during the warranty period, regular handling and servicing fees may be charged by the manufacturer's representatives in that country. Notwithstanding this, your Asahi Pentax returned to the manufacturer will be serviced free of charge

according to this procedure and warranty policy. In any case, however, shipping charges and customs clearance fees are to be borne by the owner. To prove the date of your purchase when required, please keep the receipts or bills covering the purchase of your equipment for at least a year. Before sending your equipment for servicing, please make sure that you are sending it to the manufacturer's authorized representatives or their accredited repair shops, unless you are sending it directly to the manufacturer. Always obtain a quotation of the service charge, and only after you accept the quoted service charge, instruct the service station to proceed with the servicing.

This warranty policy does not apply to Asahi Pentax lenses purchased in the U.S.A. For these lenses, please refer to the separate Warranty Policy Card enclosed here.





**ASAHI OPTICAL CO., LTD. C.P.C. 895, Tokyo 100-91, JAPAN**

**ASAHI OPTICAL EUROPE N.V. Weveldlaan 3-5, 1930 Zaventem, BELGIUM**

**ASAHI OPTICAL EUROPE S.A. (Hamburg Office) 2000 Hamburg 54 (Lokstedt), Grandweg 64, WEST GERMANY**

**ASAHI OPTICAL (AMERICA) INC. 15 East 26th Street, Suite 1710, New York, New York 10010, U.S.A.**

**ASAHI OPTICAL BRASILEIRA IND. E COM. LTDA. Rua Estados Unidos, 1053, São Paulo, SP, BRASIL**

Printed in Japan