

**PENTAX®**

***IQZ*oom**

***IQZ*oom DATE**

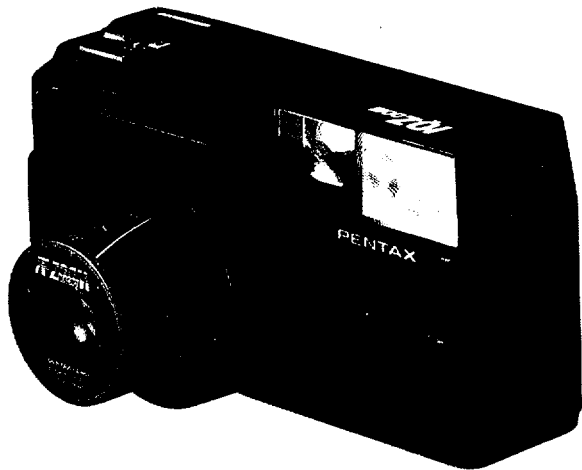

## Main switch and LCD window's displays

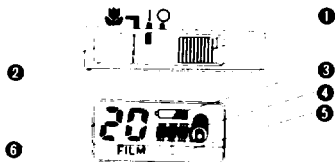

- 1 Main switch: To operate the camera, turn this switch on by setting it as shown above.
- 2 Macro-focus-set button: When shooting in the macro mode, align the main switch with the  mark while pushing this macro-focus-set button.
- 3 Battery mark: This mark lights up when the battery gets weak.
- 4 Cartridge mark: When film is loaded into the camera and the back cover is closed, this mark appears, and it also flickers when the film rewinding is completed.
- 5 Film-transport mark: This indicates the film is being wound or rewound.
- 6 Exposure counter: This indicates how many pictures were taken.

## CAUTIONS

- This camera is powered by one 6V lithium battery (BR-P2 or DL-223A), or four "AAA" size alkaline batteries. The Ni-Cd battery is not compatible.
  - The lens protector automatically opens or closes by turning the main switch on or off. Do not open it manually.
  - When film is not in the camera, flash does not fire, nor does the cartridge mark appear in the LCD window, nor does the macro function work.
- The shutter cannot be released if or when:**
- the battery is not in the camera or it is incorrectly inserted in the chamber, or it is exhausted.
  - the main switch is off.
  - you shoot a subject more than one meter (3.3 ft.) away, with the lens set in the macro mode.
  - the lens is in the zooming action.
  - the flash is being charged, or the recycle time becomes much longer than usual.
  - the film is being rewound, and the film rewind has just been completed.

# NAMES OF WORKING PARTS

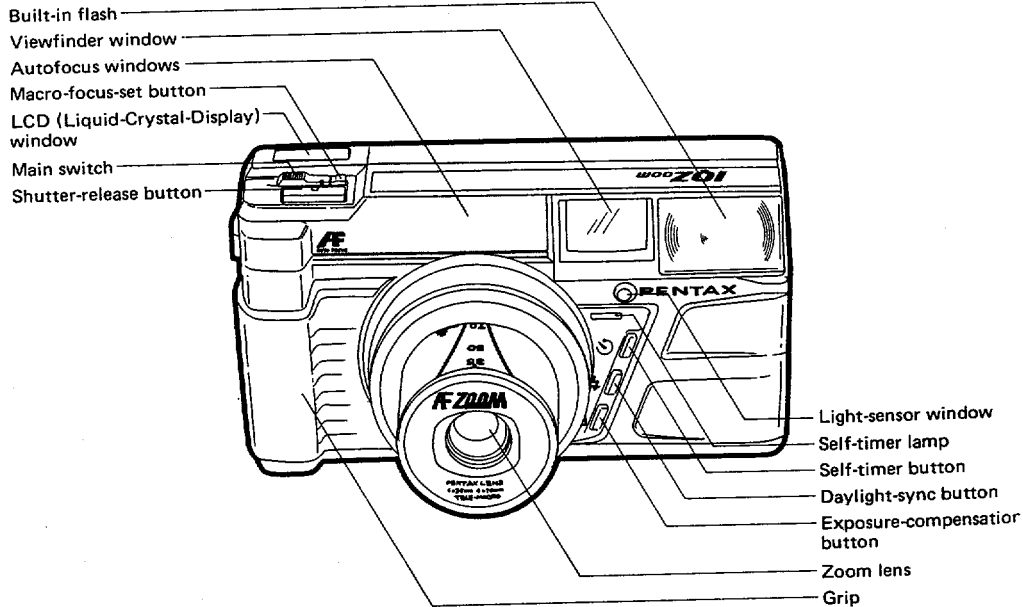

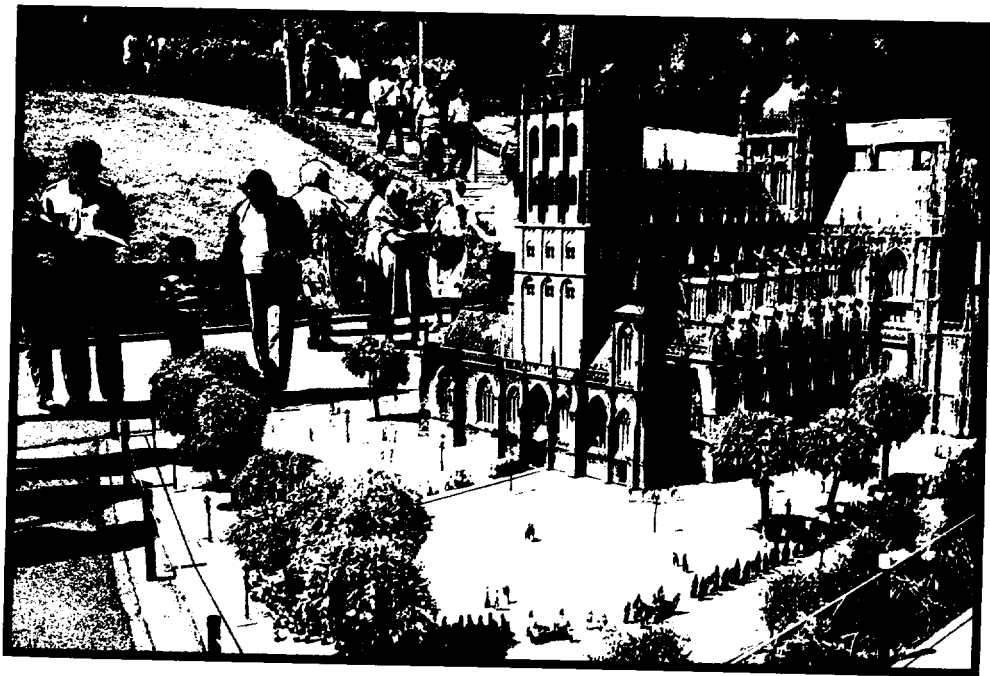

Thank you very much for choosing the world's first fully automatic 35mm leaf-shutter camera to integrate a macro-to-telephoto power zoom, zoom finder and zoom flash. The camera's auto-focus, auto-exposure, auto-film-speed-setting, auto-film-loading, auto-winding, auto-rewinding and auto-flash controls will certainly help you enjoy fine photography with memorable results just easily and flawlessly. Moreover, if you own the DATE model, you will always be able to remember when you took all the pictures.

Needless to say, your camera is a sophisticated, precision instrument built to give long-lasting, reliable service, and will serve you well if you treat it right, with proper handling and reasonable care.

Please read this manual carefully to familiarize yourself with all the features and functions it has to offer.

## CONTENTS

---

Battery insertion and check .....	2-3
Film .....	4
Loading film .....	5-7
Camera holding.....	8
Operating 35 - 70mm Zoom lens .....	9
Taking general pictures .....	10-11
Unloading film .....	12
Effective picture-taking range.....	13
Taking close-up pictures (Macro shooting)...	14-15
Flash photography.....	16-17
Focus-lock shooting .....	18-19
Exposure compensation.....	20
Self-timer .....	21
IQ Zoom DATE .....	22-25
Strap and soft case.....	26
Battery .....	27
Taking care of your camera.....	28-29
Specifications .....	30-31
Warranty policy .....	32

## BATTERY INSERTION AND CHECK

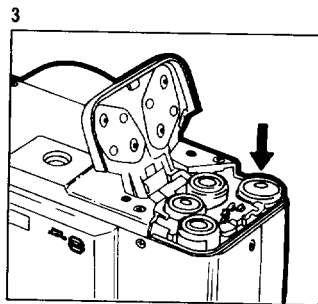
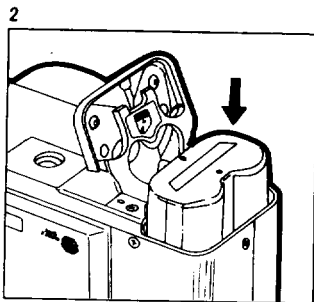
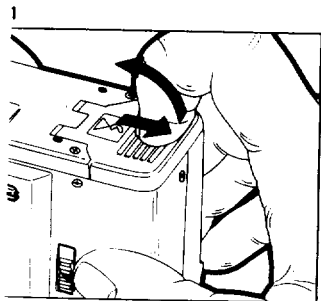

This camera is powered by one 6V lithium battery pack (Panasonic/National BR-P2, CR-P2p or Duracell DL-223A), or four "AAA"-size alkaline batteries.

• Manganese batteries can also be used, but they have far less power than the lithium or alkaline batteries.

1. Open the battery-chamber cover by pushing and raising it in the direction of the arrow. To insert the lithium battery, open the inside cover as well.
2. Insert the lithium battery pack into the chamber correctly as indicated on the inside cover, and close the two covers.
3. When using alkaline batteries, first fold down the alkaline battery guide plate and insert the batteries through the guide's holes making sure the (+) and (-) sides are correctly placed as indicated on the guide plate. Do not remove the plastic tabs/ears in each battery guide hole as they keep the batteries securely in place.

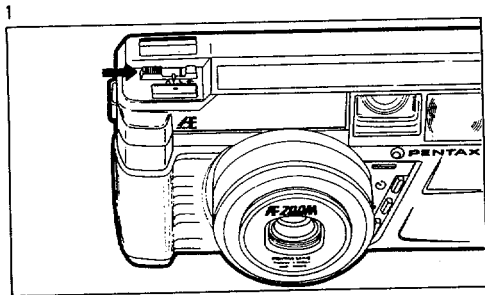

### 1. Battery check

As you turn the main switch on, the lens slightly extends, and the lens protector opens. If they do not, the battery is exhausted, or it is not properly loaded.

Do not remove the battery from the camera which is operating; otherwise it may malfunction.

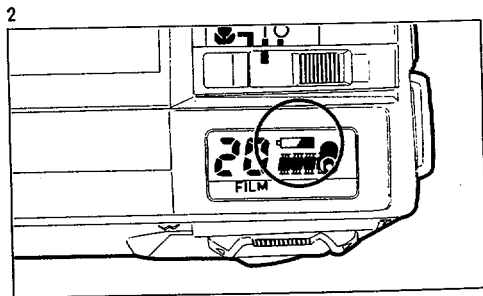

### 2. Battery replacement

If the battery mark in the LCD window is lit up while you are operating the main switch, the zoom lever, or the shutter-release button, the battery is becoming exhausted, and it should be replaced with a new one. When the battery power is getting low, reaching the limit of use, the battery mark is lit up, then flickers, and the shutter cannot be released. When the battery is completely exhausted the battery mark does not even appear.

## FILM

### DX FILM

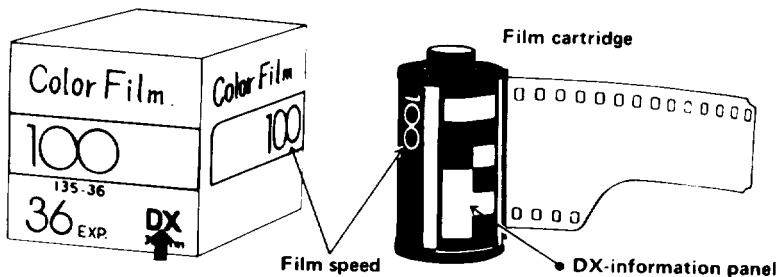

This camera is designed to use DX-coded film with an ISO rating from 50 to 1600, and when such film is loaded, its film speed is automatically set in the camera.

- If non-DX film is loaded by mistake, the film speed is automatically set to ISO 100, no matter what the film speed is.
- When high-speed film with an ISO rating of over 1600 is loaded into the camera, the film speed is automatically set to 1600.
- Special films like 35mm Instant Reversal Film cannot be used.
- If a wide-angle picture is taken in a very bright place outdoors using high-speed film, it tends to be overexposed. Use such film indoors or in a dark place.



## LOADING FILM

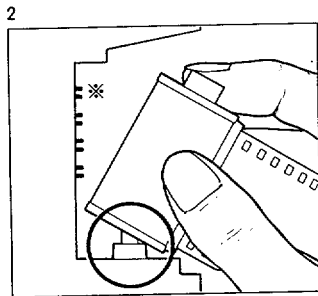
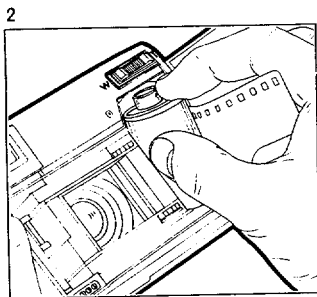
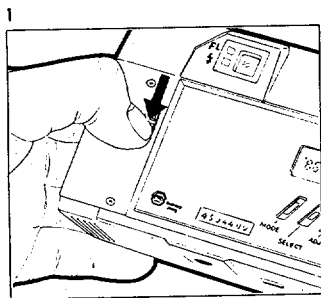

Always load or unload film in a shady spot, or shield the camera and film from direct sunlight with your body.

1. Open the back cover by sliding the back cover release lever in the direction of the arrow.

2. As illustrated, place the film cartridge in the film chamber by first fitting its flat side on the top of the rewind shaft.

- Take care not to put dust, stains or scratches on the lens while loading the film.

- ※ Always keep the DX-Information pins free from scratches, dirt or dust.

3

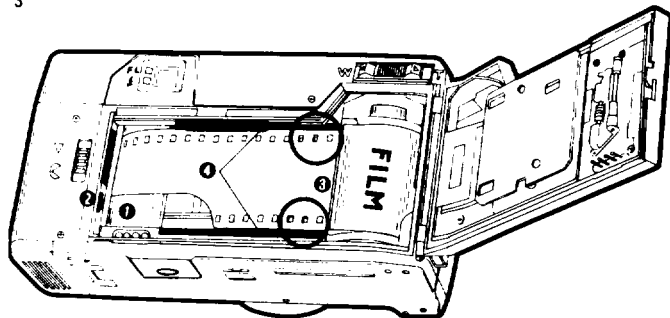

3. Pull the film leader out far enough to reach the ❶ film roller.

- Align the end of the film leader with the ❷ film leader end mark.
- Make sure the film perforations engage the ❸ sprocket teeth properly.
- Also make sure the film is properly placed between the ❹ guide rails.

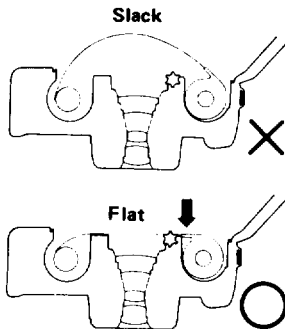

• Make sure the film is taut as shown above; if slack, it may not be loaded properly.

6

4

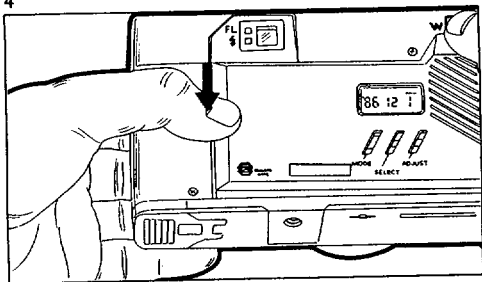

4. Close the back cover, and the film will automatically be wound and advanced to the first frame. (Even without film in the camera, the motor will work for about one or two seconds as you close the back cover.)

● If neither exposure counter nor cartridge mark appears in the LCD window, probably the film has not properly been set in the camera; in such a case, reload the film.

5

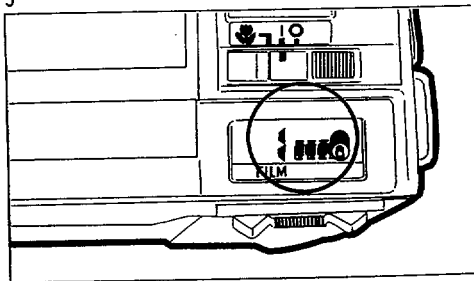

5. The cartridge mark appears in the LCD window and the film-transport mark flickers as the film is wound. When the exposure counter is set to "1," the film winding stops automatically, with the LCD window showing as above.

**Caution:** Even when you wish to remove the film from the camera before taking the first picture, take the normal rewinding procedures described on page 12, without manually removing the film leader from the take-up spool.

## CAMERA HOLDING

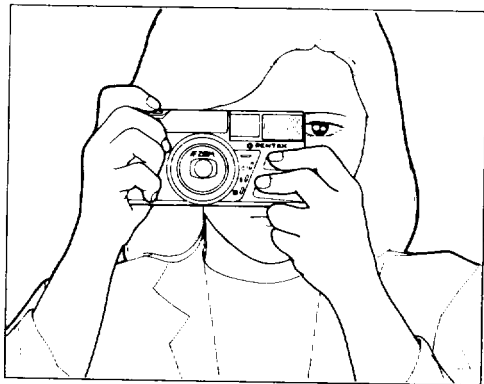

It is important to hold the camera properly in order to take blur-free photos. Practice holding and operating the camera before inserting your first roll of film.

The illustrations show the basic holding positions. No matter which position you use, be sure to grip the camera steadily with both hands, hold the camera gently against the face in a fixed position, and relax the rest of your body in

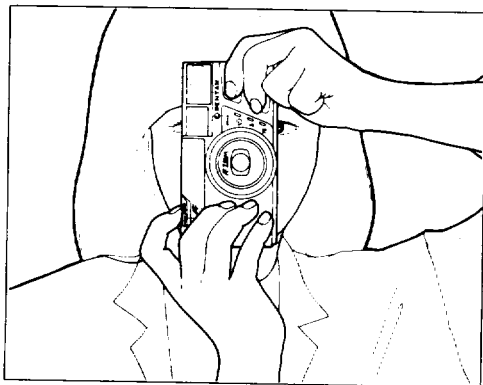

a secure posture. Brace the elbow of the arm supporting the camera against your body. Always press the shutter button gently. When taking flash pictures with the camera held vertically, be sure to keep the flash head on the upper side. Do not hold the zoom lens while shooting because it moves back and forth.

## OPERATING 35 - 70mm ZOOM LENS

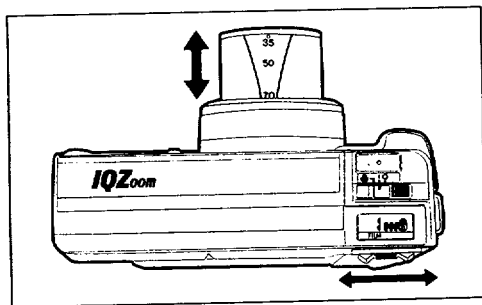

As you turn the main switch on, the zoom lens automatically moves to be set at the wide-angle (35mm) position. As you slide the zoom lever toward "T" (telephoto side), the lens moves to the 70mm telephoto side, enabling you to take a picture of a distant object on a large scale. On the contrary, as you slide the zoom lever toward "W" (wide-angle side), the lens returns to the wide-angle side. While looking through the viewfinder, keep sliding the lever to either side until your desired composition is made, and then release the shutter.

- The shutter cannot be released when the lens is in the zooming action.

35mm



70mm



## TAKING GENERAL PICTURES (Effective Range: one meter (3.3 ft.) ~ ∞)

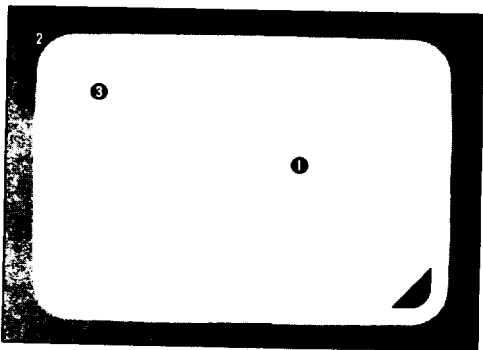

When the lens is on the wide-angle side, part of the lens frame is seen through the viewfinder, but it is not recorded on the film. ↑

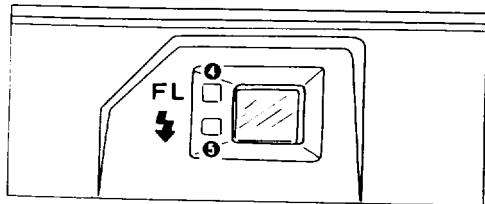

- 1 Autofocus spot (Bring this on the main part of the subject.)
- 2 Picture-area frame (Ordinary picture-taking area)
- 3 Parallax-correction frame (Since the picture area becomes slightly narrow in the macro shooting or in the general-picture shooting of the subject about one meter (3.3 ft.) away, compose the picture within this frame.)

Depress the shutter-release button half-way, and after making sure the green lamp 1 or red one 3 shown at left lights up, release the shutter. If the film is not in the camera, these lamps will not light up properly as follows:

- 1 Green lamp:
    - . When it lights up, you are ready to shoot.
    - . When it flickers, you should not shoot.
  - 3 Red lamp:
    - . When it lights up, flash is ready to fire.
    - . When it flickers, flash is being charged.
- The flickering of the green lamp indicates the camera-to-subject distance is beyond the effective range in the general-picture shooting or in the macro shooting. In this case, adjust the camera-to-subject distance so that the green lamp lights up, and release the shutter. (When the camera-to-subject distance is extremely short, the green lamp may not flicker.)

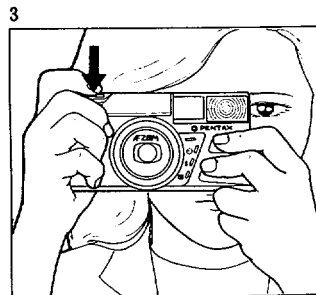
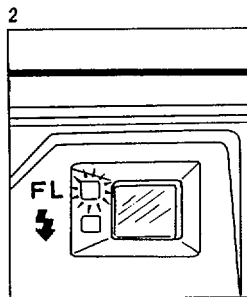

**When shooting, be sure to turn the main switch on.**

1. Compose the picture by sliding the zoom lever, and bring the autofocus spot  on the main part of your subject.
  - Be careful not to block the autofocus windows, lens, light-sensor window, and flash head with your fingers, hair, etc. while you are shooting.
2. When the green lamp next to the viewfinder eyepiece lights up with a slight pressure on the shutter button, you are ready to take a picture. If the green lamp flickers, it warns that the

camera-to-subject distance is too short. Make the distance a little longer.

- When the red lamp lights up, the camera is automatically switched to flash photography.
3. As you depress the shutter button further, the shutter will be released, and the film will be automatically advanced to the next frame.
    - When you change the subject to shoot, release your finger from the shutter button, and redepres the shutter button.

## UNLOADING FILM

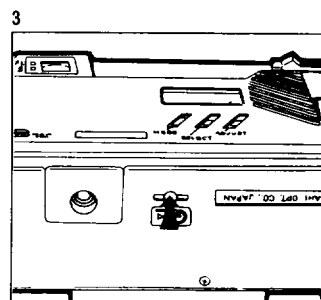
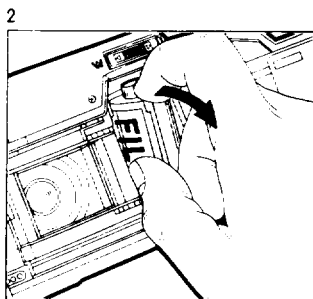
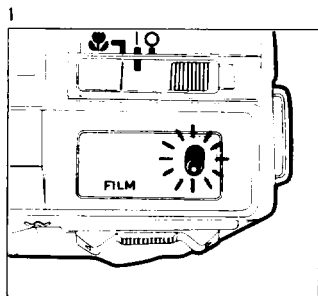

1. Soon after you reach the end of the roll, the motor is automatically activated to start rewinding the film. While the film rewind is taking place, the film-transport mark in the LCD window flickers, and simultaneously the exposure counter is automatically reset. When the rewind is over, the motor stops and the cartridge mark flickers.

- It takes about 35 seconds to rewind a roll of 24-exposure film.
- Never open the back cover until the motor stops.

2. Open the back cover, and remove the film cartridge from the chamber by pulling its top portion with your finger as shown.

3. If you wish to rewind the film in midroll, push the auxiliary rewind button with your fingernail, and the motor will be activated to start rewinding the film; you can then release your fingernail from the button. When the rewind is over, the motor stops.



## EFFECTIVE PICTURE-TAKING RANGE

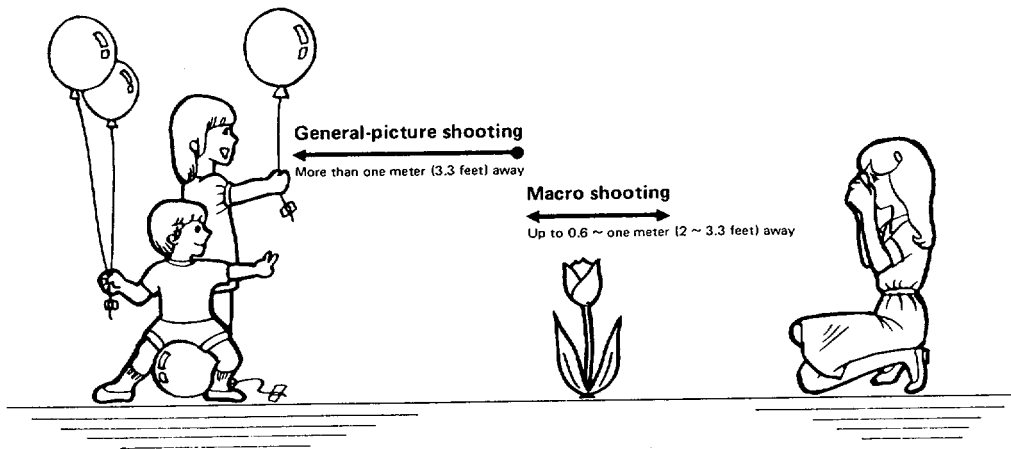

- Take general pictures in the range from one meter (3.3 feet) to infinity ( $\infty$ ).
- Take close-up pictures of the subject which is 0.6 ~ one meter (2 ~ 3.3 feet) away.
- The lens does not focus on the subject which is less than 0.6 meters (2 feet) away from the camera.

## TAKING CLOSE-UP PICTURES (MACRO SHOOTING)

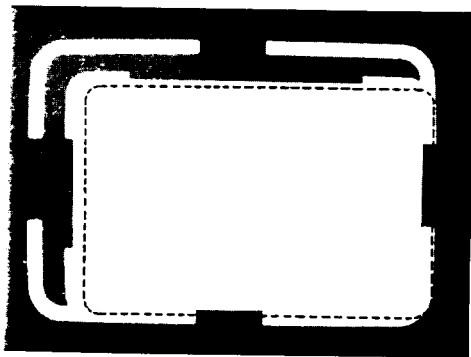

When the lens is set for macro shooting, the area surrounding the picture-area frame in the viewfinder turns green, indicating that you are ready to shoot in the macro mode.

- When the camera-to-subject distance is near 0.6 meters (2 feet), the picture area slightly moves. Therefore, use the area within the red-dotted line as a guide.

14

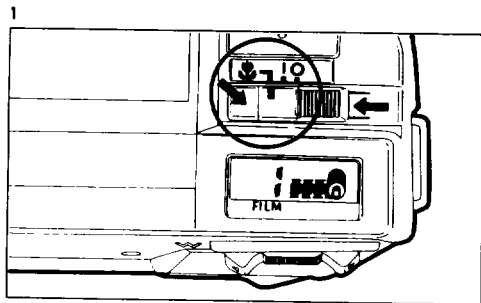

1. Align the main switch with the macro-focus index while pushing the macro-focus-set button, and the lens will move forward and automatically be set for macro shooting. To cancel the macro setting, return the main switch to the ON-position.

- In this type of photography, the autofocus spot does not position in the center of the picture area, so please use the focus-lock technique (pages 18 – 19) and shoot after making a composition.

2

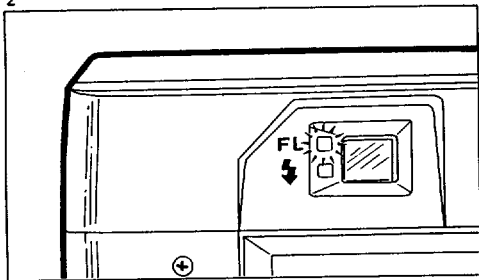

2. The effective camera-to-subject distance is 0.6 ~ one meter (2 ~ 3.3 feet). Depress the shutter button half-way, then make sure the green lamp is lit, and release the shutter. (The lamp does not light when film is not in the camera.)

- If the green lamp flickers, it is a warning that the camera-to-subject distance is too short or too long. (Note that when the distance becomes as short as about 0.3 meters, the lamp will stop flickering and light up solidly.)
- If your subject is more than one meter (3.3 feet) away, the green lamp flickers and at the same time the shutter cannot be released.



## FLASH PHOTOGRAPHY

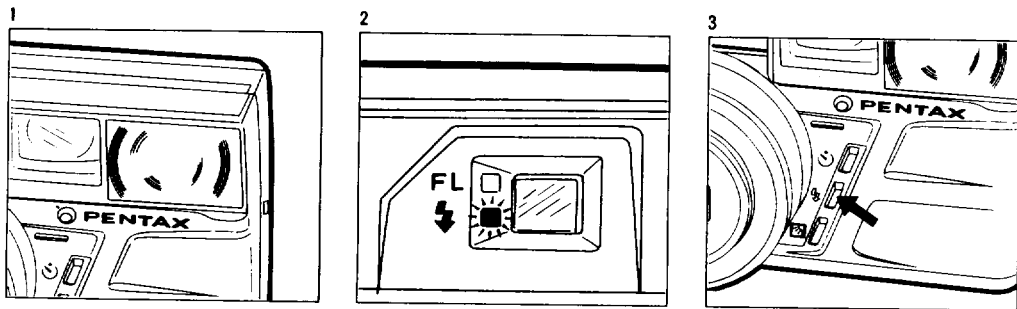

As you depress the shutter button half-way in a dark or dimly-lit place, the camera is automatically switched to flash photography. For the flash-effective range, refer to the table on the next page. When taking a picture of a person in the shade of trees in the daytime, or in the dusk, you can use this camera's flash as a supplementary light.

1. As you depress the shutter button half-way, the red lamp next to the viewfinder eyepiece begins to flicker, indicating the flash is being charged.
2. When the red lamp has stopped flickering, redepres the shutter button half-way, and after

making sure the red lamp lights up (which indicates the flash is ready), release the shutter. The flash will start charging for the next shot.

3. When making daylight-sync flash (fill-in flash), depress the shutter button half-way while pushing the daylight-sync button ( ⚡ ), then make sure the red lamp lights up, and finally release the shutter.

### CAUTIONS

- When the daylight-sync flash is used as a supplementary light, the effect of flash differs more or less, depending on how bright the available light is or how long the camera-to-subject distance is.

### Flash-effective range

Lens \ ISO	50	100	400	1600
35mm (W)	1 – 3.5 m (3.3' – 11.5')	1 – 5 m (3.3 – 16.4')	*1 – 10 m (3.3' – 32.8')	*2 – 12.8 m (6.6' – 42')
70mm (T)	1 – 2.3 m (3.3' – 7.5')	1 – 3.3 m (3.3 – 10.8')	1 – 6.7 m (3.3' – 22')	1 – 12.2 m (3.3' – 40')
Macro	0.6 – 1 m (2' – 3.3')	0.6 – 1 m (2' – 3.3')	0.6 – 1 m (2' – 3.3')	*0.8 – 1 m (2.6' – 3.3')

\*The film speed is so high that shooting at close distances may result in overexposure.

- To take a properly-exposed flash picture, be sure to shoot the subject which is in the flash-effective range shown in the table above.
- Even when the green lamp lights up, overexposed pictures will be taken when the subject is too close to the camera to be in the flash-effective range, or underexposed pictures will be taken when the subject is too far away to be in the flash-effective range.
- Taking flash pictures of people in the dark can cause "red eyes," those red dots in the eyes. This is because the flash light enters the eye and reflects back to the lens from the retina of the eye, and the light will be colored red from the blood vessels in the eye. To avoid this, ask the people not to look directly at the flash.

### Battery life

Battery \ Film	One 6V lithium	Four AAA-size alkaline
24-exposure	Approx. 22 rolls	Approx. 14 rolls
36-exposure	Approx. 14 rolls	Approx. 9 rolls

(When flash photography and non-flash shooting are made on a 50–50 basis, with fresh batteries and at normal temperatures and humidity.)



## FOCUS-LOCK SHOOTING (FL)

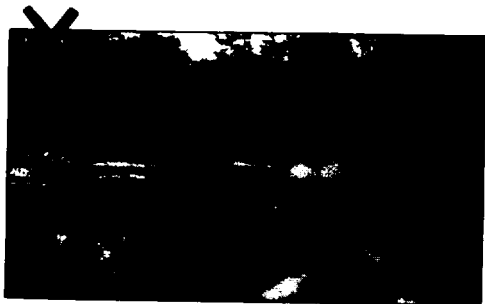

**Warning:** If you take a picture without the autofocus spot  on the main part of your subject as shown above, only the background will be in focus. You can avoid the difficulty by using the focus-lock technique.

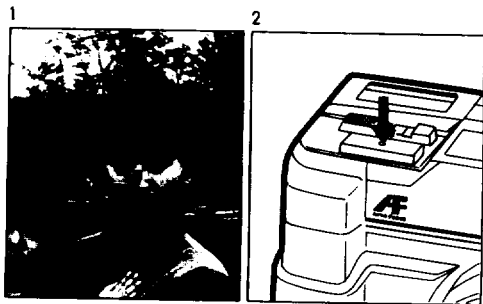

1. When taking a picture of two persons, for example, first bring the autofocus spot  on one of the two.
2. As you depress the shutter button half-way, the green lamp next to the viewfinder eyepiece will light up, and the focus and exposure will be temporarily locked.

● As long as you keep depressing the shutter button half-way with the green lamp lit up, the focus and the exposure memory will stay locked, and they will be cancelled as soon as you release your finger from the shutter button.



3. While keeping the shutter button depressed half-way, reaim the camera to compose your picture as shown above, and finally depress the shutter button completely.

● During the focus-lock operation, you cannot zoom the subject. To do it, you must release your finger from the shutter button.

#### Hard-to-autofocus subjects

The autofocus system of this camera is highly precise, but like many other autofocus cameras, the system is not almighty and may not properly focus on certain subjects. In such a case, use the focus-lock technique on a subject near and equidistant from the actual one. The subjects which are hard to autofocus are:

1. Black objects like hair, etc. which are hard to reflect light (infrared).
2. Wire netting, latticework, iron exercise-bar, etc.
3. Flickering light sources such as neon signs, fluorescent lamps, TV images, sunlight coming through the trees, etc., or any subject illuminated by these light sources.
4. Glass, mirrors, car bodies, etc. which are glossy and reflective.
5. Fast-moving objects like trains.
6. Water jets, surface of water, smoke, flame, fireworks, etc. which are formless.

## EXPOSURE COMPENSATION

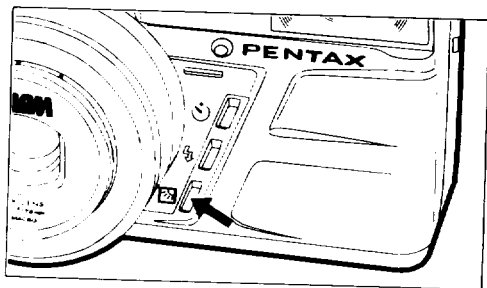

If you take a picture of a person with the sunshine behind, or the bright sky or snow scene in the background, the face tends to be underexposed, looking so dark. To avoid this, release the shutter while keeping the exposure-compensation button  depressed. The face will then be properly exposed and look bright.

When shooting in a poor lighting condition, it is more effective to use flash (as daylight-sync flash as described on page 18) than to use the exposure-compensation technique.



Uncompensated f

Compensated f





## SELF-TIMER

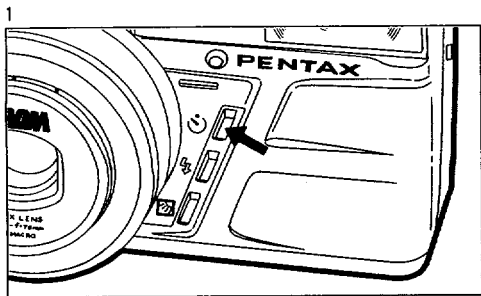

**Use the self-timer when you wish to get yourself into the picture.**

1. Depress the shutter button while keeping the self-timer button  depressed. When the self-timer lamp (red) lights up, you can release your finger from the self-timer button. In about ten seconds, the shutter will be released. A few seconds prior to the shutter release, the lamp starts flickering, indicating the shutter will soon be released.

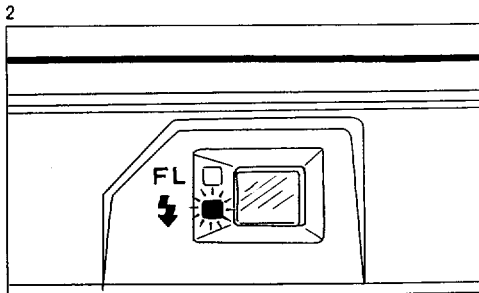

2. In a dark or dimly-lit place, activate the self-timer after making sure the red lamp next to the viewfinder eyepiece (flash-ready indication) lights up. When the red lamp flickers, the safety device keeps the self-timer from working.

- The self-timer operation can be interrupted by either repressing the self-timer button or turning the main switch off.

# ***IQZoom***DATE

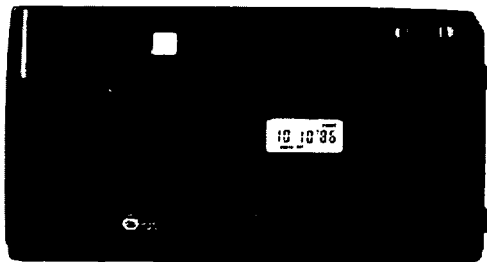

The IQ Zoom DATE is made to record the dates up to the year 2009 on the pictures. The date and time were set when the battery for the dating unit was installed in the factory, so you will have to adjust them in your country.

## OPERATIONAL PRECAUTIONS

### When shooting

- When the data-imprinting section of your picture is very bright without any dark object, the recorded data cannot be seen clearly. Try to see the data section and the white or bright object do not overlap each other.
- The data "Year-Month-Day" and "Hour-Minute" cannot be imprinted at the same time.
- As you release the shutter, the word "PRINT" in the display window flickers for a few seconds, indicating the completion of the data imprinting.

### Battery

One 3-volt lithium battery built in the back cover powers the clock and data display. It should last about five years, although the life may differ, depending on how often it is used or how it is stored. If the clock does not work properly or the LCD displays are not seen clearly, it indicates that the battery is getting weak, so please have it replaced by your nearest, authorized Pentax service facility as soon as possible. Do not try to replace it by yourself. The DATE is designed to work properly in the temperature range of about 50° ~ 0° C.

## SETTING DATA

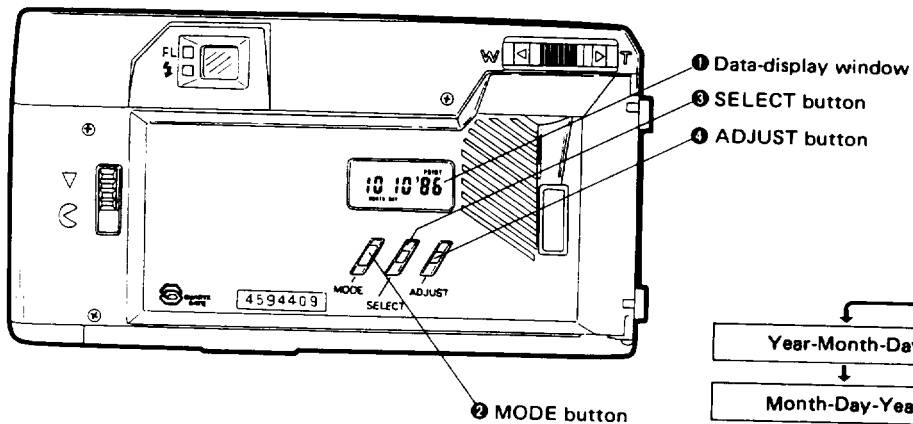

- As long as you keep the ADJUST button depressed in the mode other than Day-Hour-Minute (A/P-Hour: Minute), the data-display window shows the Day-Hour-Minute (A/P-Hour: Minute), serving for a clock.

\*To depress the SELECT or ADJUST button, you can use a match stick or the like.

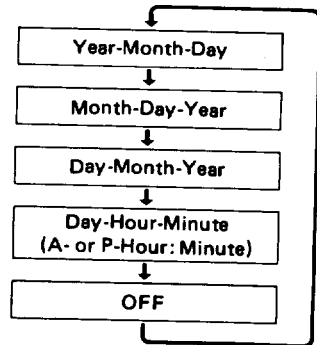

### Switching the mode

Each time you depress the MODE button ② with your fingernail, the mode in the data-display window ① switches from "Year-Month-Day" to "Month-Day-Year" to "Day-Month-Year" to "Day-Hour-Minute" (A- or P-Hour:Minute) to "OFF." Stop depressing the button when the desired mode appears in the window. "OFF" indicates no data are imprinted.

### Correcting the data

- Depress the SELECT button ③ at first, and the display will switch from any mode to "Hour:Minute" with the ":" mark flickering. Each time you depress the SELECT button ③, the flicker moves from ":" to "Minute" to "Hour" to "Day" to "Month" to "Year." Make the display you wish to correct, flicker.
- Depress the ADJUST button ④ for changing the digits of the display you wish to correct. The digit advances one by one each time you depress the ADJUST button ④. If you keep it depressed, the digit will, in a second or two, advance continuously.

### Correcting the second

1. Depress the SELECT button ③, and ":" will flicker.
2. Depress the ADJUST button ④ according to a time-signal, and ":" will stop flickering for an instant, setting the second to zero.

### Correcting "Hour:Minute" and "Year-Month-Day"

1. Make any digit or digits of the hour, minute, year, month, and day (which you wish to correct) flicker by depressing the SELECT button ③.
2. Set the digit or digits correctly by depressing the ADJUST button ④.  
Year = 85 – 09 (1985 – 2009)  
Month = 1 – 12  
Day = 1 – 31  
Hour = 0 – 23 (A or P, 1 – 12)  
Minute = 00 – 59

### Correcting "A," "P," and "Hour:Minute"

1. Set the display to "Day-Hour-Minute" by depressing the MODE button ②.
2. Keep depressing the ADJUST button ④ for a few seconds, and "Day" will switch to "A" (a.m.) or "P" (p.m.).  
Example: 10 15:30 → P 3:30

## STRAP AND SOFT CASE

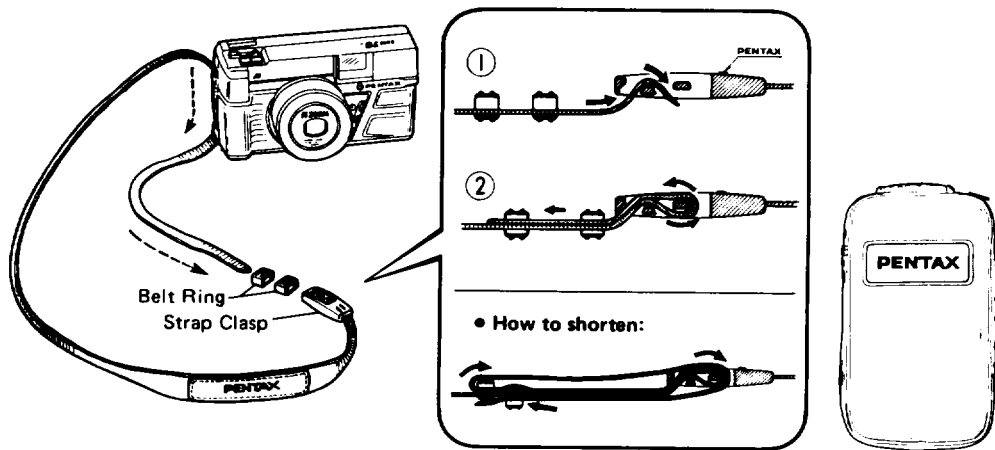

As illustrated, pass the one end of the strap through the camera's strap lug, then through the belt ring through the strap clasp. After fitting the strap on the camera, try pulling it to be sure it does not come off.

### Special soft case

When putting the camera into the soft case, be sure to turn the main switch off.

## BATTERY

- The misuse of battery causes hazards such as leakage, heating, explosions, etc. The battery should be inserted with the (+) or (-) side facing correctly.
- When replacing the AAA-size batteries, do not mix the brand, the type, or old batteries with new ones. Replace four batteries at the same time.
- When not using the camera for a longer period of time, remove the battery from the camera. The old battery is apt to leak, causing damage to the camera. Keep the removed battery beyond the reach of infants.
- Never try to break up or recharge the battery, or throw the used-up one into fire as it may explode.
- The battery may lower its performance in low temperatures, though it differs from one type to another.
- Keep spare batteries on hand for convenience when shooting outdoors or traveling.
- When keeping the camera in a bag, make sure the main switch is off; otherwise, the battery power may be consumed by accidentally pushing the shutter button.

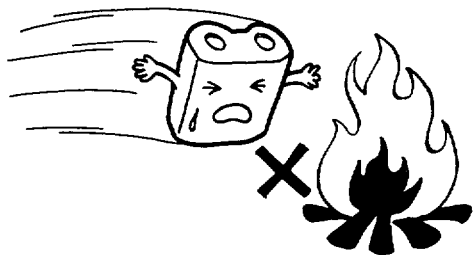

## TAKING CARE OF YOUR CAMERA

Your Pentax camera is a sophisticated, precision instrument built to give long-lasting, reliable service. It will serve you well if you treat it right, with proper handling and reasonable care. The major causes of damage are:

1. Dropping or banging the camera against immovable objects, which can damage the camera in many ways.
2. Water damage, particularly if the camera is submerged in salt water. Your camera is not water-proof! It must be protected from salt breeze, salt spray at the beach, splashing of any kind, and shielded from the rain. If your camera does get soaked, wipe it dry immediately and rush it to a Pentax service center.

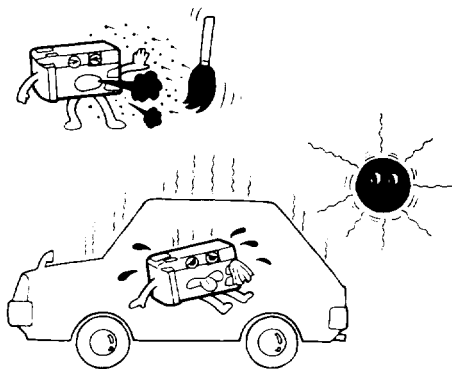
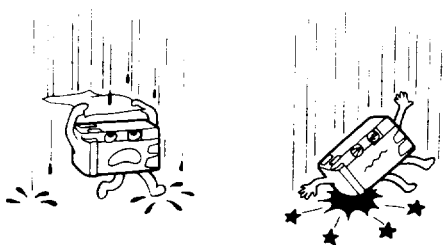

3. Dirt and sand can cause serious damage to the shutter and other moving parts of the camera. Your camera needs periodic cleaning to keep it operating properly. To remove dirt and dust, you need lens-cleaning fluid, lens-cleaning tissues, bulb-type ear syringe, camel's hair brush, etc. Never use a solvent such as thinner or alcohol.
4. Humidity and temperature extremes should be avoided. Keep your camera out of direct sunlight, car trunks, and glove compartments.



Shooting outdoors in winter presents a problem since batteries won't function if they get too cold. In cold weather carry your camera under your coat or jacket to keep the batteries warm. The temperatures at which this camera should function properly are approx.  $50^{\circ} \sim -10^{\circ}\text{C}$ . Sudden changes in temperature will often cause moisture to condense inside or outside your camera. This is a possible source of rust, which may be extremely harmful to the mechanism. Furthermore, if the camera is taken from a warm temperature to a sub-freezing one, further damage may result from the formation of icelets. Thus, sudden temperature changes should be avoided as much as possible. As a guide, a temperature change of  $10^{\circ}\text{C}$  should be allowed to take place gradually over a period of at least 30 minutes. If this is not possible, keeping the camera in its case or bag will help somewhat in minimizing the effects of a rapid temperature change.

5. Vibration experienced when you are traveling in a car, plane, or ship, can cause screws to loosen. To minimize this problem use foam-rubber padding about one inch thick to line the bottom of your camera bag.

6. When mounting your camera on a tripod, make sure the tripod screw is no longer than 5.5mm, which is the depth of your camera's tripod socket. If you use a longer screw, you will possibly puncture the tripod socket, after which the camera will not function properly.
7. Do not place the camera with the zoom lens down without turning the main switch off; otherwise, the zooming mechanism may be seriously damaged.

#### **LCD (Liquid-crystal display)**

- When the LCD is exposed to a high temperature of about  $60^{\circ}\text{C}$ , it may blacken, but when the temperature falls, it will return to normal.
- The LCD may also slow down in response at lower temperatures, but it is one of the LCD's characteristics, not a defect.

#### **LCD-backup power source**

When the battery is removed from the camera for replacement with the film in midroll, the memory circuit for the LCD works for about 20 minutes, but the new battery should be inserted immediately. If the camera is left without the new battery for more than 20 minutes, the exposure counter will be reset and then indicate "1."

## SPECIFICATIONS

**Type:** 35-mm fully-automatic leaf-shutter camera with built-in zoom lens and auto flash. (Auto focusing, auto exposure control, auto film-speed setting, auto-film loading, auto film winding, auto film rewinding, and auto flash control.)

**Film:** 35-mm perforated cartridge DX-coded film with ISO rating from 50 to 1600. 24 x 36 mm format.

**Lens:** Pentax power zoom 35 ~ 70 mm f/3.5 ~ 6.7, 8 elements in 7 groups. 63° ~ 34.5° angle of view.

Autofocus range: one meter to infinity; 0.6 to one meter at MACRO (1/8 magnification).

**Focusing system:** Pentax infrared active auto focusing.

**Exposure control:** Programmed auto-exposure control from EV 9 ~ 15 in WIDE setting, from EV 11 ~ 17 in TELE and MACRO settings at ISO 100 with CdS-cell metering.

**Viewfinder:** Zoom finder with albedo bright frame. Automatic parallax-compensation mechanism by prism at MACRO setting. 82% field of view. Magnification: 0.35X at WIDE setting, 0.64X at TELE setting. -1 diopter.

**Viewfinder information:** Picture-area frame, parallax-correction frame and autofocus spot.

**Shutter:** Programmed-AE, between-the-lens shutter with speeds from approx. 1/250 ~ 1/40 sec. Electro-magnetic shutter release.

**Exposure compensation:** +2EV.

**Meter switch:** Shutter-release button.

**Film loading:** Auto film loading.

**Film winding:** Auto film winding with LCD winding indication.

**Film rewinding:** Auto film rewinding at the end of roll with LCD rewinding indication. Rewind operation stops when rewind is over. Provision for rewinding film in mid-roll.

**Self-timer:** 10-second-delay self-timer with LED indication.

**Flash:** Built-in auto discharge zoom flash.

**Flash recycle time:** Approx. 3 sec. with lithium battery pack or alkaline batteries (at normal temperatures and humidity, and at the earlier stage of use).

**Power source:** One 6V lithium battery pack (DL-223A, CR-P2 or BR-P2) or four "AAA"-size alkaline batte

**Battery life:** Approx. 22 rolls of 24-exposure film with fresh lithium battery pack, or approx. 14 rolls of 24-exposure film with fresh alkaline batteries (at normal temperatures and humidity, and when flash photography and non-flash shooting are made on 50-50 basis).  
**Size & weight:** 138(W) x 74.5(H) x 62.5(D)mm (5.4" x 2.9" x 2.4"); 465 grams (16.3 oz.) without battery.

**DATE model**

**Data imprinting mode:** "Year-Month-Day," "Month-Day-Year," "Day-Month-Year," "Day-Hour-Minute," "A- or P-Hour: Minute" and "OFF" (blank).

**Power source:** Lithium battery (CR-2025) for clock and data display; camera's battery also serves for data imprinting.

**Size & weight:** 138(W) x 74.5(H) x 64.5(D)mm (5.4" x 2.9" x 2.5"); 480 grams (16.8 oz.) without battery.

**Accessories for both modes:** Strap (standard) and soft case (optional).

## WARRANTY POLICY

All Pentax cameras purchased through authorized bona fide photographic distribution channels are guaranteed against defects of material or workmanship for a period of twelve months from date of purchase. Service will be rendered and defective parts will be replaced without cost to you within that period, provided the equipment does not show evidence of impact, sand or liquid damage, mishandling, tampering, battery or chemical corrosion, operation contrary to operating instructions, or modification by an unauthorized repair shop. The manufacturer or its authorized representatives shall not be liable for any repair or alterations except those made with its written consent and shall not be liable for damages from delay or loss of use or from other indirect or consequential damages of any kind, whether caused by defective material or workmanship or otherwise; and it is expressly agreed that the liability of the manufacturer or its representatives under all guarantees or warranties, whether express or implied, is strictly limited to the replacement of parts as hereinbefore provided. No refunds will be made on repairs performed by non-authorized Pentax service facilities.

### **Procedure During 12-month Warranty Period**

Any Pentax which proves defective during the 12-month warranty period should be returned to the dealer from whom you purchased the equipment or to the manufacturer. If there is no representative of the manufacturer in your country, send the equipment to the manufacturer, with postage prepaid. In this case, it will take a considerable length of time before the equipment can be returned to you owing to the complicated customs procedures required in Japan in importing and re-exporting photographic equipment. If the equipment is covered by warranty, repairs will be made and parts replaced free of charge, and the equipment will be returned to you upon completion of servicing. If the equipment is not covered by warranty, regular charges of the manufacturer or of its representatives will apply. Shipping charges are to be borne by the owner. If your Pentax was purchased outside of the country where you wish to have serviced during the warranty period, regular handling and servicing fees may be charged by the manufacturer's representatives in that country. Notwithstanding this, your Pentax returned to the manufacturer will be serviced free of charge according to this procedure and warranty policy. In any case,

however, shipping charges and customs clearance fees are to be borne by the sender. To prove the date of your purchase when required, please keep the receipts or bills covering the purchase of your equipment for at least a year. Before sending your equipment for servicing, please make sure that you are sending it to the manufacturer's authorized representatives or their accredited repair shops, unless you are sending it directly to the manufacturer. Always obtain a quotation of the service charge, and only after you accept the quoted service charge, instruct the service station to proceed with the servicing.

This warranty policy does not apply to Pentax products purchased in the U.S.A., U.K., or Canada. The local warranty policies available from Pentax distributors in those countries supersede this warranty policy.

## NAMES OF WORKING PARTS

Zooming lever

Film-information window

Viewfinder eyepiece

Green lamp

Red lamp

Back-cover-release lever

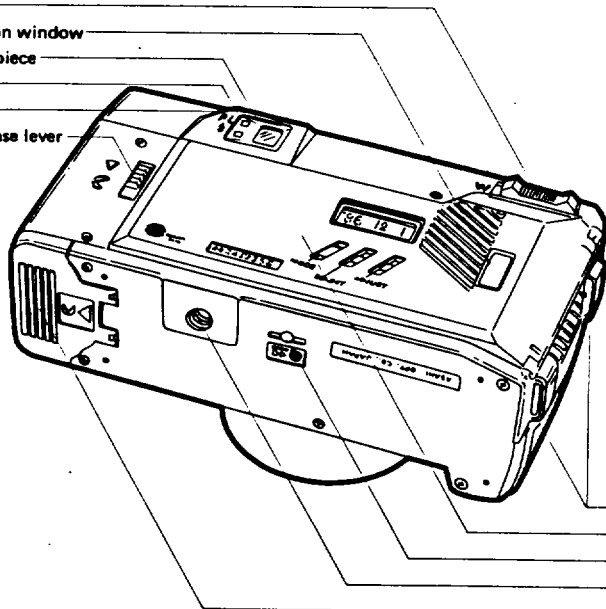

Strap lug

Back cover

Auxiliary rewind button

Tripod socket

Battery-chamber cover

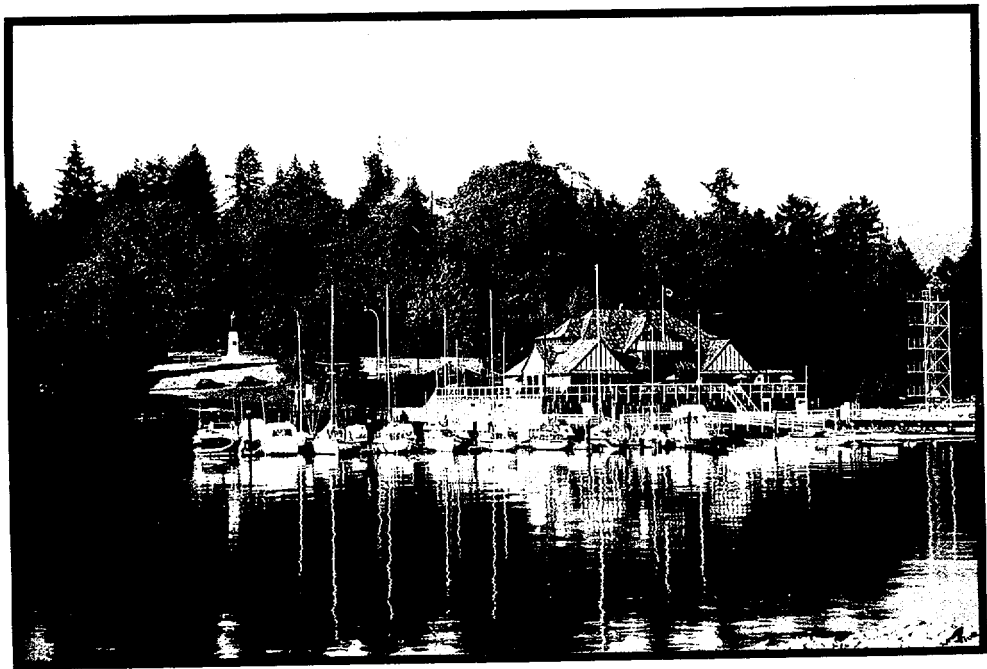



Asahi Optical Co., Ltd. C.P.O. 865, Tokyo 100-91, JAPAN

Pentax Europe n.v. Welvedaan 3-5, 1830 Zaventem Zuid-7, BELGIUM

Pentax Handelsgesellschaft mbH Postfach 54 0169, 2000 Hamburg 54, WEST GERMANY

Pentax U.K. Limited Pentax House, South Hill Avenue, South Harrow, Middlesex HA2 0LT, U.K.

Pentax France S.A. Z.I. Argenteuil, 12, Rue Ambroise-Crotzat, 95100 Argenteuil, FRANCE

Pentax (Schweiz) AG Industriestrasse 2, 8305 Dietlikon ZH, SWITZERLAND

Pentax Scandinavia AB Box 850, S-751 27 Uppsala, SWEDEN

Pentax Nederland Spinveld 25, 4815 HR Breda, THE NETHERLANDS

Pentax Norge A.S. Cecilie Thorsens VEI, Lambertseter, 1101 Oslo 11, NORWAY

Pentax Corporation 35 Inverness Drive East, Englewood, Colorado 80112, U.S.A.

Pentax Canada Inc. 3131 Universal Drive, Mississauga, Ontario L4X 2E5, CANADA

Asahi Optical Brasileira Ind. e Com. Ltda. Rua Capitão Antonio Ross 378, Sala 121 Ed. PBK, São Paulo, BRASIL

Specifications are subject to change without notice.

58940 ENG

Copyright © Asahi Optical Co., Ltd. 1986

1/88 Printed in Japan