

PENTAX®

SPORT / SPORT

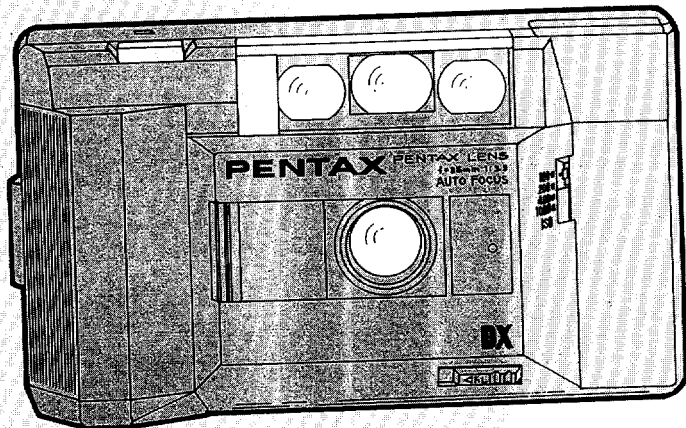

Thank you very much for choosing the Pentax SPORT or SPORT DATE.

As you may already know, this new addition to the Pentax line-up of 35mm compact cameras offers you the convenience of so many "auto's" such as auto exposure, auto focusing, auto film loading, auto film winding/rewinding, auto film-speed setting and auto flash. Moreover, the SPORT DATE is equipped with an automatic data-recording unit to imprint the date and time on your photographs, as well as all the features already available in the SPORT.

Please read this operating manual through very carefully so that you can fully enjoy this sophisticated precision instrument built to give long-lasting, reliable service for many years to come.

TABLE OF CONTENTS

SHORT OPERATING COURSE; PRECAUTIONS	1
NAMES OF WORKING PARTS	2
LOADING BATTERIES	4
OPENING/CLOSING LENS COVER	6
BATTERY CHECK	7
SETTING ISO FILM SPEED	8
LOADING FILM	10
CAMERA HOLDING	13
TAKING PICTURES	14
RECOMMENDED CAMERA-TO-SUBJECT DISTANCE	16
REWINDING FILM	17
FOCUS-LOCK TECHNIQUE	18
USING FLASH	20
SPORT DATE	22
SETTING DATE	24
ATTACHING STRAP; SOFT CASE	26
TAKING CARE OF YOUR CAMERA	28
SPECIFICATIONS	30
WARRANTY POLICY	32

Operating Order

- (1) Load the batteries.
- (2) Open the lens cover.
- (3) Check the batteries.
- (4) Set the film speed.
- (5) Load the film.
- (6) Take a picture.
- (7) When the film comes to an end, rewind and unload it.

Precautions

The shutter cannot be released in the following cases:

1. When the batteries are not loaded in the camera; when they are exhausted or not loaded properly.
2. When the lens cover is closed or partially open.
3. When auto winding or rewinding is taking place, or when the film comes to an end or rewind is over.
4. When the back cover is open.
5. When the recycling time of the flash becomes extremely slower.

Because the battery discharges small amounts of energy even when not in use, those supplied with your camera may be slightly below full capacity.

NAME OF WORKING PARTS

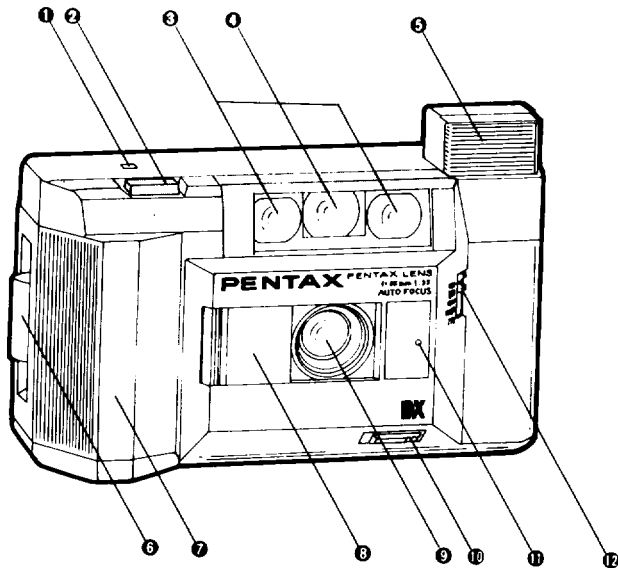

- ❶ Frame Counter
- ❷ Shutter Release Button
- ❸ Auto Focus Windows
- ❹ Viewfinder Window
- ❺ Flash Head
- ❻ Strap Tube
- ❼ Grip
- ❽ Lens Cover
- ❾ Taking Lens
- ❿ Focus-lock Lever
- ⓫ Light Sensor Window
- ⓬ Manual Film Speed Selector

- ⑬ Back Cover Release Lever
- ⑭ Film Leader End Mark
- ⑮ Flash Ready Indicator
- ⑯ Viewfinder Eyepiece
- ⑰ Thumb Grip
- ⑱ Film-loaded Indicator
- ⑲ Flash Pop-up Lever
- ⑳ Film Rewind Lever
- ㉑ Film Transport Indicator
- ㉒ Tripod Socket
- ㉓ Battery Chamber Cover

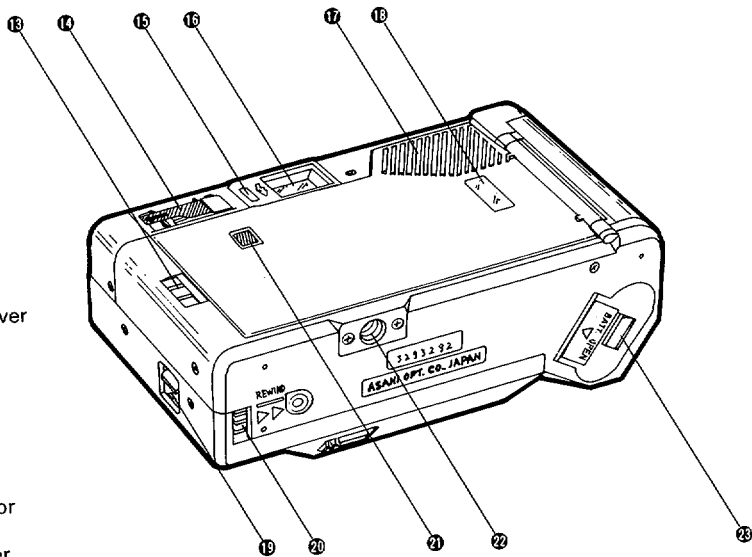

LOADING BATTERIES

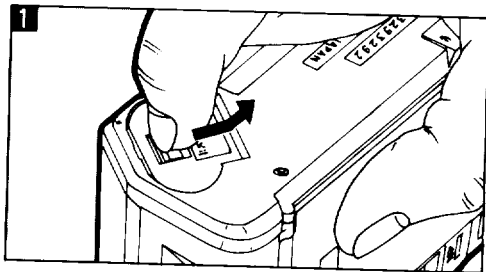

1. Open the Battery Chamber Cover at the base of the camera by sliding it in the direction of the arrow; use a fingernail in the groove to push and raise the cover.

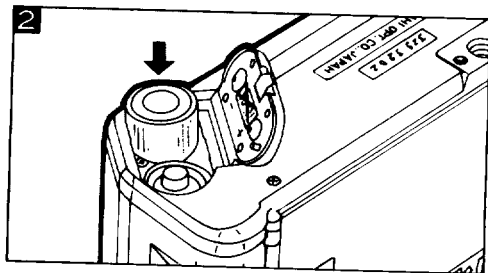

2. Fit two batteries into the chamber as indicated with the + and - markings.

This camera does not operate without batteries in it. Use two 1.5V AA penlight Alkaline batteries. DO NOT use Ni-Cd or Manganese batteries.

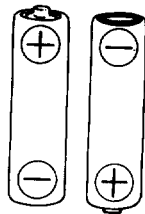

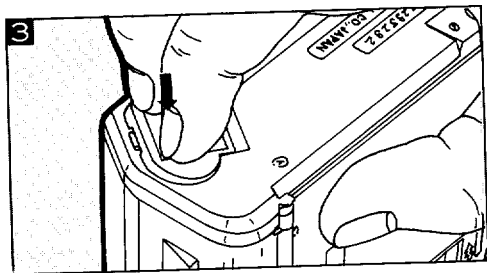

3. Close the cover by pushing it back.



Batteries

- The batteries should be inserted correctly according to the + and - markings indicated in the chamber.
- When replacing, be sure to use two fresh batteries of the same brand and type.
- If the batteries are not used for a long time, remove them from the camera. Leaving them in the camera may cause acid leakage and possible damage to the camera mechanism.
- Never break up, recharge or throw used batteries into fire as they may explode.

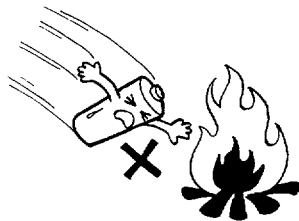

OPENING/CLOSING LENS COVER

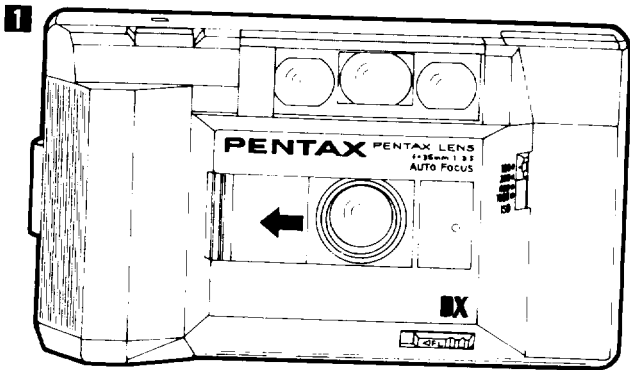

1. Open the Lens Cover by sliding it in the direction of the arrow, until it stops. To close, just push the Lens Cover back, locking it in its original position.

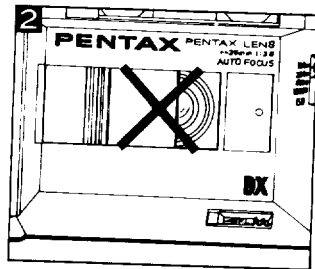

2. When the Lens Cover is slightly pushed back or completely closed, a safety device locks the Shutter Release Lever to prevent accidental shutter release.

BATTERY CHECK

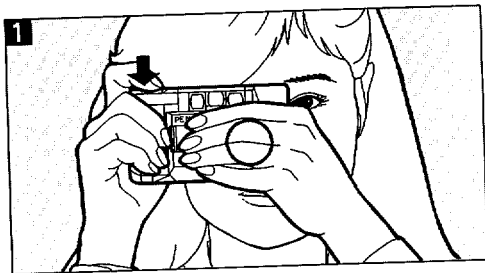

1. After opening the Lens Cover, softly depress the Shutter Release Button while covering the Light Sensor Window with your hand, as illustrated. Do not mark the Window with your fingerprints.
2. When the red lamp lights up in the top center of the viewfinder, the batteries are properly loaded in the camera. If they are incorrectly loaded, or weak or dead, the Shutter Release Button cannot be depressed,

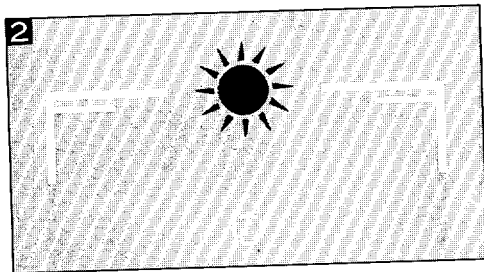

nor can film be wound. If the batteries are getting weak, replace both batteries with fresh ones.

Battery Power Check

If the batteries are getting weak, the flash recycle time and the auto winding/rewinding time will become much slower.

SETTING ISO FILM SPEED

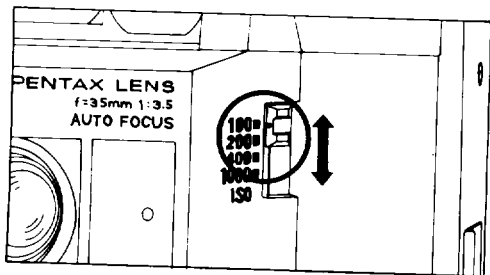

Non-DX film

Align the white dot of the Manual Film Speed Selector with the corresponding ISO number of the film being used. When using the DX film as described on the next page, you do not have to move this Selector at all.

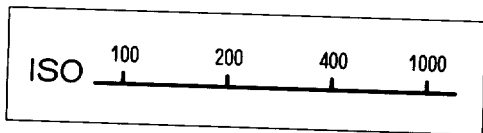

Do not set the Selector in between the numerals.

The film speeds usable with this camera are ISO 100, 200, 400 and 1000.

- The film speed is indicated on the film package.

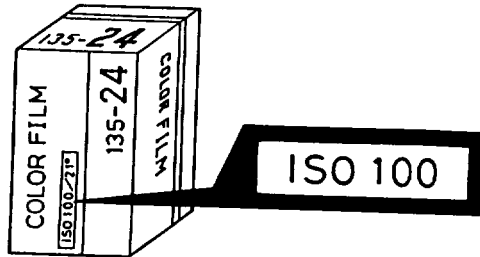

DX FILM

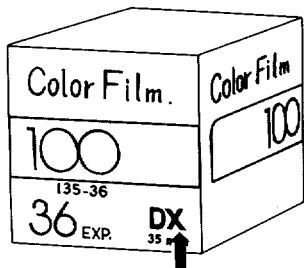

When the camera is loaded with the DX film, its film speed is automatically set by the camera no matter where the Manual Film Speed Selector is set.
The automatic film speed setting of DX film ranges from ISO 100 to 1000.

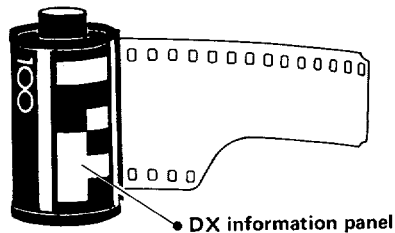

When using the DX film, make sure that the package bears the DX mark (which differs from one brand to another) or the cassette has the DX information panel, since there is also the non-DX film of the same type.

LOADING FILM

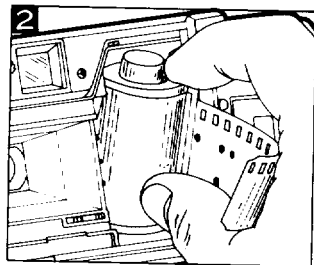
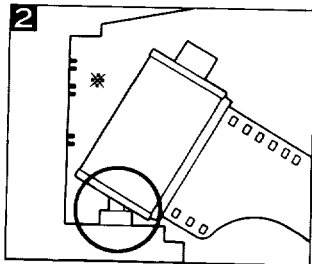
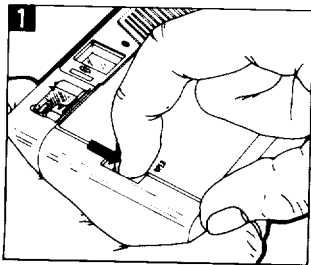

Always load or unload film in a shady spot, or shield the camera and film from direct sunlight with your body.

1. Open the back cover by sliding the back cover release lever in the direction of the arrow.

2. As illustrated, place the film cartridge in the film chamber by first fitting its flat side on the top of the rewind shaft.

**** Always keep the DX-information pins free from scratches, dirt or dust.***

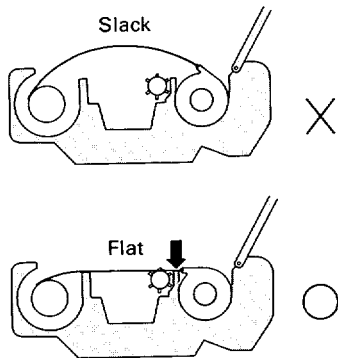
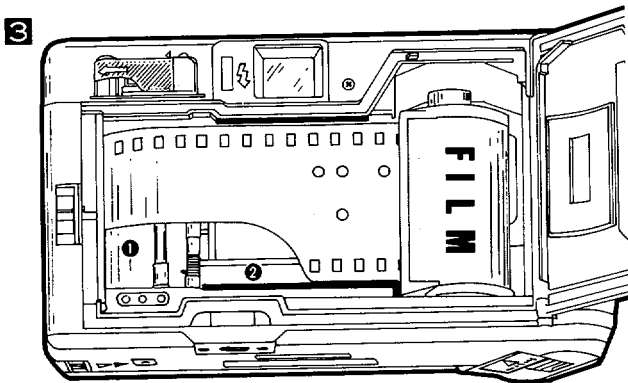

3. Pull the film leader out far enough to be placed on the ❶ film roller/take up spool, as shown above.

- Make sure the film is properly placed between the ❷ guide rails.
- Take up any slack left in the film so that it is flat, as illustrated above.

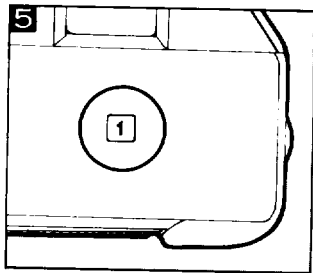
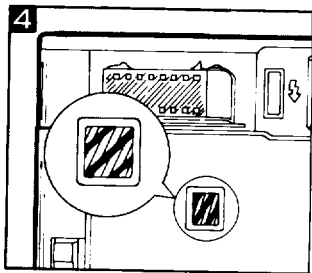
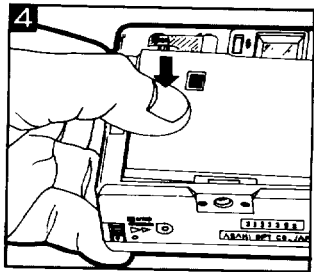

4. Close the back cover, and the film will be automatically wound on to the first frame.

- When the film is being wound on, the red stripes in the film transport indicator flicker, indicating that the film is advancing properly, if not, open the back cover and reload the film.

5. When the frame counter is set to "1," the auto film winding stops automatically. Now you are ready to start shooting.

- The film-loaded indicator on the back cover tells you whether or not film is in the camera.

CAMERA HOLDING

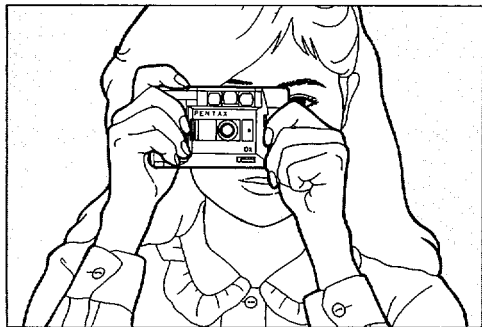

It is important to hold the camera properly in order to take blur-free photos. Practice holding and operating the camera before inserting your first roll of film.

The illustrations show the basic holding positions. No matter which position you use, be sure to grip the camera steadily with both hands, hold the camera gently against the face

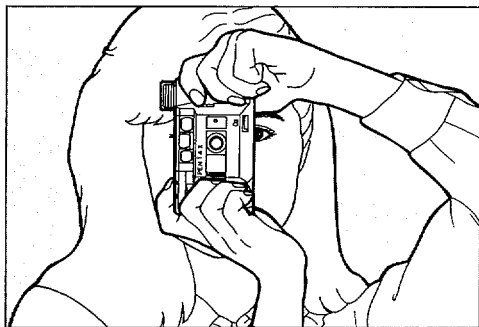

in a fixed position, and relax the rest of your body in a secure posture. Brace the elbow of the arm supporting the camera against your body. Always press the Shutter Release Button gently.

When taking flash pictures with the camera held vertically, be sure to keep the flash head on the upper side.

TAKING PICTURES

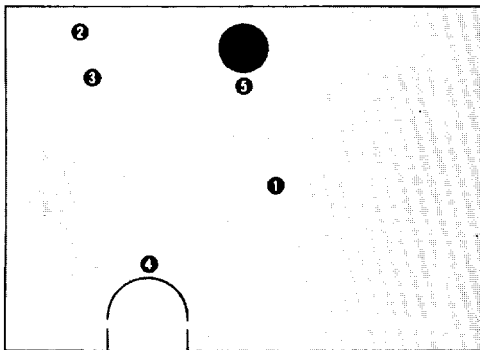

- 1 Auto Focus Spot (Bring this on to what you want to focus on.)
- 2 Picture Area Frame (General-photography range)
- 3 Parallax Correction Frame (Short-distance-photography range)
- 4 Focus-lock Indicator (Appears when camera-to-subject distance is locked.)
- 5 Red Lamp (Camera-shake warning LED)

14



1. After composing your picture, bring the 1 Auto Focus Spot on to the main subject you want to focus on.
 - In this instance, be sure to keep your hands, hair, etc. away from the Auto Focus Windows, Taking lens, Light Sensor Window or Flash Head.
2. Softly depress the Shutter Release Button. If the 5 Red Lamp does not light up in the top center of the viewfinder, it indicates the

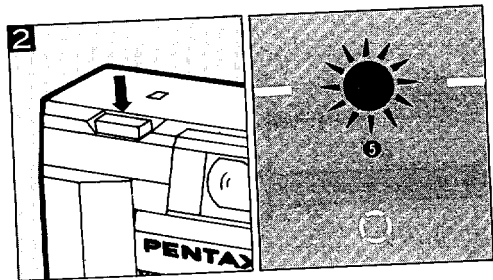

shutter speed is fast enough for handheld shooting; in other words, the subject is bright enough to shoot without flash.

- When the camera-to-subject distance is around one meter (3.3 ft.), compose your picture within the ③ Parallax Correction Frame.
- When the ⑤ Red Lamp lights up, it indicates that the subject is so dark, you have to use flash. Refer to USING FLASH pages.

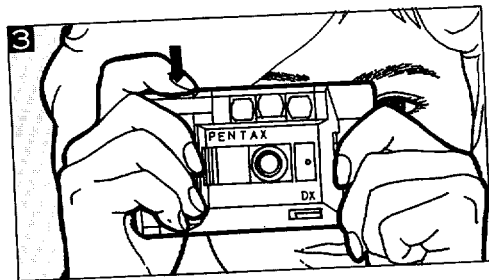

3. Further depress the Shutter Release Button to release the shutter. As you release your finger from the Button, the film will be automatically wound on to the next frame.
- When the shutter is released, the ④ Focus-lock Indicator will appear on the lower left of the viewfinder with a hissing sound, indicating that a picture has been taken.

RECOMMENDED CAMERA-TO-SUBJECT DISTANCE

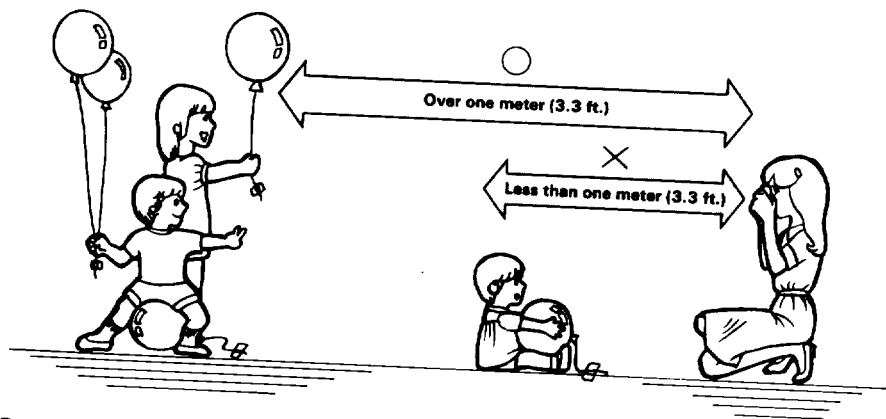

- For the best possible results, take your pictures within the camera-to-subject distance from one meter to ∞ (infinity). This camera does not focus on the subject less than one meter (3.3 ft.) away.

REWINDING FILM

When the last frame of the roll is exposed, the motor will automatically stop. Do not open the back cover, but rewind the film and take the cartridge out of the camera in the following ways:

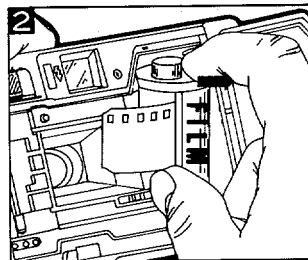
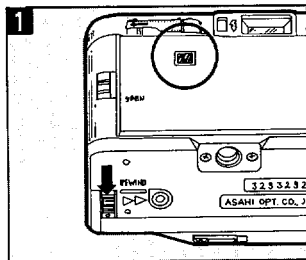

1. To rewind the film, slide the Film Rewind Lever in the direction of the arrow. The motor will automatically start to rewind the film. The red stripes in the Film Transport Indicator keep flickering while the film is being rewound. Do not open the back cover until the motor stops flickering.

- It takes about 40 seconds for the 36-exposure film to be rewound into the cartridge.

2. Open the back cover, and remove the cartridge from the chamber by using a finger on the top of the cartridge.

- When the battery power gets extremely low, the motor may stop in the middle of rewinding. Should it happen, replace the batteries with new ones to complete the rewinding.

FOCUS-LOCK TECHNIQUE



If the subject you wish to focus on is out of the Auto Focus Spot as shown above, it will be out of focus and only the background will be in focus. You can avoid this problem by using the focus-lock technique in the following order.

- In dimly-lit places, make sure in advance whether the red lamp lights up or not, to see if flash is needed or not.

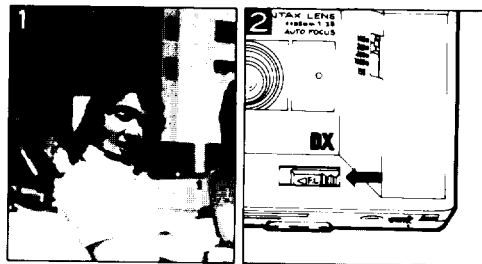

1. Bring the Auto Focus Spot on the main subject.

2. As illustrated, slide the Focus-lock Lever in the direction of the arrow, and the Focus-lock Indicator will appear at the lower left hand side of the viewfinder. Now, the lens has been focused on the subject temporarily.



3. Move the camera to recompose your picture with the subject in the desired position, then depress the Shutter Release Button all the way to take the picture.

- Once you have locked the focus, you cannot release the focus lock until you have finished taking a picture of the focused subject.

Difficult Auto-focus Subjects

The auto focus system of this camera may not function properly in the situations described below. In such cases, focus on a subject near the actual subject you are shooting, and lock the focus by using the focus-lock technique, then frame the subject and shoot.

1. Black objects which are hard to reflect light (infrared).
2. Wire netting, latticework, iron exercise-bar, etc. with less light reflection.
3. When neon signs, fluorescent lamp, television, sunlight coming through the trees, etc. are in or around the Auto Focus Spot.
4. Glass panelling, mirrors, car bodies, etc. which are glossy and reflective.
5. Fast-moving objects such as trains and cars.
6. Water jets, water surfaces, smoke, flame, fireworks and other transparent or translucent objects.

USING FLASH

If the red lamp lights up in the top center of the viewfinder when the Shutter Release Button is depressed half-way, it is a warning that you should use flash to avoid an underexposed picture or a blurred picture caused by a slower shutter speed.

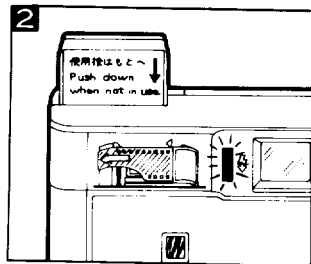
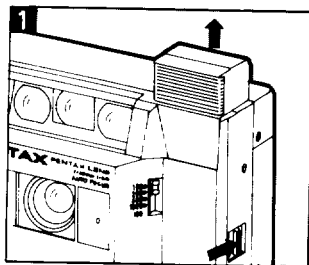

Using flash as a supplementary light source in daylight

If you are shooting people in the shade of trees or in a dimly-lit place, you can also use flash to prevent their faces from being underexposed.

1. Slide the Flash Pop-up Lever in the direction of the arrow, and the Flash Head will pop up and begin to charge automatically.

2. Several seconds later, the Flash Ready Indicator by the Viewfinder Eyepiece will light up, indicating that the flash is ready to fire. Be sure to depress the Shutter Release Button after ensuring that the indicator light is on. Push the Flash Head back into place to return the camera to normal picture-taking mode.

- It takes about five seconds for the flash to be fully charged with fresh batteries, and it takes longer as they get weak. If more than 15 seconds, the shutter may not be released, thus making it necessary to replace the batteries.

Number of film rolls for flash photography

Approx. ten rolls of 24-exposure film or seven rolls of 36-exposure film can be used for flash photography with fresh batteries at normal temperatures and humidity.

Flash control range

1 ~ 2.8 m (3.3 ~ 9.2 ft.) with ISO 100 film

1 ~ 4.2 m (3.3 ~ 13.8 ft.) with ISO 200 ~ 1000 film

- When the Flash Head is in the up position, the red lamp does not light up even if the Shutter Release Lever is depressed slightly.
- Releasing the shutter before the Flash Ready Indicator lights up will result in underexposure.
- Take care not to depress the Shutter Release Lever even softly before the Flash Ready Indicator lights up. Otherwise, the charging will be interrupted.
- Always keep the Flash Head back in the camera when not in use; otherwise, the batteries can be easily exhausted.

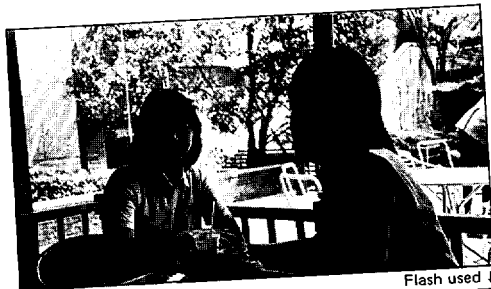

Flash not used ↑



Flash used ↓

SPORT DATE

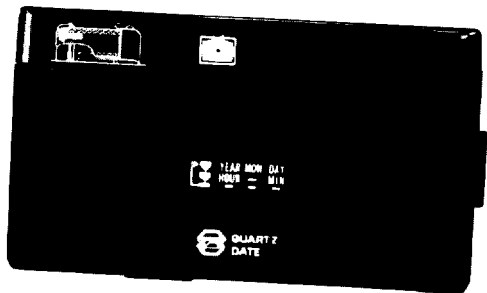

PRECAUTIONS

Usable films

- Any non-DX film with ISO 100, 200, 400 or 1000.
- Any DX film with ISO 100 ~ 1000. The film speed is automatically set.

When shooting

- If the data printing section in the picture area is too bright, the recorded data may be difficult to see. Frame the picture so that reflections or white objects may not overlap the data printing section.
- The Year/Month/Day and Hour/Minute data cannot be imprinted on the same picture.
- When the shutter is released, the letters "PRINT" will appear in the Display Window, indicating that imprinting has been completed.

Battery

The data-recording unit is powered by a 3-V lithium battery (CR-2025) which is built in the back cover. It should last about five years, although the life may differ, depending on how often it is used or how it is stored. If the unit does not work properly or the LCD displays are not seen clearly, it indicates that the battery is getting weak, so please have it replaced by your nearest, authorized Pentax service facility as soon as possible. Do not try to replace it by yourself.

LCD (Liquid Crystal Display)

- When the LCD is exposed to a high temperature of around 60°C, it may blacken, but when the temperature falls, it will return to normal.
- The LCD may also tend to slow down in response at lower temperatures, but it is one of the characteristics of LCD's, not a defect.
- The unit should work perfectly in the temperature range of around 50° ~ 0°C.

SETTING DATA

① Display Window

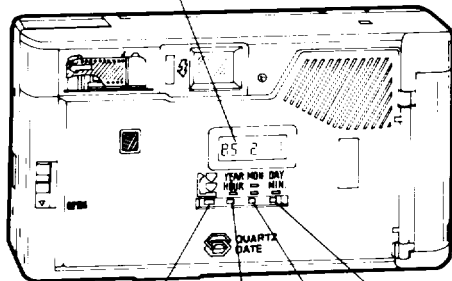

② Mode Selector Button

Setting Button

③	④	⑤
YEAR	MON. (Month)	DAY
HOUR	—	MIN (Minute)
— —	—	— —

Setting Data

- The mode display in the ① Display Window will switch from "Year-Month-Day" to "Hour-Minute" to "- - - - -" (No Display) in this order each time the ② Mode Selector Button is depressed. Stop depressing the ② Button when the desired mode is displayed.
- Depressing the Setting Button ③, ④ or ⑤ once will advance the displayed figures one at a time. For rapid advance, keep depressing the button, and within a second or two, the figure will increase continuously. To depress the button, use a ball-point pen or the like.
- Unless the "Hour-Minute" mode is correctly set, the "Year-Month-Day" mode will not be correctly set.

Setting "Hour-Minute" Mode

15 - 30 (= 3:30 p.m.)

1. Press the Mode Selector Button until the "Hour-Minute" mode is set in the Display Window.
2. Press the ④ Setting Button and set the second according to the announcement of time or your watch. The second "—" will be set to zero, although it will just keep flickering in the Display Window.
3. Press the ⑤ Setting Button and set the minute to "30" in the Display Window.
4. Press the ③ Setting Button and set the hour to "15" in the Display Window. The 24-hour clock designation is used for the time indication.
 - Note that the second "—" flickers every second, and if you release the shutter while it is appearing, it will be imprinted on the film.

Setting "Year-Month-Day" Mode

85 2 1 (= February 1, 1985)

1. Press the Mode Selector Button until the "Year-Month-Day" mode is set in the Display Window.
2. Press the ⑥ Setting Button and set the year to "85" in the Display Window.
3. Press the ④ Setting Button and set the month to "2" in the Display Window.
4. Press the ⑤ Setting Button and set the day to "1" in the Display Window.

ATTACHING STRAP; SOFT CASE

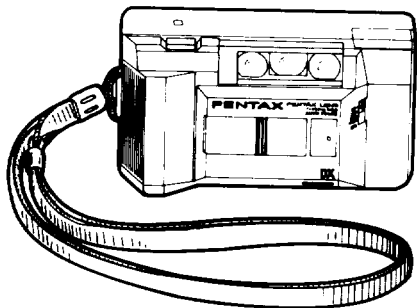

You can use this strap as a neck strap or a wrist strap.

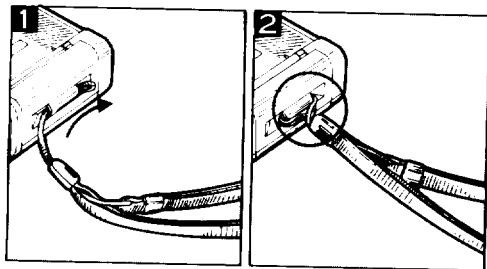

1. Pass the string of the strap through the Strap Tube.
2. Pass the other end of the strap through the ring of the string. You have now a wrist strap.

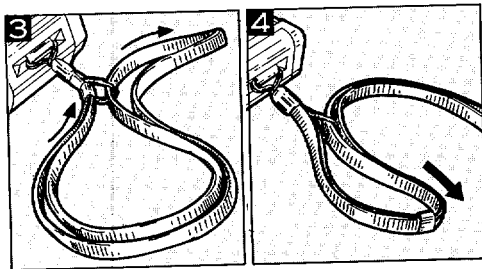

3. To make it a neck strap, move the belt ring to the other end of the strap, and then, as illustrated, pull the strap out from the small ring.

4. To return it to a wrist strap, pull the belt ring out from the small ring, and move the belt ring to the other end of the strap.



This soft case is optional. Pass the strap attached to the camera, through the hole on the top of the case.

TAKING CARE OF YOUR CAMERA

Your Pentax camera is a sophisticated, precision instrument built to give long-lasting, reliable service. It will serve you well if you treat it right, with proper handling and reasonable care. The major causes of damage are:

1. Dropping or banging the camera against immovable objects, which can damage the camera in many ways.
2. Water damage, particularly if the camera is submerged in salt water. Cameras are not water-proof! They must be protected from salt spray at the beach, splashing of any kind, and shielded from the rain. If your camera does get soaked, wipe it dry immediately and rush it to a Pentax service center.
3. Dirt and sand can cause serious damage to the shutter and other moving parts of the camera. Your camera needs periodic cleaning to keep it operating properly. To remove dirt and dust, you need lens-cleaning fluid, lens-cleaning tissues, bulb-type ear syringe, camel's hair brush, etc. Never use a solvent such as thinner or alcohol.

4. One set of batteries should last a year with average use without using flash, at normal temperatures. Humidity and temperature extremes should be avoided. Keep your camera out of direct sunlight, car trunks, and glove compartments. Shooting outdoors in winter presents a problem since batteries won't function if they get too cold. In cold weather carry your camera under your coat or jacket to keep the batteries warm. The temperatures at which this camera should function properly are approx. $50^{\circ} \sim -10^{\circ}\text{C}$.
5. Vibration experienced when you are traveling in a car, plane, or ship, can cause screws to loosen. To minimize this problem use foam-rubber padding about one inch thick to line the bottom of your camera bag.



SPECIFICATIONS

Type: Fully automatic leaf-shutter camera with built-in pop-up flash, auto film speed setting, auto focusing, auto exposure control, auto film winding, and auto rewinding.

Film: 35mm perforated cartridge film. 24 x 36mm format.

Lens: Pentax 35mm f/3.5, 4 elements in 4 groups.

Focusing: Pentax infrared active triangular measuring system (1m to infinity) with focus lock device.

Exposure Control: Programmed automatic exposure control from EV8 to EV15 at ISO 100 with CdS cell metering. Slow shutter warning by LED display.

Viewfinder: Albada bright-frame viewfinder. Picture area: 85%. Magnification: 0.44X. Diopter: -0.86 diopter.

Viewfinder Information: Picture area frame, parallax correction frame, auto focus spot.

Shutter: Electronically programmed behind-the-lens shutter, shutter speed from approx. 1/20 to 1/400 sec. Electro-magnetic release.

Film Winding: Automatic winding system with film advance indicator. Winding speed 1 sec. per frame.

Film Loading: Automatic film loading

Film Rewinding: Semi-automatic rewind mechanism. Rewind Speed: 40 sec. for 36-exposure film.

Film Speed Setting:

1) DX film auto setting — ISO 100 to ISO 1000.

2) Manual setting — ISO 100, 200, 400, 1000.

Flash: Built-in pop-up type with flash ready light. Guide number 10 (ISO 100/m).

Flash Recycling Time: Approx. 5 seconds with fresh alkaline batteries.

Number of Flashes: About 10 rolls of 24-exposure film or about 7 rolls of 36 exposure film at 30-second intervals and at normal temperatures.

Power Source: Two "AA" alkaline batteries.

Size & Weight: 120mm x 68.5mm x 46mm (4.7" x 2.7" x 1.8"); 285 g (10.1 oz.) without batteries.

SPORT Date

Data Recording System: An internal recording lamp records information onto reverse side of film.

Data Imprinting Mode: Push buttons to set unit to any of three modes; "Year/Mon/Day", "Hour/Min", or "- - - -" (blank). Year/Mon/Day mode ("80" to "19" — 1980 to 2019); Month ("1" to "12"); Day ("1" to "31"). Hour/Min mode: Hour ("0" to "23"); Minute ("00" to "59").

Blank Mode: "- - - -" (no data imprinted).

Power Source: One 3V lithium battery.

Size & Weight: 120mm x 68.5mm x 46mm (4.7" x 2.7" x 1.8"); 295 g (10.4 oz.) without batteries.

WARRANTY POLICY

All Pentax cameras purchased through authorized bona fide photographic distribution channels are guaranteed against defects of material or workmanship for a period of twelve months from date of purchase. Service will be rendered and defective parts will be replaced without cost to you within that period, provided the equipment has not been abused, altered, or operated contrary to instruction. Because the tolerances, quality, and design compatibility of lenses other than Pentax lenses are beyond our control, damage caused by use of such lenses will not be covered by this warranty policy. The manufacturer or its authorized representatives shall not be liable for any repair or alterations except those made with its written consent and shall not be liable for damages from delay or loss of use or from other indirect or consequential damages of any kind, whether caused by defective material or workmanship or otherwise; and it is expressly agreed that the liability of the manufacturer or its representatives under all guarantees or warranties, whether expressed or implied, is strictly limited

to the replacement of parts as hereinbefore provided.

Procedure During 12-month Warranty Period

Any Pentax which proves defective during the 12-month warranty period should be returned to the dealer from whom you purchased the equipment or to the manufacturer. If there is no representative of the manufacturer in your country, send the equipment to the manufacturer, with postage prepaid. In this case, it will take a considerable length of time before the equipment can be returned to you owing to the complicated customs procedures required in Japan in importing and re-exporting photographic equipment. If the equipment is covered by warranty, repairs will be made and parts replaced free of charge, and the equipment will be returned to you upon completion of servicing. If the equipment is not covered by warranty, regular charges of the manufacturer or of its representatives will apply. Shipping charges are to be borne by the owner. If your Pentax was

purchased outside of the country where you wish to have serviced during the warranty period, regular handling and servicing fees may be charged by the manufacturer's representatives in that country. Notwithstanding this, your Pentax returned to the manufacturer will be serviced free of charge according to this procedure and warranty policy. In any case, however, shipping charges and customs clearance fees are to be borne by the sender. To prove the date of your purchase when required, please keep the receipts or bills covering the purchase of your equipment for at least a year. Before sending your equipment for servicing, please make sure that you are sending it to the manufacturer's authorized representatives or their accredited repair shops, unless you are sending it directly to the manufacturer. Always obtain a quotation of the service charge, and only after you accept the quoted service charge, instruct the service station to proceed with the servicing.

This warranty policy does not apply to Pentax products purchased in the U.S.A., U.K., or Canada. The local warranty policies available from Pentax distributors in those countries supersede this warranty policy.



Asahi Optical Co., Ltd. C.P.O. 895, Tokyo 100-91, JAPAN
Pentax Europe n.v. Weveldlaan 3-5, 1930 Zaventem Zuid-7, BELGIUM
Pentax Handelsgesellschaft mbH Postfach 54 0169, 2000 Hamburg 54, WEST GERMANY
Pentax U.K. Limited Pentax House, South Hill Avenue, South Harrow, Middlesex HA2 0LT, U.K.
Pentax France S.A. Z.I. Argenteuil, 12, Rue Ambroise-Croizat, 95100 Argenteuil, FRANCE
Pentax (Schweiz) AG Industriestrasse 2, 8305 Dietlikon ZH, SWITZERLAND
Pentax Svenska AB Box 650, S-751 27 Uppsala, SWEDEN
Pentax Nederland Spinveld 25, 4815 HR Breda, THE NETHERLANDS
Pentax Norge A/S Stenersgt. 18, Oslo 1, NORWAY
Pentax Corporation 35 Inverness Drive East, Englewood, Colorado 80112, U.S.A.
Pentax Canada Inc. 1760 West 3rd Avenue, Vancouver, B.C. V6J 1K5, CANADA
Asahi Optical Brasileira Ind. e Com. Ltda. Rue Capitão Antonio Rosa 376, Sala 121 Ed. PBK, São Paulo, BRASIL

Specifications are subject to change without notice.
08081 ENG

Copyright © Asahi Optical Co., Ltd. 1984
6/85 Printed in Japan