

HONEYWELL
PENTAX

SP1000

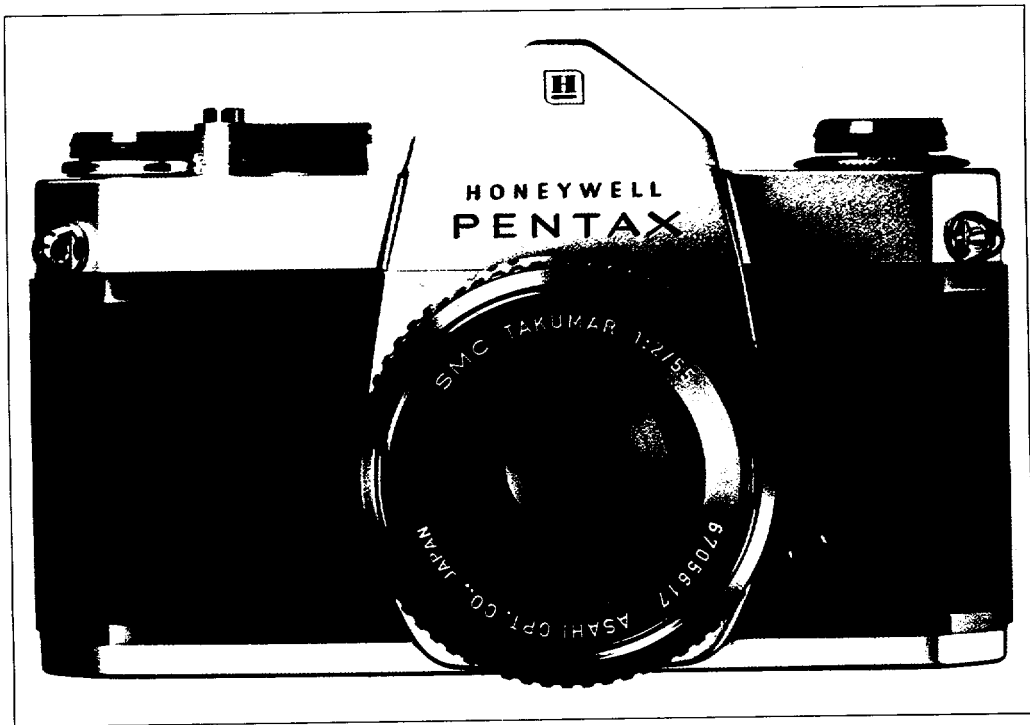

INDEX

Introduction	1
Nomenclature	2
Specifications	4
Basic operating instructions	6
Mercury battery	10
Film loading and winding	12
Film type reminder dial	14
Setting ASA film speed	15
Compose and focus	16
Automatic diaphragm	17
Shutter	18
Camera holding	19
Film unloading	20
Flash synchronization	21
Depth-of-field guide	22
Depth-of-field table: 55mm lens	23
Range of light measurement	24
Infra-red photography	26
Multiple exposure	27
Special cautions	28
Guide book	30
Warranty policy	32

HONEYWELL PENTAX SP 1000

This is the Pentax SP 1000 — proudly taking its place in the world famous Pentax family, whose name has become synonymous with design innovations and precision craftsmanship in 35mm single-lens-reflex cameras.

When the Pentax Spotmatic was first introduced at the 1960 Photokina, the world's largest photographic fair, in Cologne, Germany, it attracted the instant attention of photographers and photographic engineers alike. Though not available for purchase at the time, the Spotmatic immediately became the model with the advanced designs and innovative features that were later incorporated into many fine cameras — both Pentax and other makes.

Prior to the Spotmatic's appearance at the Photokina, the perfectionist engineers and technicians at Pentax had spent literally years developing it. And even after it had been introduced, four more years of painstaking research and experimentation were needed before the camera was completely ready. Finally, in late 1964, the Pentax Spotmatic reached the eager hands of professional and serious amateur photographers around the world.

Like that early Spotmatic, your Pentax SP 1000 is a computer camera. Its unique exposure meter — built into the camera — utilizes two highly sensitive Cadmium Sulphide sensors to accurately measure the light intensity as seen through the camera lens. By measuring the light coming through the lens (off the subject) and matching

the meter needle as seen through the viewfinder, you are assured of properly exposed pictures even under the most impossible lighting conditions. Your Pentax SP 1000 will give correctly exposed pictures with both special lenses and filters affixed to normal lenses. In addition, the SP 1000 gives you the super-fast shutter speed of a thousandth of a second. Plus complete compatibility with the entire line of SMC Takumar lenses for the clearest, sharpest pictures possible.

Your SP 1000 may also be set manually, the same as any other high-quality 35mm camera, if special lighting or selective focus effects are desired. Just leave the exposure meter switch in the "OFF" position and select the correct f/stop and speed settings for the desired effect.

Despite the incorporation of many highly advanced features and the many internal improvements that have been developed over the years, the SP 1000 retains the traditional design and simple elegance associated with earlier Pentax models. Like every member of the Pentax family, the SP 1000 has a 42mm threaded lens mount that accepts any of the fine Takumar lenses — from the fish-eye 17mm to the super-telephoto 1000mm — giving a complete line of optics that will satisfy the demands of even the most critical professional. Moreover, the list of fine accessories is always growing — to meet your future photographic needs.

NOMENCLATURE

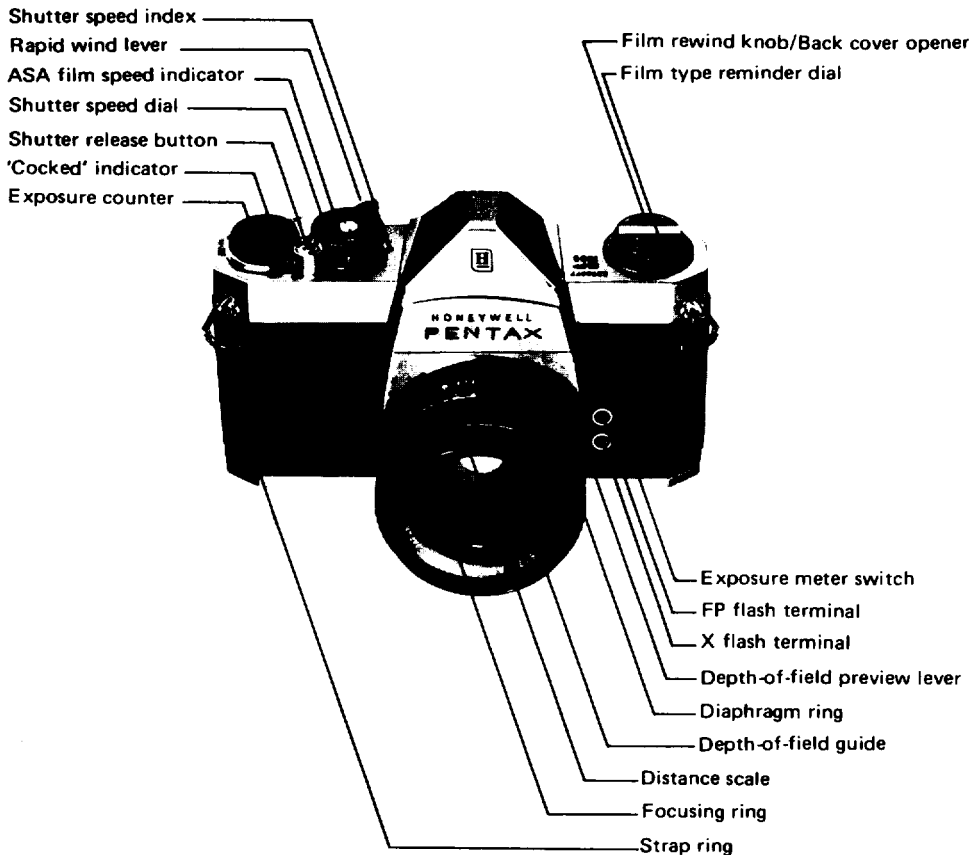

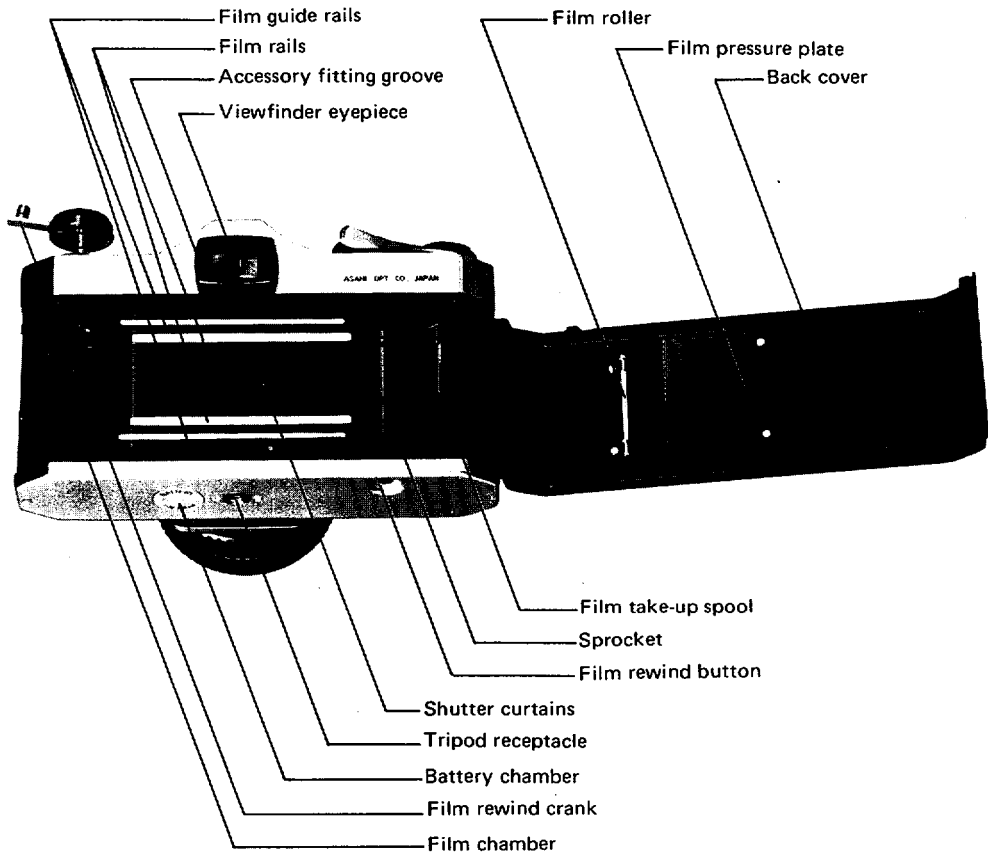

SPECIFICATIONS

Type	35mm single-lens reflex with built-in light meter.
Film and Picture Size	35mm film (20 or 36 exposures). 24mm x 36mm.
Standard Lens	SMC Takumar 55mm f/2 with fully automatic diaphragm. Filters and lenshood size: 49mm. Equipped with depth-of-field preview lever which affords visual check of depth of field. Distance scale: 45cm (18") to infinity.
Shutter	Focal plane shutter, with single non-rotating dial. Speeds: B, 1—1/1000 sec. Film speed (ASA) setting dial and window on shutter speed dial. Shutter curtains of special rubberized silk.
Warning Signal	The index of shutter speeds turns to red when the shutter and film speed settings are off the meter's measurability range.
Finder	Pentaprism finder with microprism Fresnel lens for instant focusing; approximately life size magnification with 55mm lens.
Focusing	Turn the distance scale ring until the subject image on the ground glass comes into focus.
Reflex Mirror	Instant return type with special shock absorbers for minimum vibrations.
Film Advance	Ratchet-type rapid wind lever (for film advance and shutter cocking). 10° pre-advancing and 160° advancing angle.

"Cocked" Indicator	A red disk appears in a small window alongside the shutter release button when the shutter is cocked, and blacks out when it is released.
Film Exposure Counter	Automatic re-set type.
Lens Mount	42mm threaded lens mount.
Flash Synchronization	Equipped with FP and X flash terminals. Electronic flash synchronization at 1/60 sec.
Exposure Meter	Built-in meter measures the brightness of the ground glass, and couples directly to shutter and film speed settings. Film speed (ASA) setting ranges from 20 to 1600 (LV1-18 for ASA-100 film with standard lens). Meter is powered with a mercury battery.
Film Rewind	Rapid rewind crank for speedy film take-up. Film rewind button on bottom of camera body rotates while film is being rewind.
Loaded Film Indicator	Loaded film reminder dial underneath film rewind knob is marked "PANCHRO" (black-and-white), "COLOR" and "EMPTY".
Dimension	Width 143mm (5.6") x height 92mm (3.6") x thickness 88mm (3.4").
Weight	820 grams (1 lb. 13 oz.) with standard lens. Body alone: 610 grams (1 lb. 6 oz.).

BASIC OPERATING INSTRUCTIONS

A mercury battery for the light meter is packed separately. Be sure to insert it into the battery chamber before operating the camera. For insertion instructions, refer to page 10.

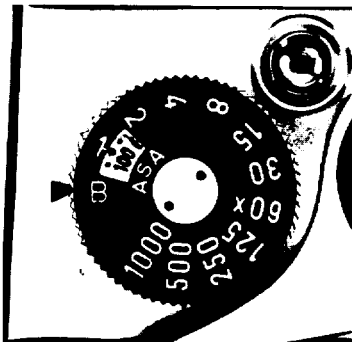

1. SET FILM SPEED

Lift the outer ring of the shutter speed dial, turn it around and set the same number as the ASA number of the loaded film to the small red index which appears alongside the figure 1. Then cock the rapid wind lever.

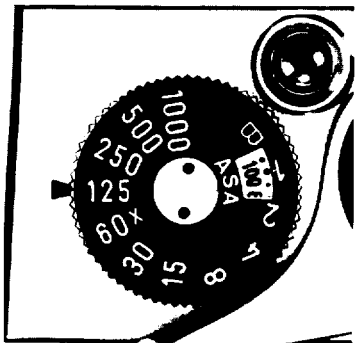

2. SET SHUTTER SPEED

Turn the shutter speed dial and set the speed you wish to use to the index. When outdoors, set the speed at 1/125 sec. or faster, depending upon the lighting. When indoors, set it at 1/30, or in its neighborhood. Change the shutter speed later, when necessary. (Refer to the instruction 5, page 8.)

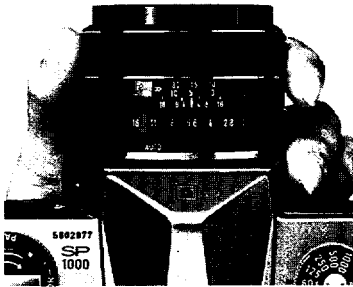

3. COMPOSE AND FOCUS

While viewing through the viewfinder, turn the focusing ring with your thumb and index finger until you get the sharpest image of your subject at the microprism center of the finder.

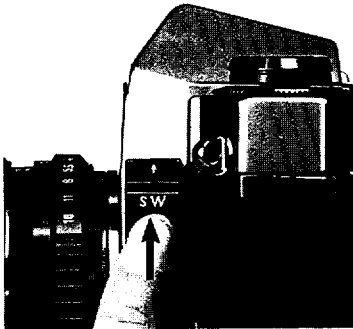

4. TURN ON LIGHT METER SWITCH

Push up the meter switch with your thumb. Through the viewfinder, you will observe the movement of the meter's needle on the right side of the ground glass. Be sure to turn off the meter switch when not actually taking readings.

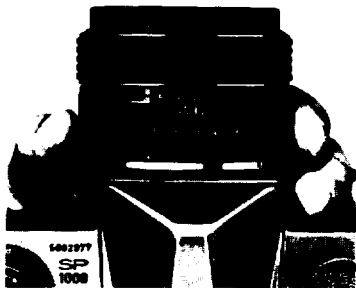

5. ROTATE DIAPHRAGM RING

The needle moves up and down with the turn of the diaphragm ring. When the needle rests at the center, you will get correct exposure. If the needle does not come to the center no matter how far you turn the diaphragm ring, change the shutter speed. When the needle is off center and close to the (+) mark, you will get over-exposure: change the shutter speed to a faster setting. If the needle is closer to the (-) mark, you will get under-exposure: change the shutter speed to a slower setting.

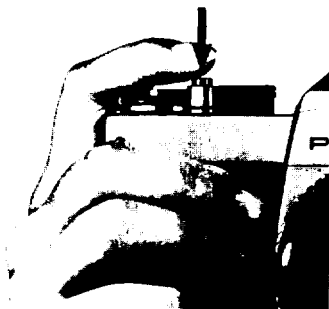

6. RELEASE SHUTTER

Hold your camera firmly and trip the shutter. When the shutter is released, the meter switch will automatically turn off, and the needle will remain fixed off and underneath the center. Cock the rapid wind lever for the next picture. (When taking a series of pictures under the same lighting conditions, it is not necessary to repeat instructions 4 and 5.)



MERCURY BATTERY

How to insert it

Open the battery housing cover on the bottom cover plate with a coin. Insert the battery with (+) side toward the top of the camera. For replacement, use Mallory PX-400 or RM-400-R or equivalent.

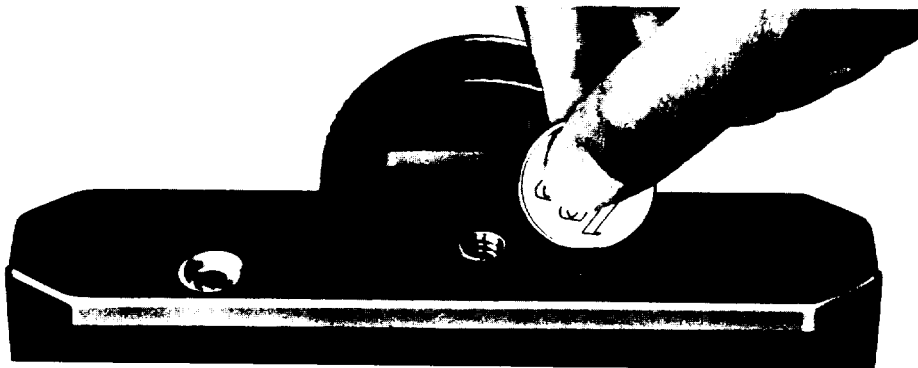

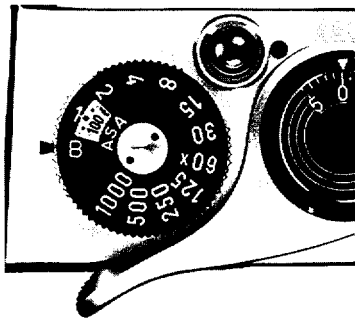

How to check it

1. Set the shutter speed dial to B (bulb) position.
2. Turn the ASA dial to ASA 100.
3. Push the meter switch to "on" position.

Look at the meter's needle through the viewfinder. If the needle rapidly drops, the meter battery has sufficient capacity; if it does not, replace the mercury battery.

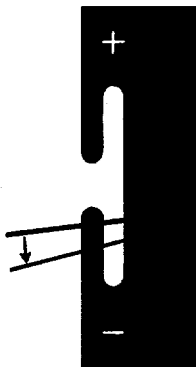

CAUTION:

The mercury battery is like a phonograph record. It can be damaged by skin acids. Handle by the edges with a dry cloth only. Be sure the battery is cleaned with the cloth before insertion into the camera. The battery is not rechargeable. Do not throw a dead battery into fire, as it may explode. Also, keep it beyond the reach of small children.

FILM LOADING AND WINDING

Avoid direct light when loading your film.

1. Open the back by pulling out the rewind knob until the back cover snaps open.

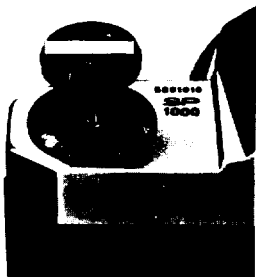

2. Place the film cassette properly into the cassette chamber, and push down the rewind knob. Insert the film leader into the slot of the take-up spool.

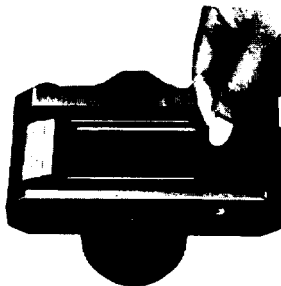

3. Advance the film by alternately turning the rapid wind lever and depressing the shutter button until both sprockets engage the film perforations properly. Close the back by pressing it firmly.



4. Cock the rapid wind lever, and confirm that the film rewind knob automatically turns counter-clockwise, indicating that the film is properly loaded and is moving from cassette to take-up spool. Trip the shutter.

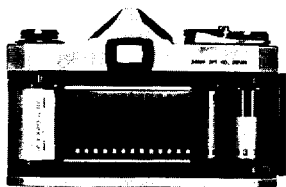

5. The first portions of the film cannot be used for picture taking as they have already been exposed to light. Generally, two or three blank exposures should be made before taking your first picture. Therefore, advance the film until the exposure counter turns to "1", indicating that the first picture is ready to be taken.

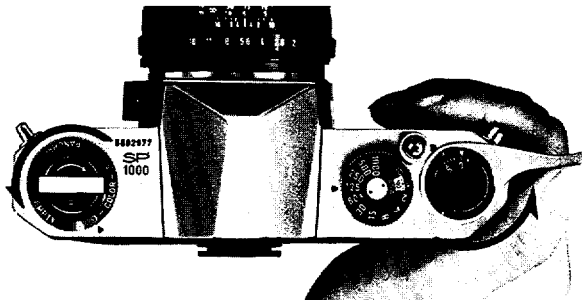

FILM TYPE REMINDER DIAL

Use the film type reminder dial to show what type of film is in your camera. Simply turn the dial so that the type of film in the camera is opposite the ▲ mark. To check whether the camera is loaded, turn the film rewind knob clockwise. If it turns freely, the camera is not loaded.

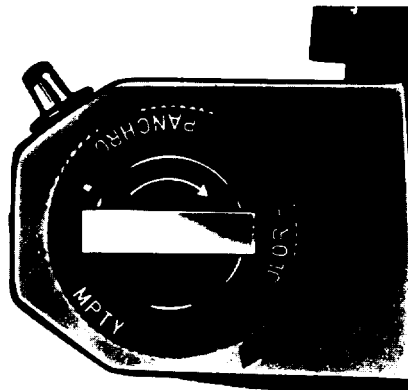

SETTING ASA FILM SPEED

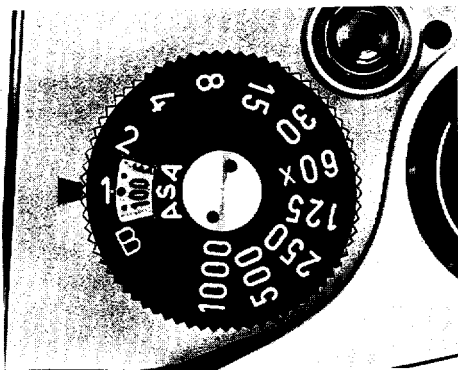

The ASA film speed rating of all 35mm films is given in the data sheet packed with each roll of film. The higher the ASA number, the more sensitive the film. Lift the outer ring of the shutter speed dial and rotate it until the ASA number of your film is opposite the orange dot alongside the figure 1.

Be sure to set your film speed on the shutter speed dial because the dial is connected to the exposure meter system.

ASA	1250	1000	640	500	320	250	160	125	80	50	40	25
	1600	800	400	200	100	64	32	20				
DIN	33	30	27	24	21	18	15					

COMPOSE AND FOCUS

While viewing through the viewfinder, turn the focusing ring until your subject comes into sharp focus.

Pentax viewfinder has a Fresnel lens with a microprism center underneath the ground glass. As you look through the finder, you will see that the Fresnel lens consists of many concentric rings which provide the brightest possible image on the ground glass.

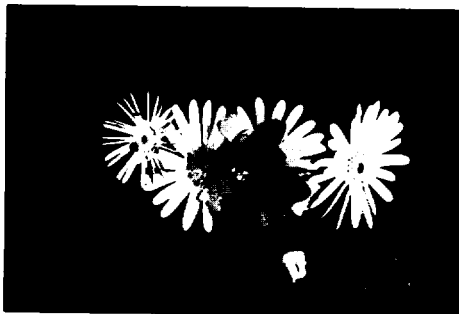

The microprism is the center portion of this diagram. When your subject is in focus, the image in the microprism will be sharp and perfectly clear. If your subject is not in focus, the microprism will break the image into many small dots, much like an engraver's screen. You can focus your subject on any portion of the ground glass.

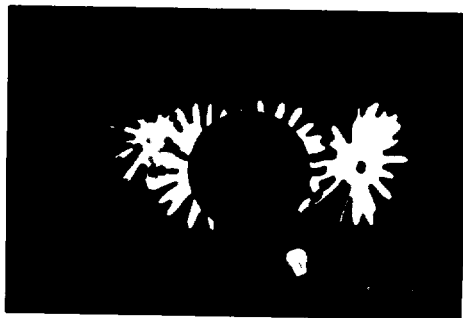

AUTOMATIC DIAPHRAGM

When the depth-of-field preview lever is in "AUTO" (automatic) position, and the exposure meter is turned to "OFF", the diaphragm is at its largest aperture at all times, except for the instant of exposure, no matter what aperture is set on the diaphragm ring. When you release the shutter, the diaphragm automatically stops down to the predetermined aperture and the shutter curtains start traveling instantly. When the exposure is completed, the diaphragm reopens to maximum aperture automatically and you are ready to compose, focus and shoot your next pictures. If you wish to visually check exact depth of field before making the exposure, move the preview lever to "MAN" (manual) position. This stops the diaphragm to the aperture selected and shows you exactly how much depth of field will appear in your picture. The preview lever may be moved back to "AUTO" position before or after making your exposure, or, if you are making pictures in bright sunlight, it may be left in manual position, which permits a constant check of depth of field.

When the meter switch is turned to the "ON" position, the lens diaphragm changes from the automatic to manual position even though the preview lever is in the "AUTO" position. When the shutter is released, the lens diaphragm will automatically return to its automatic position if the lever is set on "AUTO".

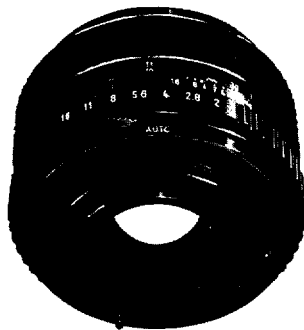

SHUTTER

Turn the shutter speed dial to the shutter speed desired. The shutter speed may be set either before or after cocking the rapid wind lever. As you cock the shutter by turning the rapid wind lever, the "cocked" indicator turns to red showing that the shutter is cocked.

The indicator window blacks out as you trip the shutter button. For use of the X setting on the shutter speed dial, refer to page 21.

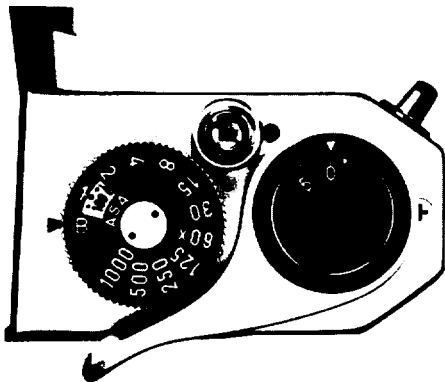

With the shutter speed dial set on B (bulb), the shutter will stay open as long as you depress the shutter button. As you release your finger from the shutter button, the shutter closes. When a long exposure is desired while using the B setting, attach a shutter release cable with a locking device to the shutter button. This will permit a "Time" exposure.

CAUTIONS:

At slow speeds — slower than 1/30 — support your camera rigidly or use a tripod to prevent movement of your camera.

To protect the shutter mechanism, trip the shutter release before putting the camera out of use for any extended period.

CAMERA HOLDING

As a general rule, your camera should be held more firmly by the left hand which does not release the shutter. If you hold your camera with the right hand — the hand which releases the shutter — it may cause camera movement. Very often, blurred pictures are due to movement of the camera.

When you focus with the camera held horizontally (Position A), hold the lens barrel as illustrated. Cradle the camera with your left hand thumb and little finger. Turn the focusing ring with your thumb and index finger. When holding the camera vertically, some people release the shutter with the thumb (Position B), while others release it with the index finder (Position C). Position C is more desirable for fast focusing and shooting. With the Pentax, whether held vertically or horizontally, you see your subject through the lens, enabling you to compose, focus and shoot with a minimum of time and effort.

Horizontal position A.

Hold the camera firmly with your left hand, and draw your arms close to your body.



Vertical position B.

Hold your camera tightly to your forehead with your left hand, and draw your right arm close to your body.



Vertical position C.

Hold your camera tightly to your forehead with your left hand, raise your right arm and draw your left arm to your body.



FILM UNLOADING

After the final picture on the roll has been taken, the rapid wind lever will not turn, indicating that the film must be rewound.



Lift the rewind crank up. Depress the film rewind release button and turn the rewind crank as indicated to rewind the film into its cassette. Rewind until the tension on the crank lessens, indicating that the leader end of the film has been released from the take-up spool.

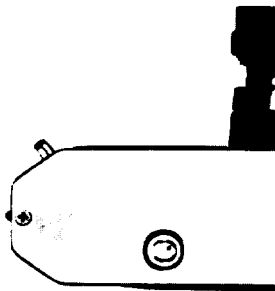

Pull out the film rewind knob (the back will open automatically), and remove the film cassette. AVOID DIRECT LIGHT WHEN LOADING OR UNLOADING THE FILM.



FLASH SYNCHRONIZATION

The Pentax SP 1000 has two terminals – FP and X. The table below shows which flash contact, which shutter speed and which flash bulb may be combined for maximum lamp efficiency. Unless these combinations are rigidly followed, there will be a failure in flash-synchronization. Note the “X” setting is exactly at the 60 marked on the speed dial. This indicates the highest shutter speed at which electronic flash units may be used.

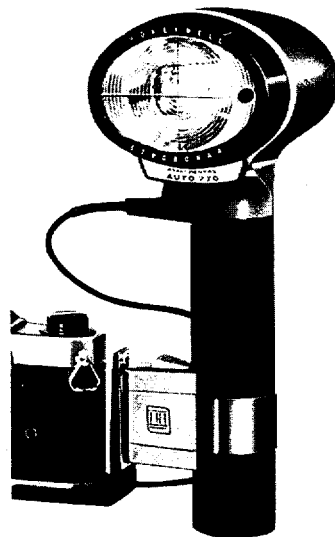

SHUTTER SPEED FLASH TERMINAL	$\frac{1}{1000}$	$\frac{1}{500}$	$\frac{1}{250}$	$\frac{1}{125}$	$\frac{1}{60}$ x	$\frac{1}{30}$	$\frac{1}{15}$	$\frac{1}{8}$	$\frac{1}{4}$	$\frac{1}{2}$	1
FP	FP Class (Screw Base)										
	FP Class (Bayonet Base)										
X							F Class				
							M Class & MF Class				
							Electronic Flash				

DEPTH-OF-FIELD GUIDE

Depth of field is the range between the nearest and farthest distances which are in focus at a given lens aperture.

If you want to know how great the depth of field is at a certain aperture, look at the depth-of-field guide. In the photograph below, the distance scale is set at 5 meters ... the lens is focused on a subject 5 meters away. The calibrations on each side of the distance index correspond to the diaphragm setting and indicate the range of in-focus distance for different lens apertures. For example, if the lens opening of $f/4$ is to be used, the range on the distance scale covered within the figure 4 on the depth-of-field guide indicates the area

in focus at that lens opening. You will note from the depth-of-field guide in the photograph that the range from approximately 4.5 to 6.5 m is in focus. Note that as the lens apertures change, the effective depth of field also changes. For the depth of fields at different apertures and distances, refer to the next page.

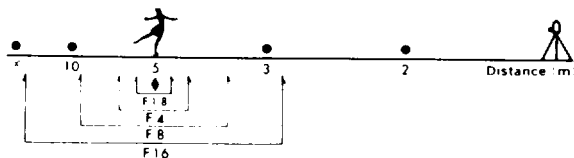
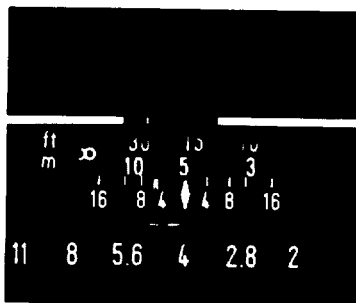

DEPTH-OF-FIELD TABLE: SMC TAKUMAR 55mm LENS

Distance scale F setting	0.45m	0.6m	1m	1.5m	2m	5m	10m	∞
F2	0.45	0.59	0.98	1.46	1.92	4.53	8.24	46.15
	0.45	0.61	1.02	1.54	2.08	5.59	12.72	~ ∞
F2.8	0.45	0.59	0.98	1.44	1.89	4.36	7.70	32.98
	0.45	0.61	1.03	1.56	2.12	5.86	14.27	~ ∞
F4	0.44	0.59	0.97	1.42	1.85	4.13	7.01	23.10
	0.46	0.61	1.04	1.59	2.17	6.33	17.48	~ ∞
F5.6	0.44	0.58	0.95	1.39	1.80	3.87	6.27	16.52
	0.46	0.62	1.05	1.63	2.25	7.09	24.97	~ ∞
F8	0.44	0.58	0.93	1.34	1.73	3.53	5.41	11.58
	0.46	0.62	1.08	1.70	2.38	8.65	70.27	~ ∞
F11	0.44	0.57	0.91	1.29	1.64	3.18	4.62	8.44
	0.47	0.63	1.11	1.79	2.57	11.93	~ ∞	~ ∞
F16	0.43	0.56	0.87	1.22	1.52	2.73	3.71	5.82
	0.47	0.65	1.17	1.96	2.95	32.75	~ ∞	~ ∞



Distance scale F setting	1'6"	2'	3'	5'	10'	15'	30'	∞
F2	1' 5.9"	1'11.8"	2'11.4"	4'10.3"	9' 4.9"	13' 8.3"	25' 1.3"	151' 4.8"
	1' 6.1"	2' 0.2"	3' 0.6"	5' 1.8"	10' 8"	16' 7.1"	37' 3.2"	~ ∞
F2.8	1' 5.9"	1'11.6"	2'11.2"	4' 9.6"	9' 2.3"	13' 2.8"	23' 7"	108' 2.3"
	1' 6.1"	2' 0.4"	3' 0.8"	5' 2.6"	10'11.5"	17' 4"	41' 3.4"	~ ∞
F4	1' 5.8"	1'11.5"	2'10.8"	4' 8.6"	8'10.7"	12' 7.1"	21' 7.2"	75' 9.5"
	1' 6.2"	2' 0.5"	3' 1.2"	5' 3.8"	11' 5.3"	18' 6.7"	49' 2.8"	~ ∞
F5.6	1' 5.6"	1'11.4"	2'10.4"	4' 7.4"	8' 6.1"	11'10.1"	19' 5.2"	54' 2.3"
	1' 6.4"	2' 0.7"	3' 1.8"	5' 5.4"	12' 1.7"	20' 6.2"	66' 3.4"	~ ∞
F8	1' 5.5"	1'11"	2' 9.8"	4' 5.6"	8'	10'10.3"	16'10.7"	37'11.9"
	1' 6.5"	2' 1"	3' 2.5"	5' 8.2"	13' 4.4"	24' 4.6"	138' 2.8"	~ ∞
F11	1' 5.4"	1'10.8"	2' 9"	4' 3.6"	7' 5.4"	9'10.1"	14' 6.2"	27' 8.2"
	1' 6.7"	2' 1.3"	3' 3.6"	5'11.8"	15' 3.7"	31'10.8"	~ ∞	~ ∞
F16	1' 5.2"	1'10.3"	2' 7.8"	4' 0.6"	6' 8.2"	8' 6.2"	11' 9.4"	19' 1"
	1' 7"	2' 2"	3' 5.5"	6' 6.8"	20' 3"	66' 9.2"	~ ∞	~ ∞

RANGE OF LIGHT MEASUREMENT

The exposure meter of the SP 1000 measures the brightness of the ground glass. Therefore, the meter should be turned on *after* you have focused your subject on the ground glass. The table on the next page shows the range of the meter's light measurement, and should not be interpreted as the camera's total range of f/stop-shutter speed combinations. As you will note from the table below, with an ASA100 film, you may use any shutter speed from 1 sec. to 1/1000 sec. in combination with any aperture that will bring the meter needle to the midpoint in the viewfinder. The total range of the aperture settings is, of course, determined by the minimum and maximum apertures of the lens being used. For example, with the 55mm f/2 lens and ASA100 film, an aperture from f/2 (the maximum aperture of this lens) to f/16 (the minimum aperture) may be used with any shutter speed from 1 sec. to 1/1000 sec. that will bring the meter needle to midpoint.

ASA \	B	1	$\frac{1}{2}$	$\frac{1}{4}$	$\frac{1}{8}$	$\frac{1}{15}$	$\frac{1}{30}$	$\frac{1}{60}$	$\frac{1}{125}$	$\frac{1}{250}$	$\frac{1}{500}$	$\frac{1}{1000}$
20	shaded	shaded	shaded	shaded	shaded	shaded	shaded	shaded	shaded			
• 25	shaded	shaded	shaded	shaded	shaded	shaded	shaded	shaded	shaded			
32	shaded	shaded	shaded	shaded	shaded	shaded	shaded	shaded	shaded			
• 40	shaded	shaded	shaded	shaded	shaded	shaded	shaded	shaded	shaded			
• 50	shaded	shaded	shaded	shaded	shaded	shaded	shaded	shaded	shaded			
64	shaded	shaded	shaded	shaded	shaded	shaded	shaded	shaded	shaded			
• 80	shaded	shaded	shaded	shaded	shaded	shaded	shaded	shaded	shaded			
100	shaded	shaded	shaded	shaded	shaded	shaded	shaded	shaded	shaded			
• 125	shaded	shaded	shaded	shaded	shaded	shaded	shaded	shaded	shaded			
• 160	shaded	shaded	shaded	shaded	shaded	shaded	shaded	shaded	shaded			
200	shaded	shaded	shaded	shaded	shaded	shaded	shaded	shaded	shaded			
• 250	shaded	shaded	shaded	shaded	shaded	shaded	shaded	shaded	shaded			
• 320	shaded	shaded	shaded	shaded	shaded	shaded	shaded	shaded	shaded			
400	shaded	shaded	shaded	shaded	shaded	shaded	shaded	shaded	shaded			
• 500	shaded	shaded	shaded	shaded	shaded	shaded	shaded	shaded	shaded			
• 640	shaded	shaded	shaded	shaded	shaded	shaded	shaded	shaded	shaded			
800	shaded	shaded	shaded	shaded	shaded	shaded	shaded	shaded	shaded			
• 1000	shaded	shaded	shaded	shaded	shaded	shaded	shaded	shaded	shaded			
• 1250	shaded	shaded	shaded	shaded	shaded	shaded	shaded	shaded	shaded			
1600	shaded	shaded	shaded	shaded	shaded	shaded	shaded	shaded	shaded			

The area A indicates the reading range of the meter. The area B indicates that although the shutter speed index is black and the meter needle moves, the meter is NOT operating properly.

When the meter needle is centered with the shutter speed dial set at B using ASA 20~50 films, this indicates that the exact shutter speed required is 2 seconds. Please expose your picture for 2 seconds.

INFRA-RED PHOTOGRAPHY

If you intend to take infra-red photographs, remember to use the infra-red index marked with an orange line or a small "R" on the depth-of-field guide.

First, focus your lens on your subject. Determine the lens-to-subject distance

from the distance scale. Then match your lens-to-subject distance to the infra-red index by turning the distance scale accordingly. For instance, if your subject is in focus at infinity, turn the distance ring and move the infinity (∞) mark to the index.

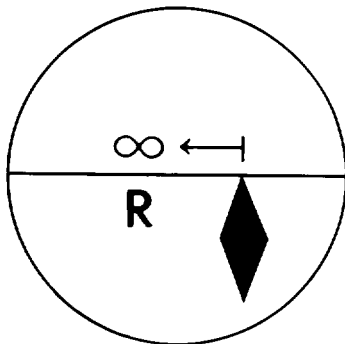
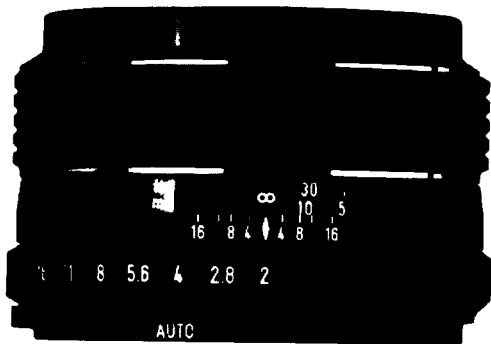

MULTIPLE EXPOSURE

For deliberate multiple exposure, make the first exposure in the normal way. Then tighten the film by turning the rewind knob ①, and keep hold of the rewind knob ①. Depress the film rewind button ② and cock the rapid wind lever. This cocks the shutter without advancing

the film. Finally, release the shutter to make the second exposure. Then make one blank exposure, before taking the next picture, to avoid overlapping. Naturally the indication of the exposure counter is not exact in this case.

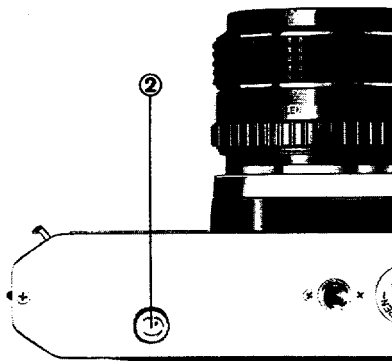
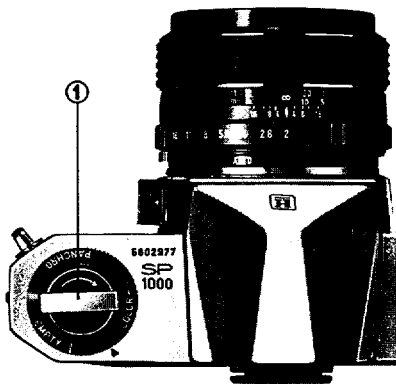

SPECIAL CAUTIONS

1

Takumar lenses and Pentax accessories are engineered and meticulously produced for Pentax use. Lenses and accessories from other manufacturers are not produced for Pentax specifications and may cause problems or difficulties with your Pentax. We cannot assume any liability if other brands are used.



2

Always keep the meter switched off when not actually taking readings. Leaving the meter switched on will rapidly exhaust the battery. It is also necessary to keep the meter switched off when interchanging lenses. If it is switched on, the tip of the automatic diaphragm release pin of the lens will hit the pin release plate inside the camera body and it may get damaged.

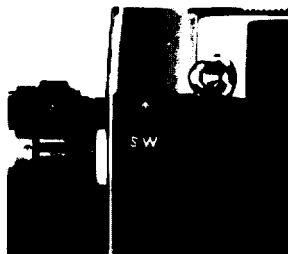

3

When the index of the shutter speeds turns to red, it indicates that the shutter and film speed settings are off the meter's measurability range. Change the shutter speed setting to a faster or slower setting. Refer to page 25.

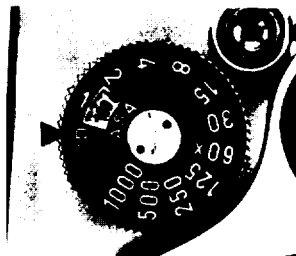

4

When the meter is switched on, the lens (any SMC Takumar lens with fully automatic diaphragm) is in its manual position even when the depth-of-field preview lever is in "AUTO" position. When the meter is switched off manually, or automatically after shutter release, the lens returns to its automatic position when the preview lever is set in "AUTO" position.

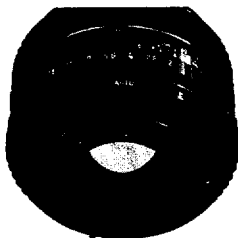

5

The integral meter of your SP 1000 correctly reads your exposures through the taking lens and through whatever accessories you use on the lens or between the lens and the camera. Thus, the exposure increase factors which apply when taking pictures with filters, close-ups, macro-and micro-hotos, do not apply to the SP 1000.

NO!

**Exposure
factor**

X 1.63
X 1.96
X 3.20
X 4.80
X 5.46

6

The length of a tripod's screw should not exceed the normal length of 4.5mm (3/16"). Do not extend it longer than this length when mounting your camera on a tripod. Forcing longer screws into the tripod receptacle will damage the mechanism.

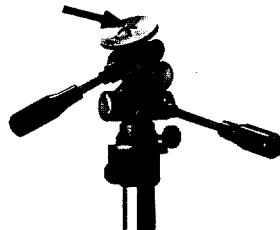

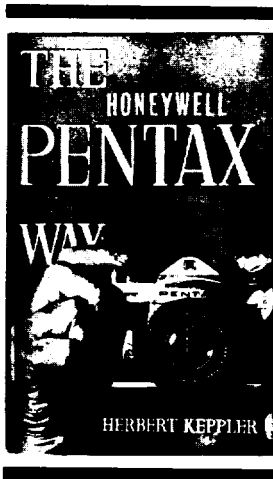

GUIDE BOOK FOR HONEYWELL PENTAX SYSTEM OF PHOTOGRAPHY

The operating manual for the Honeywell Pentax cameras is merely an instruction book for the proper care and operation of the Honeywell Pentax cameras. It does not, and can not, deal fully with every possible application of the Honeywell Pentax System of Photography because those applications are almost limitless.

The following book is therefore recommended to those amateurs who are eager to learn more about the Honeywell Pentax System of Photography and photographic technique in general. It is available in English, German, Italian and Spanish languages, and each can be obtained from your photo dealers or directly from the publishers listed on the next page.

“THE HONEYWELL PENTAX WAY” by Herbert Keppler

Herbert Keppler has been associated with the U.S. photographic magazine *Modern Photography* for over 15 years as its editor and publisher. His column devoted exclusively to single-lens reflex cameras and photography is very famous throughout the world. He is well known for his objective outlook on all things photographic and for his healthy mistrust of any theory that he has not tried out in practice. He has no interest in pushing the products of any particular manufacturer and brings to the Honeywell Pentax Way a knowledgeable, independent and unprejudiced outlook.

This comprehensive book deals mainly with the following subjects:

OPERATION AND TECHNIQUE: action, aperture, artificial light, camera care, carrying, choosing films, close-ups, copying, depth of field, developers, exposure, exposure meter, films, film speed, filters, flash, focal length, focusing, holding, lighting, loading, long-range work, monocular, multiple flash, perspective, printing, shooting, slide projection, Spotmatic operation, storing negatives, telescope, tripod, unloading, viewing.

ACCESSORIES: accessory clip, bellows unit, body cover, cable release, cassettes, close-up lenses, copying unit, exposure meters, extension tubes, focusing magnifier, Leica adapter, lens cap, lenses, microscope adapter, prescription eyepiece, right-angle finder, slide copier, SPOT exposure meter.

HONEYWELL PENTAX SUBJECTS: animals, architecture, birds, candid, cinema, fireworks, flowers, groups, lights, low light, nature, night, portraits, scenics, sports, television, theater, travel, under-water, wildlife.

FINDING DATA: close-up exposure, color temperature, depth of field, extension bellows, extension tubes, feet-meter conversion, films, film speed conversion, filters, filter equivalent, filters for color film, flash.

International editions are available from the following:

German edition:

Verlag Die Schönen Bücher
Dr. Wolf Strache,
7000 Stuttgart 1,
Postfach 1124,
WEST GERMANY

Italian edition:

Fotografare
Via Macalle 2,
Rome 00199, ITALY

Spanish edition:

Ediciones Omega, S.A.
Casanova, 220-Barcelona,
SPAIN



WARRANTY POLICY

Your new Honeywell Pentax is warranted for one year against defects in material or workmanship. This covers either the original purchaser or the gift recipient. Any defect in your will be repaired or replaced (at our option) and defective parts will be replaced without cost to you within the 12-month period, provided the camera has not been abused, altered or operated contrary to instructions. Honeywell will not be liable for damages from delay or loss of use or other indirect consequential damages.

If your camera should require service, you may send it to the most convenient factory center listed.

PENTAX INTERNATIONAL WARRANTY

If you intend taking your Pentax abroad during the warranty period, you may obtain a Honeywell Pentax international warranty card by writing to us. With your request, include your name, address, camera and lens serial numbers, dealer's name and address, and proof of date purchased.



HONEYWELL SERVICE CENTERS:

HONEYWELL INC. 5200 East Evans Avenue, Denver, Colorado 80222	(303) 756-8336
HONEYWELL INC. 24-30 Skillman Avenue, Long Island City, New York 11101	(212) 392-4300
HONEYWELL INC. 128 Newbury, Boston, Massachusetts 02116	(617) 262-2146
HONEYWELL INC. 1150 17th Street, N.W., Washington D.C. 20036	(202) 659-8980
HONEYWELL INC. 4275 Wendell Drive S.W., Atlanta, Georgia 30336	(404) 691-5900
HONEYWELL INC. No. 141 The Old Arcade, Cleveland, Ohio 44114	(216) 696-2216
HONEYWELL INC. 7120 North Lawndale Avenue, Chicago, Illinois 60645	(312) 674-9772
HONEYWELL INC. 6620 Telegraph Road, Los Angeles, California 90040	(213) 723-6611
HONEYWELL INC. 554 Mission Street, San Francisco, California 94105	(415) 398-4640
HONEYWELL INC. 45 South Ninth Street, Minneapolis, Minnesota 55402	(612) 333-7293

HONEYWELL 5200 East Evans Avenue
Denver, Colorado 80222